

Industrial High Energy Metal-Oxide Varistors

HA Series transient surge suppressors are industrial high energy metal-oxide varistors (MOVs). They are designed to provide secondary surge protection in the outdoor and service entrance environment (distribution panels) of buildings, and also in industrial applications for motor controls and power supplies used in the oil-drilling, mining, and transportation fields.

The design of the HA Series of metal oxide varistors provide rigid terminals for screw mounting. Also available in a clipped lead version for through hole board placement or to accommodate soldered leads - designation "HC".

See Ratings and Specifications table for part number and brand information.

Features

- Recognized as "Transient Voltage Surge Suppressors", UL File #E75961 to Std. 1449, Second Edition
- Recognized as "Transient Voltage Surge Suppressors", CSA File #LR91788 to Standard C22.2 No. 1-M1981
- Wide Operating Voltage Range
 $V_{M(AC)RMS}$ 130V to 750V
- Two Disc Sizes Available 32mm and 40mm
- High Energy Absorption
Capability $W_{TM} = 200J$ to 1050J
- High Peak Pulse Current
Capability $I_{TM} = 25,000A$ to 40,000A
- Rigid Terminals for Secure Mounting
- Available in Trimmed Version for Through Hole Board Mounting - Designation "HC"
- No Derating Up to 85°C Ambient

Packaging

HA SERIES

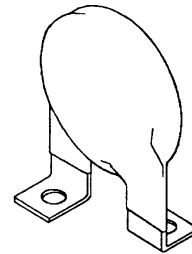

**ALSO SEE
HB34 SERIES**

HA Series

Absolute Maximum Ratings For ratings of individual members of a series, see Device Ratings and Specifications Chart

| | HA SERIES | UNITS |
|--|------------------|----------------|
| Continuous: | | |
| Steady State Applied Voltage: | | |
| AC Voltage Range ($V_{M(AC)RMS}$) | 130 to 750 | V |
| DC Voltage Range ($V_{M(DC)}$) | 175 to 970 | V |
| Transient: | | |
| Peak Pulse Current (I_{TM}) | | |
| For 8/20 μ s Current Wave (See Figure 2) | 25,000 to 40,000 | A |
| Single Pulse Energy Range | | |
| For 2ms Current Square Wave (W_{TM}) | 200 to 1050 | J |
| Operating Ambient Temperature Range (T_A) | -55 to 85 | $^{\circ}C$ |
| Storage Temperature Range (T_{STG}) | -55 to 125 | $^{\circ}C$ |
| Temperature Coefficient (αV) of Clamping Voltage (V_C) at Specified Test Current | <0.01 | %/ $^{\circ}C$ |
| Hi-Pot Encapsulation (Isolation Voltage Capability) | 2500 | V |
| (Dielectric must withstand indicated DC voltage for one minute per MIL-STD 202, Method 301) | | |
| Insulation Resistance | 1000 | $M\Omega$ |

CAUTION: Stresses above those listed in "Absolute Maximum Ratings" may cause permanent damage to the device. This is a stress only rating and operation of the device at these or any other conditions above those indicated in the operational sections of this specification is not implied.

Device Ratings and Specifications

HA Series varistors are listed under CSA File #LR91788 as a recognized component.

HA Series varistors are listed under U.L. File #E75961 as a recognized component.

| PART NUMBER AND DEVICE BRANDING | MAXIMUM RATINGS (85 $^{\circ}C$) | | | | SPECIFICATIONS (25 $^{\circ}C$) | | | | |
|--|-----------------------------------|-------------|-----------------|-----------------------------------|---|-------------|------|---|---------------------------------------|
| | CONTINUOUS | | TRANSIENT | | VARISTOR VOLTAGE AT 1mA DC TEST CURRENT | | | MAXIMUM CLAMPING VOLTAGE (V_C) AT 200A (8/20 μ s) | TYPICAL CAPACITANCE AT f = 1MHz |
| | V_{RMS} | V_{DC} | ENERGY (2ms) | PEAK CURRENT (8/20 μ s) | | | | | |
| | $V_{M(AC)}$ | $V_{M(DC)}$ | W_{TM} | I_{TM} | MIN | $V_{N(DC)}$ | MAX | V_C | C |
| (V) | (V) | ENERGY | (A) | (V) | (V) | (V) | (V) | (pF) | |
| V131HA32 | 130 | 175 | 200 | 25000 | 184 | 200 | 228 | 350 | 4700 |
| V131HA40 | 130 | 175 | 270 | 30000 | 184 | 200 | 228 | 345 | 10000 |
| V151HA32 | 150 | 200 | 220 | 25000 | 212 | 240 | 268 | 410 | 4000 |
| V151HA40 | 150 | 200 | 300 | 30000 | 212 | 240 | 268 | 405 | 8000 |
| V251HA32 | 250 | 330 | 330 | 25000 | 354 | 390 | 429 | 650 | 2500 |
| V251HA40 | 250 | 330 | 370 | 40000 | 354 | 390 | 429 | 630 | 5000 |
| V271HA32 | 275 | 369 | 360 | 25000 | 389 | 430 | 473 | 710 | 2200 |
| V271HA40 | 275 | 369 | 400 | 40000 | 389 | 430 | 473 | 690 | 4500 |
| V321HA32 | 320 | 420 | 390 | 25000 | 462 | 510 | 561 | 845 | 1900 |
| V321HA40 | 320 | 420 | 460 | 40000 | 462 | 510 | 561 | 825 | 3800 |
| V421HA32 | 420 | 560 | 400 | 25000 | 610 | 680 | 748 | 1120 | 1500 |
| V421HA40 | 420 | 560 | 600 | 40000 | 610 | 680 | 748 | 1100 | 3000 |
| V481HA32 | 480 | 640 | 450 | 25000 | 670 | 750 | 825 | 1290 | 1300 |
| V481HA40 | 480 | 640 | 650 | 40000 | 670 | 750 | 825 | 1230 | 2700 |
| V511HA32 | 510 | 675 | 500 | 25000 | 735 | 820 | 910 | 1355 | 1200 |
| V511HA40 | 510 | 675 | 700 | 40000 | 735 | 820 | 910 | 1295 | 2500 |
| V571HA32 | 575 | 730 | 550 | 25000 | 805 | 910 | 1000 | 1570 | 1100 |
| V571HA40 | 575 | 730 | 770 | 40000 | 805 | 910 | 1000 | 1480 | 2200 |
| V661HA32 | 660 | 850 | 600 | 25000 | 940 | 1050 | 1160 | 1820 | 1000 |
| V661HA40 | 660 | 850 | 900 | 40000 | 940 | 1050 | 1160 | 1720 | 2000 |
| V751HA32 | 750 | 970 | 700 | 25000 | 1080 | 1200 | 1320 | 2050 | 800 |
| V751HA40 | 750 | 970 | 1050 | 40000 | 1080 | 1200 | 1320 | 2000 | 1800 |

Power Dissipation Ratings

Should transients occur in rapid succession, the average power dissipation required is simply the energy (watt-seconds) per pulse times the number of pulses per second. The power so developed must be within the specifications shown on the Device Ratings and Specifications table for the specific device. Furthermore, the operating values need to be derated at high temperatures as shown in Figure 1. Because varistors can only dissipate a relatively small amount of average power they are, therefore, not suitable for repetitive applications that involve substantial amounts for average power dissipation.

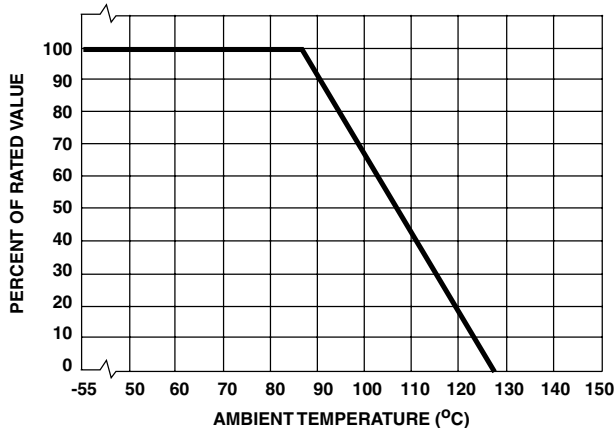
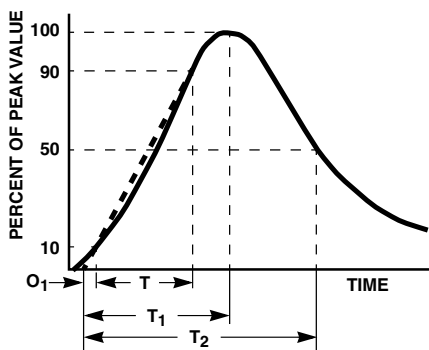

FIGURE 1. CURRENT, ENERGY AND POWER DERATING CURVE



O_1 = Virtual Origin of Wave
 T = Time From 10% to 90% of Peak
 T_1 = Virtual Front Time = $1.25 \cdot t$
 T_2 = Virtual Time to Half Value (Impulse Duration)
 Example: For an $8/20\mu s$ Current Waveform:
 $8\mu s = T_1$ = Virtual Front Time
 $20\mu s = T_2$ = Virtual Time to Half Value

FIGURE 2. PEAK PULSE CURRENT WAVEFORM

Transient V-I Characteristics Curves

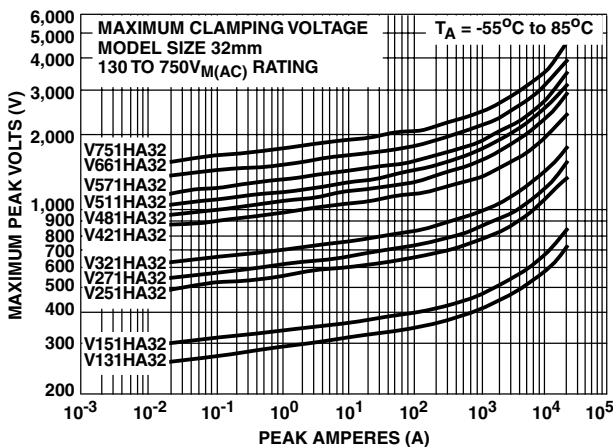

FIGURE 3. CLAMPING VOLTAGE FOR V131HA32 - V751HA32

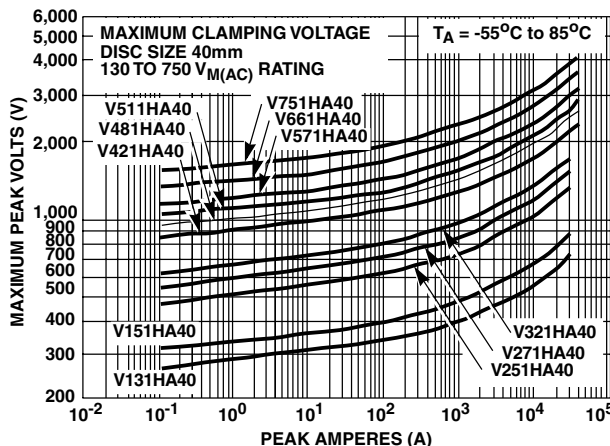

FIGURE 4. CLAMPING VOLTAGE FOR V131HA40 - V751HA40

Pulse Rating Curves

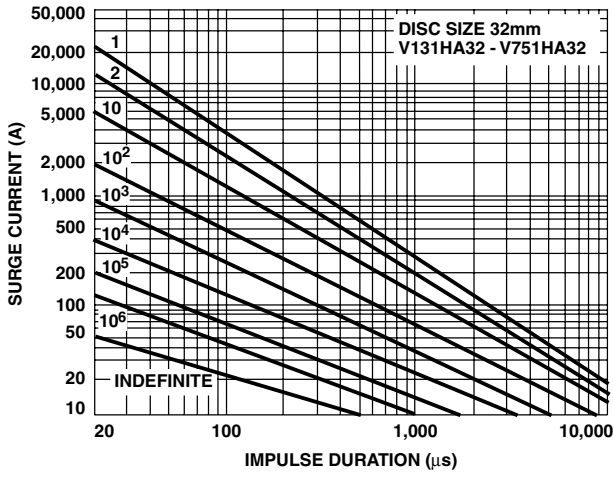

FIGURE 5. SURGE CURRENT RATING CURVES FOR V131HA32 - V751HA32

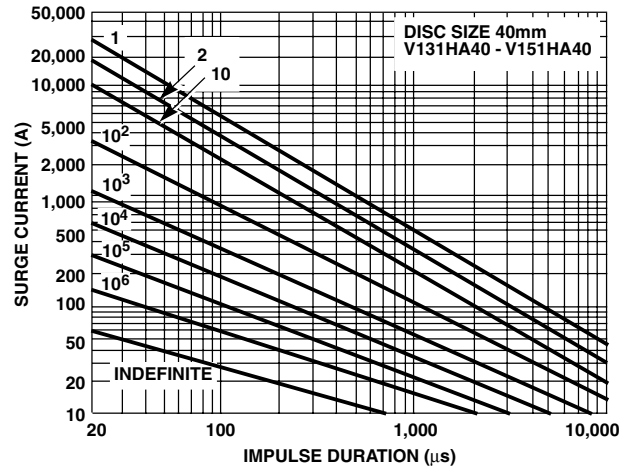

FIGURE 6. SURGE CURRENT RATING CURVES FOR V131HA40 - V151HA40

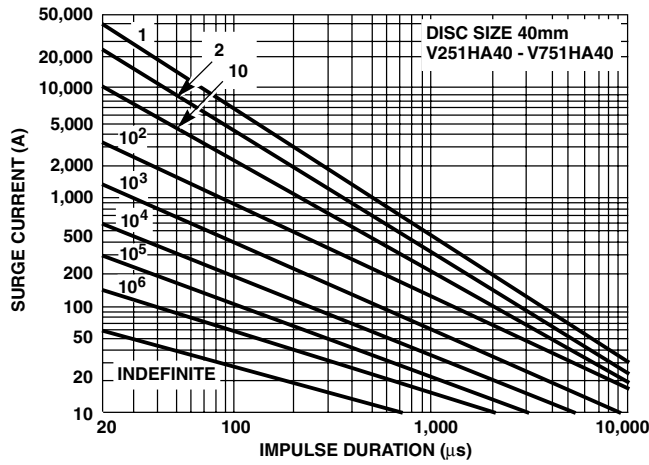

FIGURE 7. SURGE CURRENT RATING CURVES FOR V251HA40 - V751HA40

Mechanical Dimensions

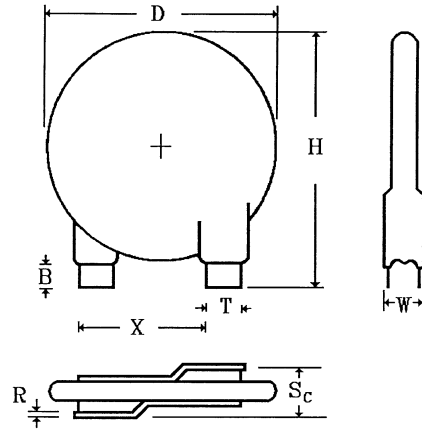
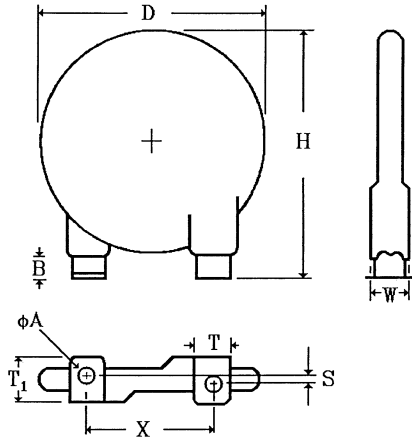

TABLE 1. HA SERIES OUTLINE SPECIFICATIONS (Dimensions in Millimeters)

| | D | H | B | X | ØA | T | T1 | S |
|------|------|-------|-----|-----|------|------|------|---|
| | MAX | MAX | MIN | NOM | MAX | NOM | NOM | OFFSET |
| HA32 | 35.5 | 52.00 | 3.0 | 25 | 4.20 | 9.30 | 10.4 | Depends on Device Voltage (See Table 2) |
| HA40 | 42.5 | 57.00 | 3.0 | 25 | 4.20 | 9.30 | 10.4 | |

TABLE 3. HC SERIES OUTLINE SPECIFICATIONS (Dimensions in Millimeters)

| | D | H | B | X | T | R | S _C |
|------|------|-------|-----|-----|------|-----|---|
| | MAX | MAX | MIN | NOM | NOM | MAX | OFFSET |
| HC32 | 35.5 | 52.00 | 5.0 | 25 | 9.30 | 1.0 | Depends on Device Voltage (See Table 4) |
| HC40 | 42.5 | 57.00 | 5.0 | 25 | 9.30 | 1.0 | |

TABLE 2. HA SERIES MAXIMUM THICKNESS AND TERMINAL OFFSETS (Dimensions in Millimeters)

| VOLTAGE | THICKNESS "W" | | DIMENSION "S" (±1mm) | |
|-------------|---------------|-------|----------------------|------|
| | HA32 | HA40 | HA32 | HA40 |
| V131 - V321 | 9.00 | 9.00 | 3.90 | 3.90 |
| V421 - V511 | 11.00 | 11.00 | 2.60 | 2.60 |
| V571 - V751 | 13.00 | 13.00 | 1.00 | 1.00 |

TABLE 4. HC SERIES MAXIMUM THICKNESS AND TERMINAL OFFSETS (Dimensions in Millimeters)

| VOLTAGE | THICKNESS "W" | | DIMENSION "S _C " (±1mm) | |
|-------------|---------------|-------|------------------------------------|-------|
| | HC32 | HC40 | HC32 | HC40 |
| V131 - V321 | 9.00 | 9.00 | 6.00 | 6.00 |
| V421 - V511 | 11.00 | 11.00 | 7.30 | 8.10 |
| V571 - V751 | 13.00 | 13.00 | 8.90 | 10.00 |

Ordering Information

