

**High Current Switching**

Analog switches are sometimes required to conduct appreciable amounts of current, either continuous, or instantaneous - such as charging or discharging a capacitor. For best reliability, it is recommended that instantaneous current be limited to less than 80mA peak and that average power over any 100 millisecond period be limited to  $\leq I^2 \times R_{ON}$  (absolute maximum derated power- quiescent power). Note that  $R_{ON}$  increases at high current levels, which is characteristic of any FET switch. Switching elements may be connected in parallel to reduce  $R_{ON}$ .

**Op Amp Switching Applications**

When analog switches are used either to select an op amp input, or to change op amp gain, minor circuit rearrangements can frequently enhance accuracy. In Figure 1,  $R_{ON}$  of the input selector switch adds to  $R_1$ , reducing gain and allowing gain to change with temperature. By switching into a non inverting amplifier (b), gain change becomes negligible. Similarly, in a gain switching circuit,  $R_{ON}$  is part of the gain determining network in (c), but has negligible effect in (d).

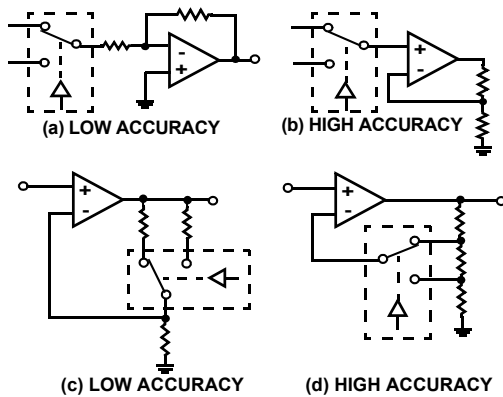
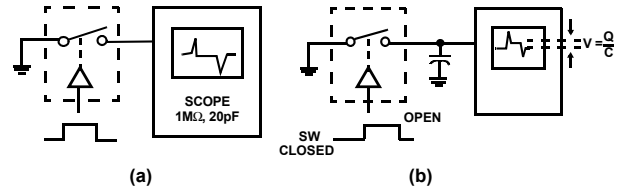

**FIGURE 1. OP AMP SWITCHING APPLICATIONS**

**Switching Spikes And Charge Injection**

Transient effects when turning a switch off or on are of concern in certain applications. Short duration spikes are generated (Figure 2 (a)) as a result of capacitive coupling between digital signals and the analog output. These have the effect of creating an acquisition time interval during which the output level is invalid even when little or no steady state level change is involved. The total net energy (charge injection) coupled to the analog circuit is of concern when switching the voltage on a capacitor, since the injected

charge will change the capacitor voltage at the instant the switch is opened (Figure 2 (b)).



**FIGURE 2. SWITCHING SPIKES AND CHARGE INJECTION**

Charge injection is measured in picocoulombs; the voltage transferred to the capacitor is computed by:

$$V = \frac{\text{Charge (pC)}}{\text{Capacitance (pF)}}$$

Both of these effects are, in general, considerably less for CMOS switches than for equivalent resistance JFET or PMOS devices, since the gate drive signals for the two switching transistors are of opposite polarity. However, complete cancellation is not possible, since the N and P channel switches do not receive gate signals quite simultaneously, and their geometries are necessarily different to achieve the desired DC resistance match.

In applications where transients create a problem, it is frequently possible to minimize the effect by cancellation in a differential circuit, similar to Figure 3.

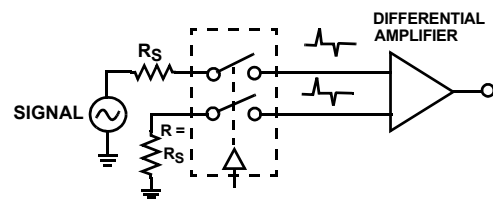

**FIGURE 3. DIFFERENTIAL CIRCUIT**

Among the analog switches, the HI-201 is the best from the transient standpoint, having turn-on spikes of about 100mV peak, 50ns width at the 50% point, and charge injection at turn-off of about 20 picocoulombs. Transients of the HI-504X series are several times higher.

## High Frequency Switching

When considering a switching element for RF or video type information, two factors must be watched: attenuation vs. frequency characteristics of an ON switch, and feedthrough (isolation) vs. frequency characteristics of the OFF switch.

Optimizing the first characteristic requires a low  $R_{ON} \times C_D$  product, and the second a low value of  $C_{DS}$  (OFF).

One approach is to use the  $30\Omega$  switch types of the HI-5040 series.

Figure 4 illustrates three circuit configurations; (a) is a simple series switch, (b) is a series-shunt configuration to reduce feedthrough, and (c) is an SPDT selector configuration with series-shunt elements. A  $1k\Omega$  load is illustrated, which might be the input impedance of a buffer amplifier; a lower load resistance would improve the response characteristics, but would create greater losses in the switch and would tend to distort high level signals.

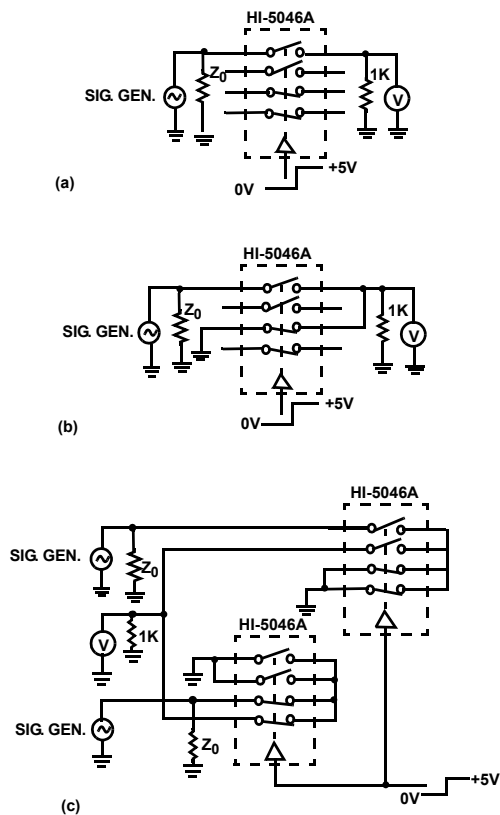

FIGURE 4. CIRCUIT CONFIGURATIONS

Figure 5 shows ON and OFF frequency response for each of the above configurations. Arbitrarily, we will define useful frequency response as the region where ON losses are less than 3dB and OFF isolation is greater than -40dB.

The simple configuration (a) has excellent ON response, but OFF isolation limits the useful range to about 1MHz (the data sheet indicates -80dB isolation at 100kHz, but this is measured with  $100\Omega$  load, which accounts for the 20dB difference).

The circuit in (b) shows a good improvement in isolation produced by the low impedance of the shunt switch. The useful range is about 10MHz, which could also be achieved in a simple SPDT 2-switch selector if source impedances are very low.

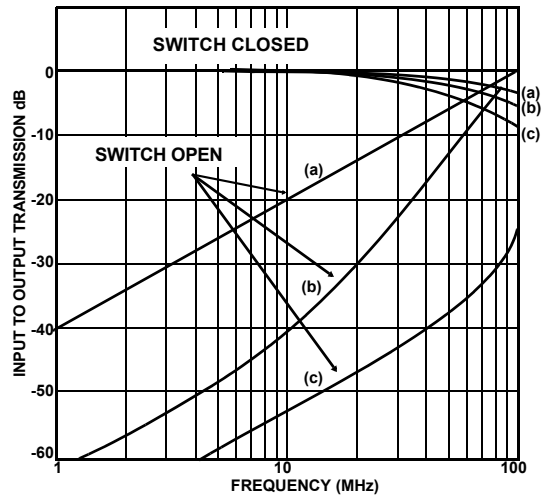
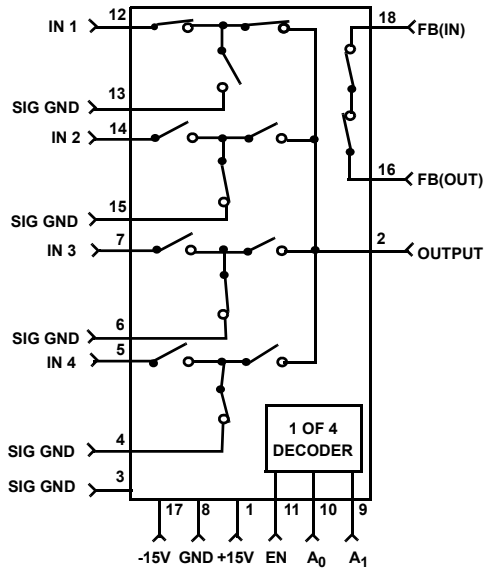

FIGURE 5. ON AND OFF FREQUENCY RESPONSES

The selector switch in (c) has excellent characteristics, both ON and OFF curves indicating 40MHz useful response. Additional switches connected to the same point would reduce the ON response because of added shunt capacitance, but this could be eliminated by feeding separate summing amplifier inputs.

For many applications, a better approach is to use the HI-524 monolithic wideband CMOS multiplexer. This device utilizes a series-shunt multiple switching network to achieve low crosstalk without sacrificing or compromising other operational parameters. As shown in Figure 6, each channel comprises three CMOS FET switch gates, with two in series and the third shunted to ground. The two series switches ensure both a high off isolation and low feed-through capacitance. The shunt grounding switch, closed automatically by the control logic when its corresponding series pair are open, shunts nonselected channels to ground, thus minimizing crosstalk. With this circuit topology, crosstalk is typically -60dB at 10MHz.

A buffer amplifier is used with the HI-524 for high frequency applications, due to its higher ON resistance, and should offer sufficient bandwidth and slew rate to avoid degradation of the anticipated signals. For video switching, the HA-5033 and HA-2542 offer good performance plus  $\pm 100mA$  output



**FIGURE 6. HI-524 MONOLITHIC WIDEBAND CMOS MULTIPLEXER**

current for driving coaxial cables. For general wideband applications, the HA-2541 offers the convenience of unity gain stability plus 90ns settling (to  $\pm 0.1\%$ ) and  $\pm 10V$  output swing. Also, the HI-524 includes a feedback resistance for use with the HA-2541. This resistance matches and tracks the channel ON resistance, to minimize offset voltage due to the buffer's bias currents.

Careful layout is, of course, important for high frequency switching applications to avoid feedthrough paths or excessive load capacitance.

All Intersil U.S. products are manufactured, assembled and tested utilizing ISO9000 quality systems. Intersil Corporation's quality certifications can be viewed at [www.intersil.com/design/quality](http://www.intersil.com/design/quality)

*Intersil products are sold by description only. Intersil Corporation reserves the right to make changes in circuit design, software and/or specifications at any time without notice. Accordingly, the reader is cautioned to verify that data sheets are current before placing orders. Information furnished by Intersil is believed to be accurate and reliable. However, no responsibility is assumed by Intersil or its subsidiaries for its use; nor for any infringements of patents or other rights of third parties which may result from its use. No license is granted by implication or otherwise under any patent or patent rights of Intersil or its subsidiaries.*

For information regarding Intersil Corporation and its products, see [www.intersil.com](http://www.intersil.com)