

CONNECTOR POSITIONS	RECEPTACLE CONNECTORS				PLUG CONNECTORS	
	RIGHT-ANGLE		VERTICAL		RIGHT-ANGLE	VERTICAL
	UNSHIELDED	SHIELDED	UNSHIELDED	SHIELDED	UNSHIELDED	
14	552738	---	552212	---	552739	552209
24	552740, 552791†	553119, 553121, 553811, 554923, 555139	552224	554501	552741	552221
36	552742, 555493	553448, 553815, 554907, 555119, 555233, 555520	552235	554145, 554400	552743	552232
50	552725, 554663, 554841, 555492	553813, 554901, 555057, 555149	552118	554216, 554217	552726	552116
64	552744	---	552246	---	552745	552243

**NOTE:** Right-Angle-Mount Plug and Receptacle Connectors are available in standard pin orientation and reverse pin orientation.  
†For IEEE 488-1975 applications.

Figure 1

**1. INTRODUCTION** (Figure 1)

This instruction sheet covers the CHAMP Right-Angle-Mount and Vertical-Mount PC Board Connectors (unshielded and shielded).

These instructions include connector description and connector mounting procedures. Read this and all referenced material thoroughly before installing any connectors.

**NOTE** *Dimensions are in millimeters [with inch equivalents in brackets]. Figures are for identification only and are not drawn to scale.*

Reasons for reissue are provided in Section 5, REVISION SUMMARY.

**2. DESCRIPTION**

Plug and receptacle connectors consist of polarized housings which are preloaded with solder-tine contacts on 2.16 mm [.085 in.] centers. They are available with 14, 24, 36, 50, and 64 contact positions that are arranged in two opposing rows.

Vertical-mount connectors feature straight contact tines with 4.29 mm [.169 in.] between rows. The connectors may be installed on 1.57–3.18 mm [.062–.125 in.] thick pc boards. Shielded connectors have 2.54 and 5.08 mm [.100 and .200 in.] tail lengths. The 2.54 mm [.100 in.] tail can only be used on 1.57 mm [.062 in.] thick pc boards.

Right-angle-mount connectors are available for standard or reverse pin orientation on the pc board, refer to Figure 3 for application pin location. The contacts feature 90° bent contact tines with 4.29 mm [.169 in.] between rows. The connectors may be installed on 1.57–3.18 mm [.062–.125 in.] thick pc boards. Shielded connectors have a 3.99 mm [.157 in.] tail length, which is not suitable for 3.18 mm [.125 in.] thick pc boards.

Shielded CHAMP Connectors afford excellent protection from Electromagnetic Interference (EMI) or electrostatic discharge to sensitive circuitry.

These connectors are intermateable with existing connectors for cable-to-pc board applications. Refer to Instruction Sheet 7564 for cable connector information. All connectors have mounting flanges for attachment to the pc board and/or mating connector. Refer to instruction sheet 408-3160 for hardware information.

**3. CONNECTOR MOUNTING PROCEDURES**

**CAUTION** BEFORE attempting to install connector on the pc board, CLOSELY inspect for deformed broken contacts.

**NOTE** Care must be used when installing these connectors; otherwise, the contact tines may be damaged. Also, correct orientation of the connector pin pattern with the pc board pattern should be checked.

The following procedures are recommended for shielded and unshielded connectors:

1. Hold connector at a slight angle to the pc board and start one row of contacts into the contact holes. See Figure 2.
2. Rotate the connector until contact tines are aligned with opposite row of holes on pc board.
3. Make sure contact tines have started entrance into the holes, then push connector straight down until the standoffs bottom on the pc board.

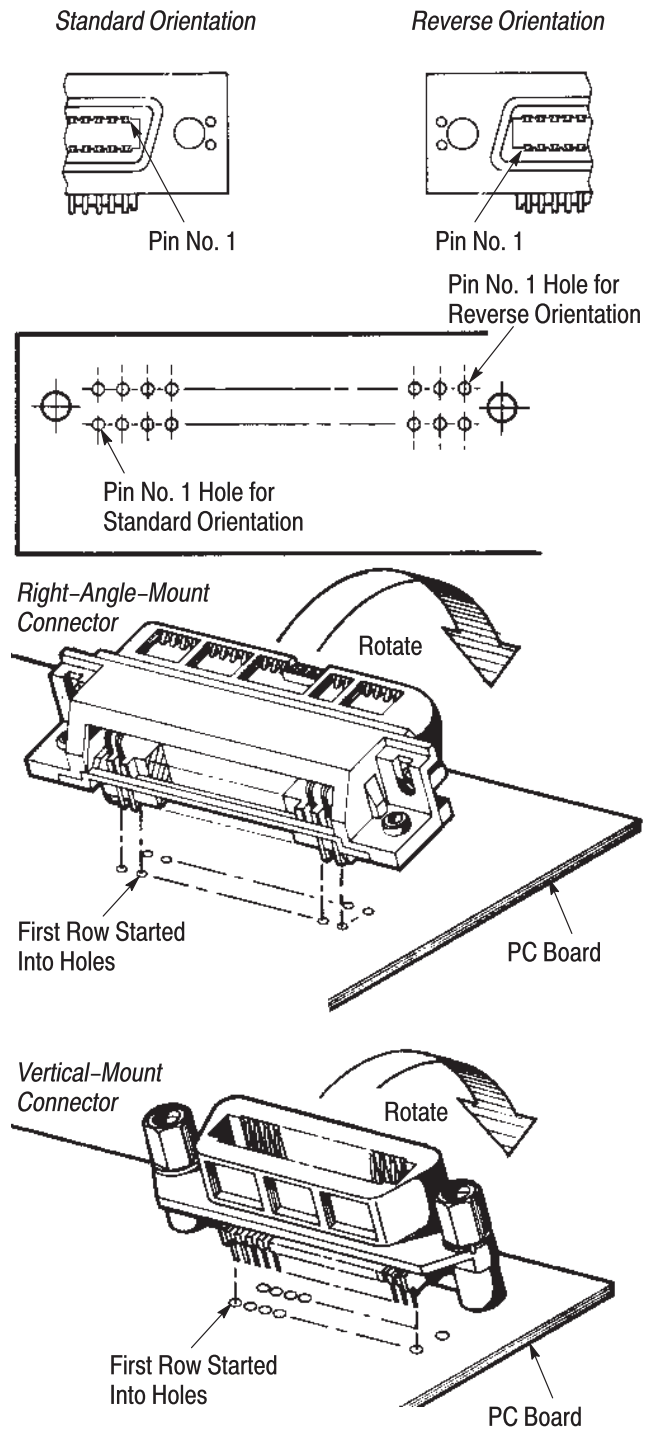

Figure 2

4. Inspect contacts to make certain none have been deformed. All contact tines MUST extend through the pc board a minimum of 0.81 mm [.032 in.] for a good fillet.
5. Secure connector to pc board with CHAMP connector approved hardware, or the appropriate hardware kit selected for mating connectors.

6. Solder contact tines to the pc board using high density wave solderable applications, or a standard reflow soldering technique.

#### 4. PANEL MOUNTING

Either the plug or receptacle right-angle-mount or vertical-mount connector may be REAR panel mounted (see Figure 3).

**NOTE**

*Panel thickness affects connector mating and hardware fastening. Consult reference documents or Tyco Electronics Engineering for application requirements.*

#### 5. REVISION SUMMARY

- Updated document to corporate requirements
- General update to format
- Deleted obsolete part numbers from table in Figure 1

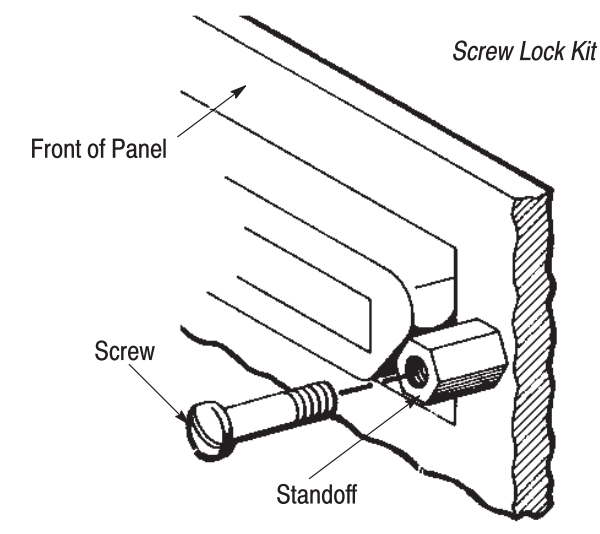

Figure 3