

S25FL Family (Serial Peripheral Interface) S25FL004A

4-Megabit CMOS 3.0 Volt Flash Memory
with 50 Mhz SPI Bus Interface



ADVANCE
INFORMATION

Notice to Readers: The Advance Information status indicates that this document contains information on one or more products under development at Spansion LLC. The information is intended to help you evaluate this product. Do not design in this product without contacting the factory. Spansion LLC reserves the right to change or discontinue work on this proposed product without notice.

Notice On Data Sheet Designations

Spansion LLC issues data sheets with Advance Information or Preliminary designations to advise readers of product information or intended specifications throughout the product life cycle, including development, qualification, initial production, and full production. In all cases, however, readers are encouraged to verify that they have the latest information before finalizing their design. The following descriptions of Spansion data sheet designations are presented here to highlight their presence and definitions.

Advance Information

The Advance Information designation indicates that Spansion LLC is developing one or more specific products, but has not committed any design to production. Information presented in a document with this designation is likely to change, and in some cases, development on the product may discontinue. Spansion LLC therefore places the following conditions upon Advance Information content:

"This document contains information on one or more products under development at Spansion LLC. The information is intended to help you evaluate this product. Do not design in this product without contacting the factory. Spansion LLC reserves the right to change or discontinue work on this proposed product without notice."

Preliminary

The Preliminary designation indicates that the product development has progressed such that a commitment to production has taken place. This designation covers several aspects of the product life cycle, including product qualification, initial production, and the subsequent phases in the manufacturing process that occur before full production is achieved. Changes to the technical specifications presented in a Preliminary document should be expected while keeping these aspects of production under consideration. Spansion places the following conditions upon Preliminary content:

"This document states the current technical specifications regarding the Spansion product(s) described herein. The Preliminary status of this document indicates that product qualification has been completed, and that initial production has begun. Due to the phases of the manufacturing process that require maintaining efficiency and quality, this document may be revised by subsequent versions or modifications due to changes in technical specifications."

Combination

Some data sheets will contain a combination of products with different designations (Advance Information, Preliminary, or Full Production). This type of document will distinguish these products and their designations wherever necessary, typically on the first page, the ordering information page, and pages with DC Characteristics table and AC Erase and Program table (in the table notes). The disclaimer on the first page refers the reader to the notice on this page.

Full Production (No Designation on Document)

When a product has been in production for a period of time such that no changes or only nominal changes are expected, the Preliminary designation is removed from the data sheet. Nominal changes may include those affecting the number of ordering part numbers available, such as the addition or deletion of a speed option, temperature range, package type, or V_{IO} range. Changes may also include those needed to clarify a description or to correct a typographical error or incorrect specification. Spansion LLC applies the following conditions to documents in this category:

"This document states the current technical specifications regarding the Spansion product(s) described herein. Spansion LLC deems the products to have been in sufficient production volume such that subsequent versions of this document are not expected to change. However, typographical or specification corrections, or modifications to the valid combinations offered may occur."

Questions regarding these document designations may be directed to your local AMD or Fujitsu sales office.

S25FL Family (Serial Peripheral Interface) S25FL004A



4-Megabit CMOS 3.0 Volt Flash Memory
with 50 Mhz SPI Bus Interface

Data Sheet

ADVANCE
INFORMATION

Distinctive Characteristics

Architectural Advantages

- **Single power supply operation**
 - Full voltage range: 2.7 to 3.6 V read and program operations
- **Memory Architecture**
 - Eight sectors with 512 Kb each
- **Program**
 - Page Program (up to 256 bytes) in 1.5 ms (typical)
 - Program cycles are on a page by page basis
- **Erase**
 - 1.5 s typical sector erase time
 - 12 s typical bulk erase time
- **Cycling Endurance**
 - 100,000 cycles per sector typical
- **Data Retention**
 - 20 years typical
- **Device ID**
 - JEDEC standard two-byte electronic signature
 - RES instruction one-byte electronic signature for backward compatibility
- **Process Technology**
 - Manufactured on 0.20 μ m MirrorBit™ process technology

Package Option

- Industry Standard Pinouts
- 8-pin SO package (208 mils)
- 8-Contact USON Package (5 x 6 mm), Pb-Free

Performance Characteristics

- **Speed**
 - 50 MHz clock rate (maximum)
- **Power Saving Standby Mode**
 - Standby Mode 50 μ A (max)
 - Deep Power Down Mode 1 μ A (typical)

Memory Protection Features

- **Memory Protection**
 - W# pin works in conjunction with Status Register Bits to protect specified memory areas
 - Status Register Block Protection bits (BP2, BP1, BP0) in status register configure parts of memory as read-only

Software Features

- **SPI Bus Compatible Serial Interface**

General Description

The S25FL004A device is a 3.0 Volt (2.7 V to 3.6 V) single power supply Flash memory device. S25FL004A consists of eight sectors, each with 512 Kb memory.

Data appears on SI input pin when inputting data into the memory and on the SO output pin when outputting data from the memory. The devices are designed to be programmed in-system with the standard system 3.0 Volt V_{CC} supply.

The memory can be programmed 1 to 256 bytes at a time, using the Page Program instruction.

The memory supports Sector Erase and Bulk Erase instructions.

Each device requires only a 3.0 Volt power supply (2.7 V to 3.6 V) for both read and write functions. Internally generated and regulated voltages are provided for the program operations. This device does not require V_{PP} supply.

Table of Contents

Block Diagram	4	Table 6. Read Identification (RDID) Data-Out Sequence	22
Connection Diagrams	5	Page Program (PP)	22
Logic Symbol	6	Figure 12. Page Program (PP) Instruction Sequence	23
Ordering Information	7	Sector Erase (SE)	23
Table 1. S25FL Valid Combinations Table	7	Figure 13. Sector Erase (SE) Instruction Sequence	24
Signal Description	8	Bulk Erase (BE)	24
SPI Modes	8	Figure 14. Bulk Erase (BE) Instruction Sequence	25
Figure 1. Bus Master and Memory Devices on the SPI Bus	9	Deep Power Down (DP)	25
Figure 2. SPI Modes Supported	9	Figure 15. Deep Power Down (DP) Instruction Sequence	26
Operating Features	10	Release from Deep Power Down (RES)	26
Page Programming	10	Figure 16. Release from Deep Power Down Instruction Sequence	27
Sector Erase, or Bulk Erase	10	Release from Deep Power Down and Read Electronic Signature (RES)	27
Polling During a Write, Program, or Erase Cycle	10	Figure 17. Release from Deep Power Down and Read Electronic Signature (RES) Instruction Sequence	28
Status Register	10	Power-up and Power-down	28
Protection Modes	11	Figure 18. Power-Up Timing	29
Table 2. Protected Area Sizes (S25FL004A)	11	Table 7. Power-Up Timing	29
Hold Condition Modes	11	Initial Delivery State	29
Figure 3. Hold Condition Activation	12	Maximum Rating	29
Memory Organization	13	Absolute Maximum Ratings	29
Table 3. Sector Address Table – S25FL004A	13	Operating Ranges	29
Instructions	14	DC Characteristics	30
Table 4. Instruction Set	15	Table 8. DC Characteristics	30
Write Enable (WREN)	15	Test Conditions	31
Figure 4. Write Enable (WREN) Instruction Sequence	15	Figure 19. AC Measurements I/O Waveform	31
Write Disable (WRDI)	16	Table 9. Test Specifications	31
Figure 5. Write Disable (WRDI) Instruction Sequence	16	AC Characteristics	32
Read Status Register (RDSR)	17	Table 10. AC Characteristics	32
Figure 6. Read Status Register (RDSR) Instruction Sequence	17	Figure 20. SPI Mode 0 (0,0) Input Timing	33
Figure 7. Status Register Format	17	Figure 21. SPI Mode 0 (0,0) Output Timing	33
Write Status Register (WRSR)	18	Figure 22. HOLD# Timing	34
Figure 8. Write Status Register (WRSR) Instruction Sequence	18	Figure 23. Write Protect Setup and Hold Timing during WRSR when SRWD=1	34
Read Data Bytes (READ)	19	Physical Dimensions	35
Figure 9. Read Data Bytes (READ) Instruction Sequence	20	S08 wide—8-pin Plastic Small Outline 208 mils Body Width Package	35
Read Data Bytes at Higher Speed (FAST_READ)	20	USON 8L (5x6mm) No-Lead Package	36
Figure 10. Read Data Bytes at Higher Speed (FAST_READ) Instruction Sequence	20	Revision Summary	37
Read Identification (RDID)	21		
Figure 11. Read Identification (RDID) Instruction Sequence and Data-Out Sequence	21		

Block Diagram

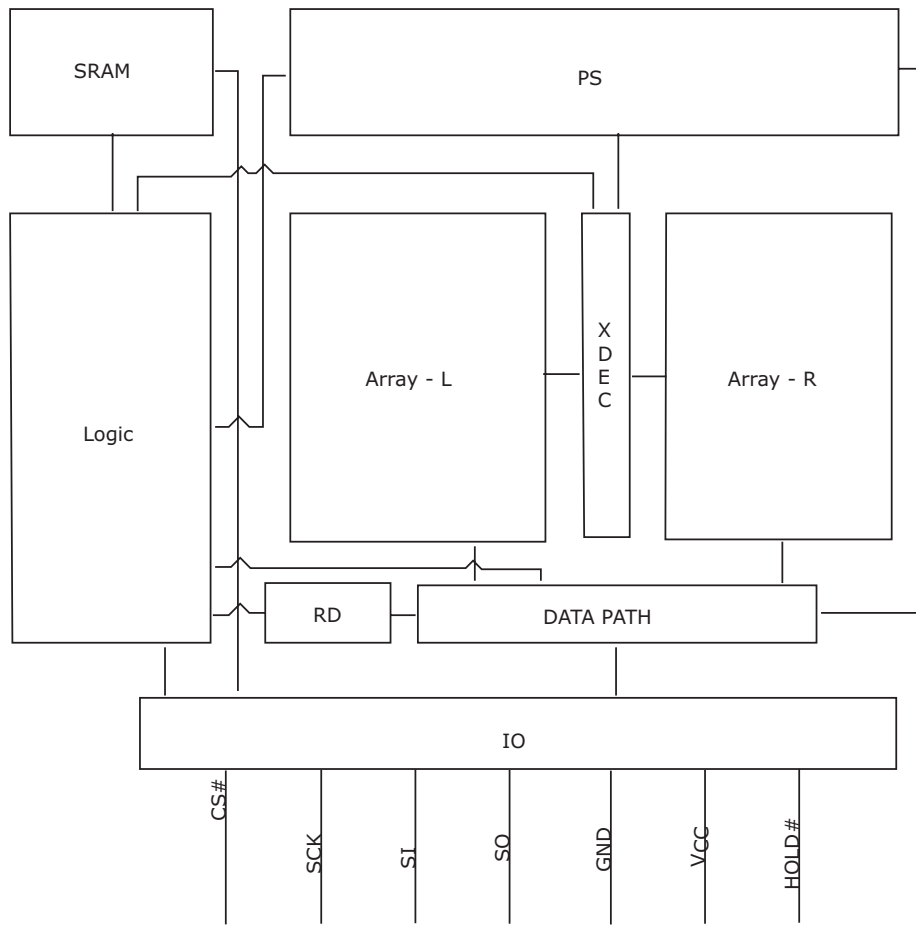

Connection Diagrams

8-pin Plastic Small Outline Package (SO)

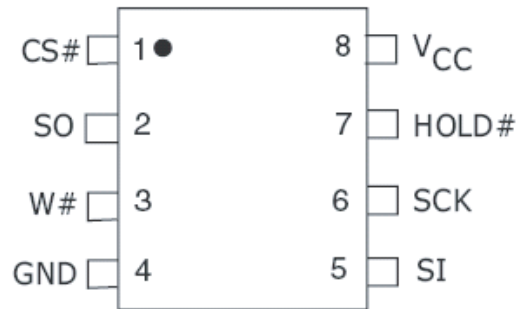

8L USON (5x6mm²) Package

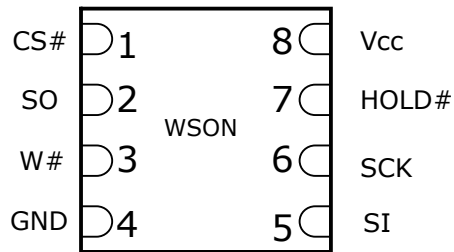

Input/Output Descriptions

SCK	=	Serial Clock Input
SI	=	Serial Data Input
SO	=	Serial Data Output
CS#	=	Chip Select Input
W#	=	Write Protect Input
HOLD#	=	Hold Input
V _{CC}	=	Supply Voltage Input
GND	=	Ground Input

Logic Symbol

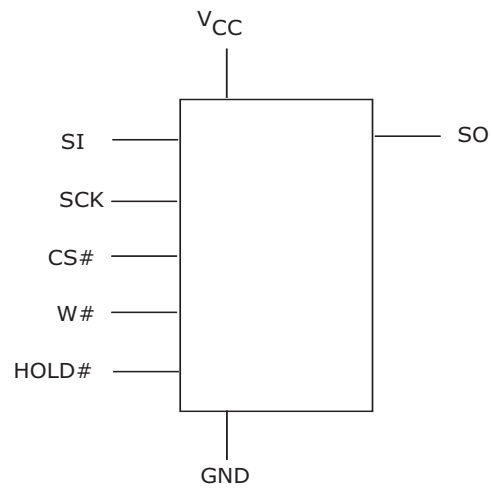

Ordering Information

The ordering part number is formed by the following valid combinations:

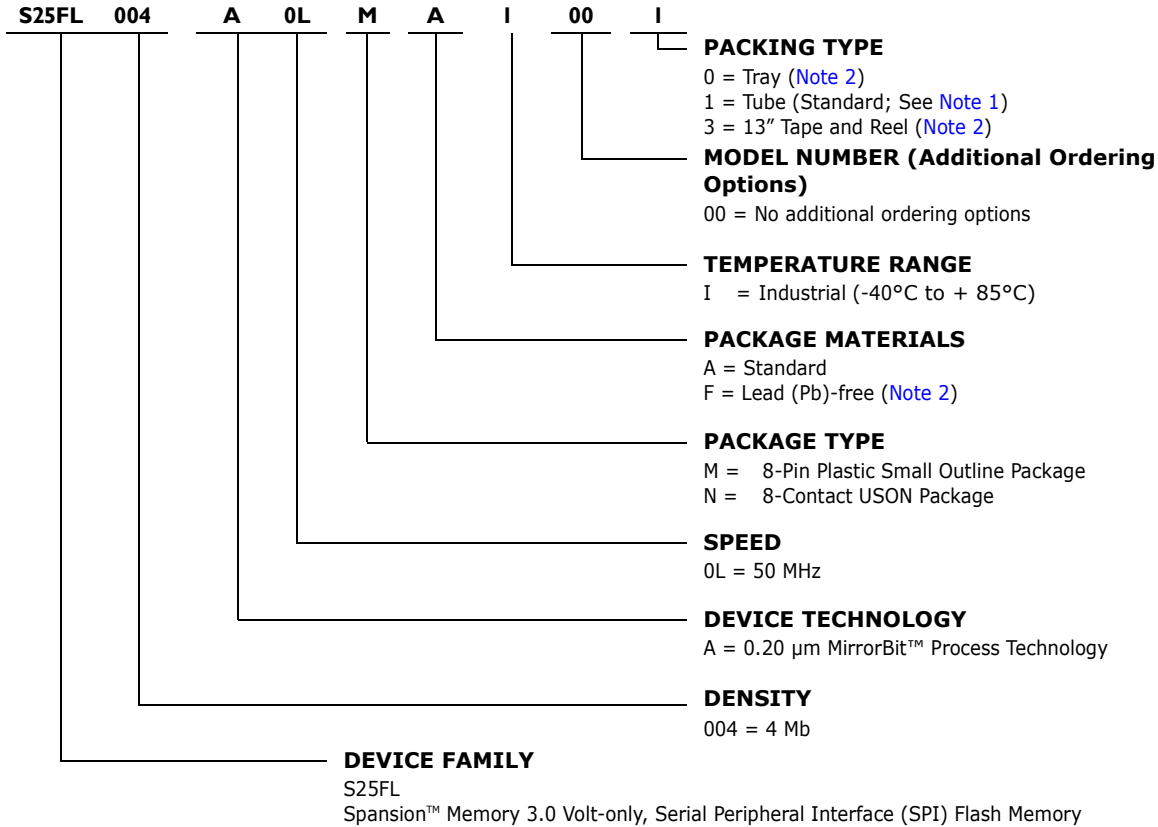

Table I. S25FL Valid Combinations Table

S25FL Valid Combinations					Package Marking (See Note 3)
Base Ordering Part Number	Speed Option	Package & Temperature	Model Number	Packing Type	
S25FL004A	0L	MAI, MFI NAI, NFI (Note 2)	00	0, 1, 3 (Note 1)	FL004A + (Temp) + (Note 4)

Notes:

1. Type 1 is standard. Specify other options as required.
2. Contact your local sales office for availability.
3. Package marking omits leading S25 and speed, package, and leading digit of model number from ordering part number.
4. A for standard package (non-Pb-free); F for Pb-free package.

Valid Combinations

Valid Combinations list configurations planned to be supported in volume for this device.

Signal Description

Signal Data Output (SO): This output signal is used to transfer data serially out from the device. Data is shifted out on the falling edge of Serial Clock (SCK).

Serial Data Input (SI): This input signal is used to transfer data serially into the device. It receives instructions, addresses, and the data to be programmed. Values are latched on the rising edge of Serial Clock (SCK).

Serial Clock (SCK): This input signal provides the serial interface timing. Instructions, addresses, and data present at the Serial Data input (SI) are latched on the rising edge of Serial Clock (SCK). Data on Serial Data Output (SO) changes after the falling edge of Serial Clock (SCK).

Chip Select (CS#): When this input signal is High, the device is deselected and Serial Data Output (SO) is at high impedance. Unless an internal Program, Erase or Write Status Register cycle is in progress, the device is in Standby mode. Driving Chip Select (CS#) Low enables the device, placing it in the active power mode.

After Power-up, a falling edge on Chip Select (CS#) is required prior to the start of any instruction.

Hold (HOLD#): The Hold (HOLD#) signal is used to pause any serial communications with the device without deselecting the device.

During the Hold instruction, the Serial Data Output (SO) is high impedance, and Serial Data Input (SI) and Serial Clock (SCK) are Don't Care.

To start the Hold condition, the device must be selected, with Chip Select (CS#) driven Low.

Write Protect (W#): The main purpose of this input signal is to freeze the area memory size that is protected against program or erase instructions (as specified by the values in the Status Register BP1 and BP0 bits).

SPI Modes

These devices can be driven by a microcontroller with its SPI peripheral running in either of two modes:

- CPOL = 0, CPHA = 0
- CPOL = 1, CPHA = 1

For these two modes, input data is latched in on the rising edge of Serial Clock (SCK), and output data is available from the falling edge of Serial Clock (SCK).

The difference between the two modes, as shown in [Figure 1, on page 9](#), is the clock polarity when the bus master is in Standby and not transferring data:

- SCK remains at 0 for (CPOL = 0, CPHA = 0)
- SCK remains at 1 for (CPOL = 1, CPHA = 1)

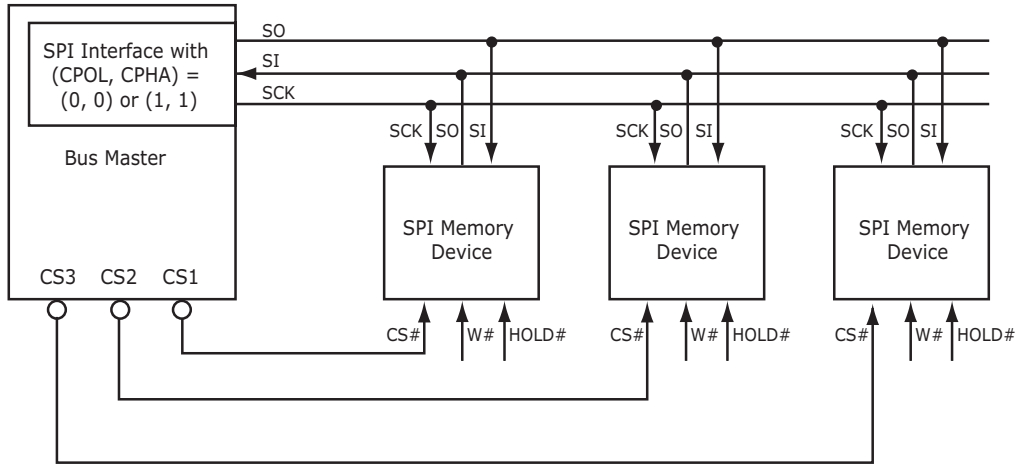

Note: The Write Protect (W#) and Hold (HOLD#) signals should be driven, High or Low as appropriate.

Figure 1. Bus Master and Memory Devices on the SPI Bus

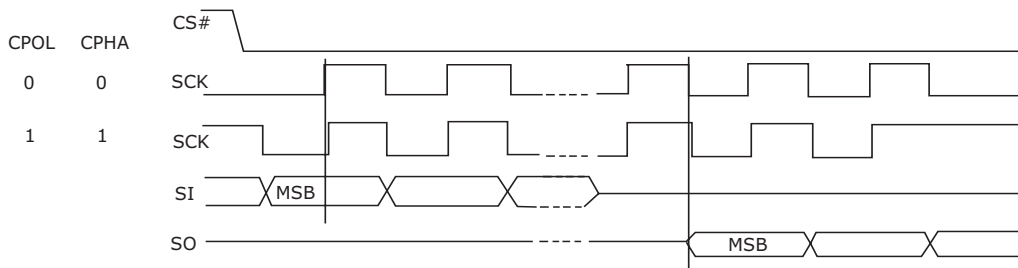

Figure 2. SPI Modes Supported

Operating Features

All device data into and out, is shifted in 8-bit chunks.

Page Programming

To program one data byte, two instructions are required: Write Enable (WREN), which is one byte, and a Page Program (PP) sequence, which consists of four bytes plus data. This is followed by the internal Program cycle. To spread this overhead, the Page Program (PP) instruction allows up to 256 bytes to be programmed at a time (changing bits from 1 to 0), provided that they lie in consecutive addresses on the same page of memory.

Sector Erase, or Bulk Erase

The Page Program (PP) instruction allows bits to be programmed from 1 to 0. Before this can be applied, the memory bytes need to be first erased to all 1's (FFh) before any programming. This can be achieved in two ways:

- A sector at a time using the Sector Erase (SE) instruction
- The entire memory, using the Bulk Erase (BE) instruction

Polling During a Write, Program, or Erase Cycle

A further improvement in the time to Write Status Register (WRSR), Program (PP) or Erase (SE or BE) can be achieved by not waiting for the worst-case delay. The Write in Progress (WIP) bit is provided in the Status Register so that the application program can monitor its value, polling it to establish when the previous Write cycle, Program cycle, or Erase cycle is complete.

Active Power and Standby Power Modes

When Chip Select (CS#) is Low, the device is enabled, and in the Active Power mode. When Chip Select (CS#) is High, the device is disabled, but could remain in the Active Power mode until all internal cycles have completed (Program, Erase, Write Status Register). The device then goes into the Standby Power mode. The device consumption drops to I_{SB} . This can be used as an extra Deep Power Down on mechanism, when the device is not in active use, to protect the device from inadvertent Write, Program, or Erase instructions.

Status Register

The Status Register contains a number of status and control bits, as shown in [Figure 7, on page 17](#) that can be read or set (as appropriate) by specific instructions

- **WIP bit:** The Write In Progress (WIP) bit indicates whether the memory is busy with a Write Status Register, Program or Erase cycle.
- **WEL bit:** The Write Enable Latch (WEL) bit indicates the internal Write Enable Latch status.
- **BP2, BP1, BP0 bits:** The Block Protect (BP2, BP1, BP0) bits are non-volatile. They define the area size to be software protected against Program and Erase instructions.
- **SRWD bit:** The Status Register Write Disable (SRWD) bit is operated in conjunction with the Write Protect (W#) signal. The Status Register Write Disable (SRWD) bit and Write Protect (W#) signal allow the device to be put in the Hardware Protected mode. In this mode, the Status Register's non-volatile bits (SRWD, BP2, BP1, BP0) become read-only bits.

Protection Modes

The SPI memory device boasts the following data protection mechanisms:

- All instructions that modify data must be preceded by a Write Enable (WREN) instruction to set the Write Enable Latch (WEL) bit. This bit is returned to its reset state by the following events:
 - Power-up
 - Write Disable (WRDI) instruction completion
 - Write Status Register (WRSR) instruction completion
 - Page Program (PP) instruction completion
 - Sector Erase (SE) instruction completion
 - Bulk Erase (BE) instruction completion
- The Block Protect (BP2, BP1, BP0) bits allow part of the memory to be configured as read-only. This is the Software Protected Mode (SPM).
- The Write Protect (W#) signal works in cooperation with the Status Register Write Disable (SRWD) bit to enable write-protection. This is the Hardware Protected Mode (HPM).
- Program, Erase and Write Status Register instructions are checked to verify that they consist of a number of clock pulses that is a multiple of eight, before they are accepted for execution.

Table 2. Protected Area Sizes (S25FL004A).

Protected Memory Area (Top Level)	Status Register Content			Memory Content	
	BP2 Bit	BP1 Bit	BP0	Protected Area	Unprotected Area
0	0	0	0	none	00000-7FFFF
1/8	0	0	1	70000-7FFFF	00000-6FFFF
1/4	0	1	0	60000-7FFFF	00000-5FFFF
1/2	0	1	1	40000-7FFFF	00000-3FFFF
All	1	0	0	00000-7FFFF	none
All	1	0	1	00000-7FFFF	none
All	1	1	0	00000-7FFFF	none
All	1	1	1	00000-7FFFF	none

Hold Condition Modes

The Hold (HOLD#) signal is used to pause any serial communications with the device without resetting the clocking sequence. Hold (HOLD#) signal gates the clock input to the device. However, taking this signal Low does not terminate any Write Status Register, Program or Erase Cycle that is currently in progress.

To enter the Hold condition, the device must be selected, with Chip Select (CS#) Low. The Hold condition starts on the falling edge of the Hold (HOLD#) signal, provided that this coincides with Serial Clock (SCK) being Low (as shown in [Figure 3, on page 12](#)).

The Hold condition ends on the rising edge of the Hold (HOLD#) signal, provided that this coincides with Serial Clock (SCK) being Low.

If the falling edge does not coincide with Serial Clock (SCK) being Low, the Hold condition starts after Serial Clock (SCK) next goes Low. Similarly, if the rising edge does not coincide with Serial Clock (SCK) being Low, the Hold condition ends after Serial Clock (SCK) next goes Low (Figure 3). During the Hold condition, the Serial Data Output (SO) is high impedance, and Serial Data Input (SI) and Serial Clock (SCK) are Don't Care.

Normally, the device remains selected, with Chip Select (CS#) driven Low, for the entire duration of the Hold condition. This ensures that the internal logic state remains unchanged from the moment of entering the Hold condition.

If Chip Select (CS#) goes High while the device is in the Hold condition, this has the effect of resetting the device's internal logic. To restart communication with the device, it is necessary to drive Hold (HOLD#) High, and then to drive Chip Select (CS#) Low. This prevents the device from going back to the Hold condition.

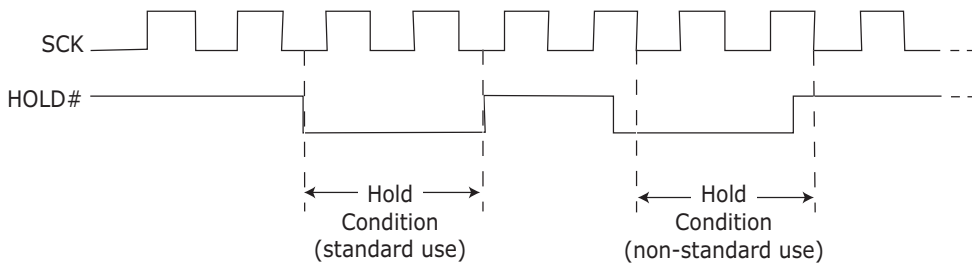

Figure 3. Hold Condition Activation

Memory Organization

The memory is organized as:

- S25FL004A: Eight sectors of 512 Kbit each.
- Each page can be individually programmed (bits are programmed from 1 to 0).
- The device is Sector or Bulk erasable (bits are erased from 0 to 1).

Table 3. Sector Address Table – S25FL004A

Sector	Address Range	
SA7	70000h	7FFFFh
SA6	60000h	6FFFFh
SA5	50000h	5FFFFh
SA4	40000h	4FFFFh
SA3	30000h	3FFFFh
SA2	20000h	2FFFFh
SA1	10000h	1FFFFh
SA0	00000h	0FFFFh

Instructions

All instructions, addresses, and data are shifted in and out of the device, starting with the most significant bit. Serial Data Input (SI) is sampled on the first rising edge of Serial Clock (SCK) after Chip Select (CS#) is driven Low. Then, the one-byte instruction code must be shifted in to the device, most significant bit first, on Serial Data Input (SI), each bit being latched on the rising edges of Serial Clock (SCK). The instruction set is listed in [Table 4, on page 15](#).

Every instruction sequence starts with a one-byte instruction code. Depending on the instruction, this might be followed by address bytes, or by data bytes, or by both or none. Chip Select (CS#) must be driven High after the last bit of the instruction sequence is shifted in.

In the case of a Read Data Bytes (READ), Read Status Register (RDSR), Read Data Bytes at higher speed (FAST_READ) and Read Identification (RDID) instructions, the shifted-in instruction sequence is followed by a data-out sequence. Chip Select (CS#) can be driven High after any bit of the data-out sequence is being shifted out to terminate the transaction.

In the case of a Page Program (PP), Sector Erase (SE), Bulk Erase (BE), Write Status Register (WRSR), Write Enable (WREN), or Write Disable (WRDI) instruction, Chip Select (CS#) must be driven High exactly at a byte boundary, otherwise the instruction is rejected, and is not executed. That is, Chip Select (CS#) must driven High when the number of clock pulses after Chip Select (CS#) being driven Low is an exact multiple of eight.

All attempts to access the memory array during a Write Status Register cycle, Program cycle or Erase cycle are ignored, and the internal Write Status Register cycle, Program cycle or Erase cycle continues unaffected

Table 4. Instruction Set

Instruction	Description	One-Byte Instruction Code	Address Bytes	Dummy Byte	Data Bytes
Status Register Operations					
WREN	Write Enable	06H (0000 0110)	0	0	0
WRDI	Write Disable	04H (0000 0100)	0	0	0
RDSR	Read from Status Register	05H (0000 0101)	0	0	1 to Infinity
WRSR	Write to Status Register	01H (0000 0001)	0	0	1
Read Operations					
READ	Read Data Bytes	03H (0000 0011)	3	0	1 to Infinity
FAST_READ	Read Data Bytes at Higher Speed	0BH (0000 1011)	3	1	1 to Infinity
RDID	Read Identification	9FH (1001 1111)	0	0	1 to 3
Erase Operations					
SE	Sector Erase	D8H (1101 1000)	3	0	0
BE	Bulk (Chip) Erase	C7H (1100 0111)	0	0	0
Program Operations					
PP	Page Program	02H (0000 0010)	3	0	1 to 256
Deep Power Down Savings Mode Operations					
DP	Deep Power Down	B9H (1011 1001)	0	0	0
RES	Release from Deep Power Down	ABH (1010 1011)	0	0	0
	Release from Deep Power Down and Read Electronic Signature	ABH (1010 1011)	0	3	1 to Infinity

Write Enable (WREN)

The Write Enable (WREN) instruction (Figure 4) sets the Write Enable Latch (WEL) bit. The Write Enable Latch (WEL) bit must be set prior to every Page Program (PP), Erase (SE or BE) and Write Status Register (WRSR) instruction. The Write Enable (WREN) instruction is entered by driving Chip Select (CS#) Low, sending the instruction code, and then driving Chip Select (CS#) High.

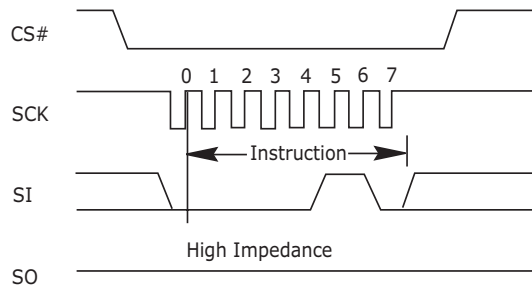

Figure 4. Write Enable (WREN) Instruction Sequence

Write Disable (WRDI)

The Write Disable (WRDI) instruction (Figure 5) resets the Write Enable Latch (WEL) bit. The Write Disable (WRDI) instruction is entered by driving Chip Select (CS#) Low, sending the instruction code, and then driving Chip Select (CS#) High.

The Write Enable Latch (WEL) bit is reset under the following conditions:

- Power-up
- Write Disable (WRDI) instruction completion
- Write Status Register (WRSR) instruction completion
- Page Program (PP) instruction completion
- Sector Erase (SE) instruction completion
- Bulk Erase (BE) instruction completion.

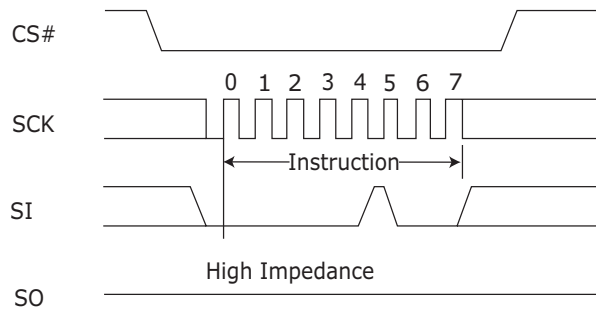

Figure 5. Write Disable (WRDI) Instruction Sequence

Read Status Register (RDSR)

The Read Status Register (RDSR) instruction allows the Status Register to be read. The Status Register may be read at any time, even while a Program, Erase, or Write Status Register cycle is in progress. When one of these cycles is in progress, it is recommended to check the Write In Progress (WIP) bit before sending a new instruction to the device. It is also possible to read the Status Register continuously, as shown in Figure 6.

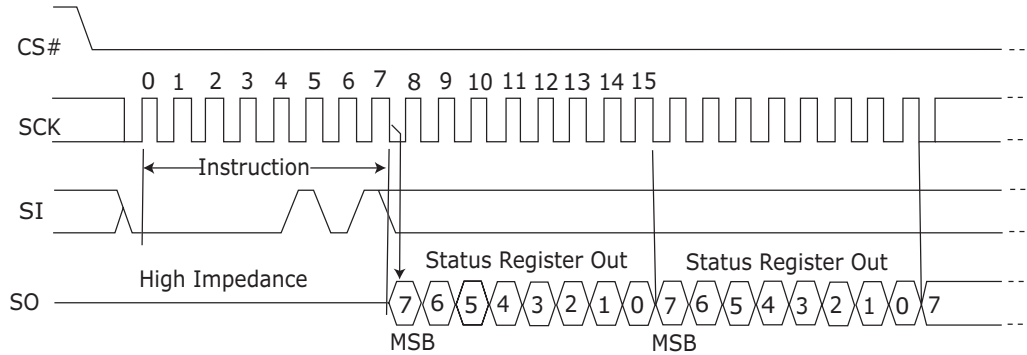

Figure 6. Read Status Register (RDSR) Instruction Sequence

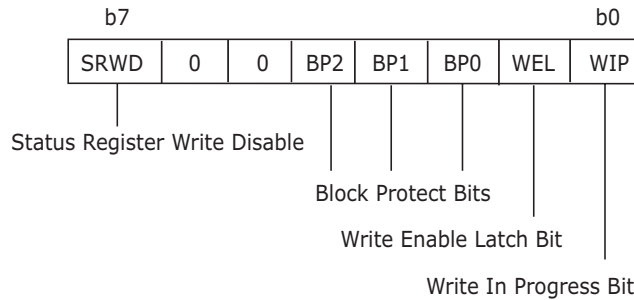

Figure 7. Status Register Format

The status and control bits of the Status Register are as follows:

SRWD bit: The Status Register Write Disable (SRWD) bit is operated in conjunction with the Write Protect (W#) signal. The Status Register Write Disable (SRWD) bit and Write Protect (W#) signal allow the device to be put in the Hardware Protected mode (when the Status Register Write Disable (SRWD) bit is set to 1, and Write Protect (W#) is driven Low). In this mode, the non-volatile bits of the Status Register (SRWD, BP2, BP1, BP0) become read-only bits and the Write Status Register (WRSR) instruction is no longer accepted for execution.

BP2, BP1, BP0 bits: The Block Protect (BP2, BP1, BP0) bits are non-volatile. They define the area size to be software protected against Program and Erase instructions. These bits are written with the Write Status Register (WRSR) instruction. When one or both of the Block Protect (BP2, BP1, BP0) bits is set to 1, the relevant memory area (as defined in Table 2, on page 11) becomes protected against Page Program (PP), and Sector Erase (SE) instructions. The Block Protect (BP2, BP1, BP0) bits can be written provided that the Hardware Protected mode has not been set. The Bulk Erase (BE) instruction is executed if, and only if, all Block Protect (BP2, BP1, BP0) bits are 0.

WEL bit: The Write Enable Latch (WEL) bit indicates the internal Write Enable Latch status. When set to 1, the internal Write Enable Latch is set; when set to 0, the internal Write Enable Latch is reset and no Write Status Register, Program or Erase instruction is accepted.

WIP bit: The Write In Progress (WIP) bit indicates whether the memory is busy with a Write Status Register, Program or Erase cycle. This bit is a read only bit and is read by executing a RDSR instruction. If this bit is 1, such a cycle is in progress, if it is 0, no such cycle is in progress.

Write Status Register (WRSR)

The Write Status Register (WRSR) instruction allows new values to be written to the Status Register. Before it can be accepted, a Write Enable (WREN) instruction must previously have been executed. After the Write Enable (WREN) instruction is decoded and executed, the device sets the Write Enable Latch (WEL).

The Write Status Register (WRSR) instruction is entered by driving Chip Select (CS#) Low, followed by the instruction code and the data byte on Serial Data Input (SI).

The instruction sequence is shown in [Figure 8](#).

The Write Status Register (WRSR) instruction has no effect on bits b6, b5, b1 and b0 of the Status Register. Bits b6 and b5 are always read as 0.

Chip Select (CS#) must be driven High after the eighth bit of the data byte is latched in. If not, the Write Status Register (WRSR) instruction is not executed. As soon as Chip Select (CS#) is driven High, the self-timed Write Status Register cycle (whose duration is t_w) is initiated. While the Write Status Register cycle is in progress, the Status Register may still be read to check the Write In Progress (WIP) bit value. The Write In Progress (WIP) bit is 1 during the self-timed Write Status Register cycle, and is 0 when it is completed. At some unspecified time before the cycle is completed, the Write Enable Latch (WEL) is reset.

The WRSR instruction enables the user to select one of seven levels of protection. The S25FL004A is divided into eight array segments. The top eighth, quarter, half, or all of the memory segments can be protected (as defined in [Table 1, on page 7](#)). The data within a selected segment is therefore read-only. The Write Status Register (WRSR) instruction also allows the user to set or reset the Status Register Write Disable (SRWD) bit in accordance with the Write Protect (W#) signal. The Status Register Write Disable (SRWD) bit and Write Protect (W#) signal allow the device to be put in the Hardware Protected Mode (HPM). The Write Status Register (WRSR) instruction cannot be executed once the Hardware Protected Mode (HPM) is entered.

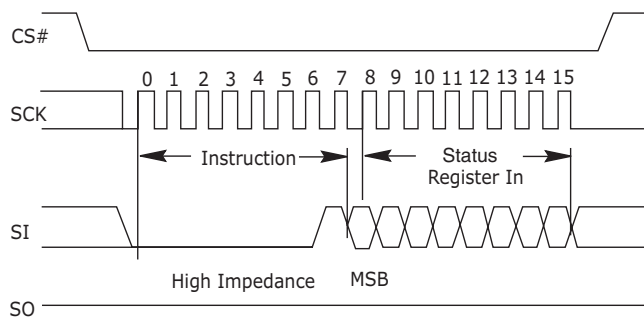

Figure 8. Write Status Register (WRSR) Instruction Sequence

Table 5. Protection Modes

W# Signal	SRWD Bit	Mode	Status Register Write Protection	Protected Area (See Note)	Unprotected Area (See Note)
1	1	Software Protected (SPM)	Status Register is Writable (if the WREN instruction sets the WEL bit) The values in the SRWD, BP2, BP1 and BP0 bits can be changed	Protected against Page Program and Erase (SE, BE)	Ready to accept Page Program and Sector Erase Instructions
1	0				
0	0				
0	1	Hardware Protected (HPM)	Status Register is Hardware write protected The values in the SRWD, BP2, BP1 and BP0 bits cannot be changed	Protected against Page Program and Erase (SE, BE)	Ready to accept Page Program and Sector Erase Instructions

Note: As defined by the values in the Block Protect (BP2, BP1, BP0) bits of the Status Register, as shown in [Table 2, on page 11](#).

The device protection features are summarized in [Table 5](#).

When the Status Register Write Disable (SRWD) bit is 0 (its initial delivery state), it is possible to write to the Status Register provided that the Write Enable Latch (WEL) bit has previously been set by a Write Enable (WREN) instruction, regardless of whether Write Protect (W#) is driven High or Low.

When the Status Register Write Disable (SRWD) bit is set to 1, two cases need to be considered, depending on the state of Write Protect (W#):

- If Write Protect (W#) is driven High, it is possible to write to the Status Register provided that the Write Enable Latch (WEL) bit has previously been set by a Write Enable (WREN) instruction.
- If Write Protect (W#) is driven Low, it is not possible to write to the Status Register even if the Write Enable Latch (WEL) bit has previously been set by a Write Enable (WREN) instruction. (Attempts to write to the Status Register are rejected, and are not accepted for execution). As a consequence, all the data bytes in the memory area that are software protected (SPM) by the Block Protect (BP1, BP0) bits of the Status Register, are also hardware protected against data modification.

Regardless of the two events order, the Hardware Protected Mode (HPM) can be entered:

- By setting the Status Register Write Disable (SRWD) bit after driving Write Protect (W#) Low
or
- By driving Write Protect (W#) Low after setting the Status Register Write Disable (SRWD) bit.

The only way to exit the Hardware Protected Mode (HPM) once entered is to pull Write Protect (W#) High.

If Write Protect (W#) is permanently tied High, the Hardware Protected Mode (HPM) can never be activated, and only the Software Protected Mode (SPM), using the Status Register's Block Protect (BP2, BP1, BP0) bits, can be used.

Read Data Bytes (READ)

The READ instruction reads the memory at the specified SCK frequency (f_{SCK}) with a maximum speed of 33 MHz.

The device is first selected by driving Chip Select (CS#) Low. The instruction code for the Read Data Bytes (READ) instruction is followed by a 3-byte address (A23-A0), each bit being latched-in during the rising edge of Serial Clock (SCK). Then the memory contents, at that address, are shifted out on Serial Data Output (SO), each bit being shifted out, at a frequency f_{SCK} , during the falling edge of Serial Clock (SCK).

The instruction sequence is shown in Figure 9. The first byte addressed can be at any location. The address automatically increments to the next higher address after each byte of data is shifted out. The whole memory can, therefore, be read with a single Read Data Bytes (READ) instruction. When the highest address is reached, the address counter rolls over to 00000h, allowing the read sequence to be continued indefinitely.

The Read Data Bytes (READ) instruction is terminated by driving Chip Select (CS#) High. Chip Select (CS#) can be driven High at any time during data output. Any Read Data Bytes (READ) instruction, while a Program, Erase, or Write cycle is in progress, is rejected without having any effect on the cycle that is in progress.

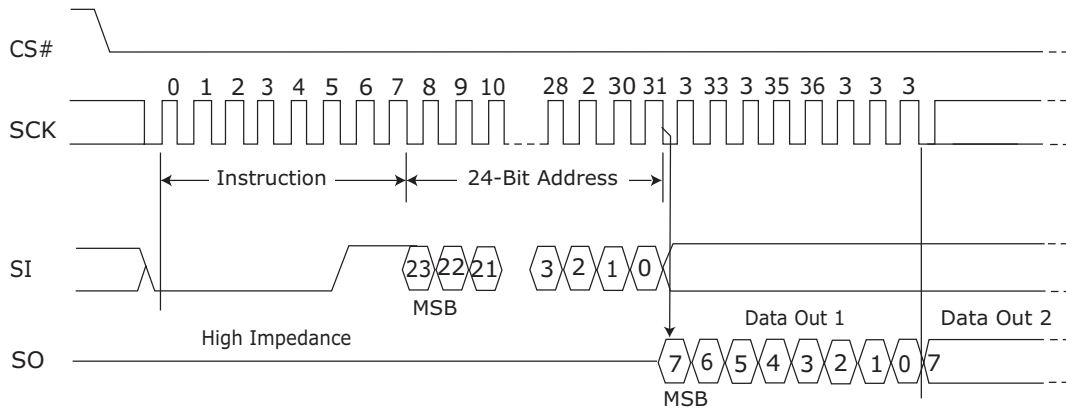

Figure 9. Read Data Bytes (READ) Instruction Sequence

Read Data Bytes at Higher Speed (FAST_READ)

The FAST_READ instruction reads the memory at the specified SCK frequency (f_{SCK}) with a maximum speed of 50 MHz. The device is first selected by driving Chip Select (CS#) Low. The instruction code for (FAST_READ) instruction is followed by a 3-byte address (A23-A0) and a dummy byte, each bit being latched-in during the rising edge of Serial Clock (SCK). Then the memory contents, at that address, are shifted out on Serial Data Output (SO), each bit being shifted out, at a maximum frequency F_{SCK} , during the falling edge of Serial Clock (SCK).

The instruction sequence is shown in Figure 10, on page 21. The first byte addressed can be at any location. The address automatically increments to the next higher address after each byte of data is shifted out. The whole memory can, therefore, be read with a single (FAST_READ) instruction. When the highest address is reached, the address counter rolls over to 00000h, allowing the read sequence to be continued indefinitely.

The (FAST_READ) instruction is terminated by driving Chip Select (CS#) High. Chip Select (CS#) can be driven High at any time during data output. Any (FAST_READ) instruction, while an Erase, Program or Write cycle is in progress, is rejected without having any effects on the cycle that is in progress.

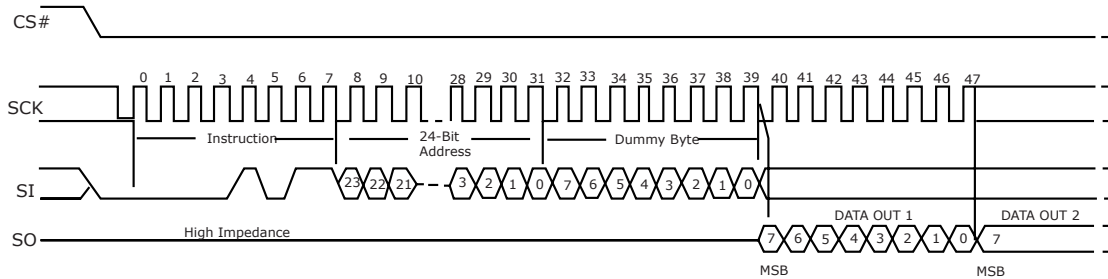

Figure 10. Read Data Bytes at Higher Speed (FAST_READ) Instruction Sequence

Read Identification (RDID)

The Read Identification (RDID) instruction allows the 8-bit manufacturer identification to be read, followed by two bytes of the device identification.

The manufacturer identification byte is assigned by JEDEC, and has a value of 01h for Spansion™ products. The device identification is assigned by the device manufacturer, and indicates the memory type in the first byte (02h), and the device’s memory capacity in the second byte (12h).

Any Read Identification (RDID) instruction executed while an Erase, Program, or Write Status Register cycle is in progress is not decoded, and has no effect on the cycle that is in progress.

The device is first selected by driving Chip Select (CS#) Low. Then, the 8-bit instruction code for the instruction is shifted in, with each bit being latched in on SI during the rising edge of SCK. This is followed by the 24-bit device identification, stored in the memory, being shifted out on Serial Data Output (SO), with each bit being shifted out during the falling edge of Serial Clock (SCK).

The instruction sequence is shown in [Figure 11](#).

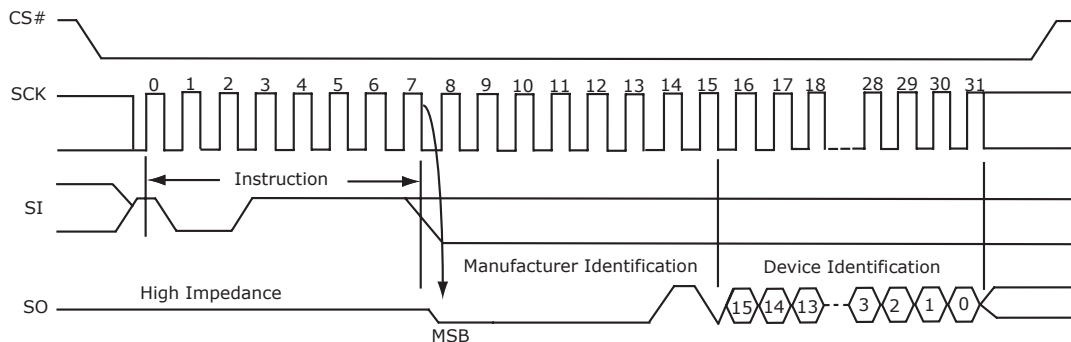

Figure 11. Read Identification (RDID) Instruction Sequence and Data-Out Sequence

Driving CS# high after the Device Identification is read at least once, terminates the READ_ID instruction. The Read Identification (RDID) instruction can also be terminated by driving CS# High at any time during data output.

When Chip Select (CS#) is driven High, the device is put in the Stand-by Power mode. Once in the Stand-by Power mode, the device waits to be selected, so that it can receive, decode and execute instructions.

Table 6. Read Identification (RDID) Data-Out Sequence

Manufacturer Identification	Device Identification	
	Memory Type	Memory Capacity
01h	02h	12h

Page Program (PP)

The Page Program (PP) instruction allows bytes to be programmed in the memory (changing bits from 1 to 0). Before it can be accepted, a Write Enable (WREN) instruction must previously have been executed. After the Write Enable (WREN) instruction is decoded, the device sets the Write Enable Latch (WEL).

The Page Program (PP) instruction is entered by driving Chip Select (CS#) Low, followed by the instruction code, three address bytes and at least one data byte on Serial Data Input (SI). Chip Select (CS#) must be driven Low for the entire sequence duration.

The instruction sequence is shown in [Figure 12, on page 23](#).

If more than 256 bytes are sent to the device, the addressing wraps to the beginning of the same page, previously latched data are discarded and the last 256 data bytes are guaranteed to be programmed correctly within the same page. If fewer than 256 Data bytes are sent to device, they are correctly programmed at the requested addresses without having any effects on the other bytes of the same page.

Chip Select (CS#) must be driven High after the eighth bit of the last data byte is latched in, otherwise the Page Program (PP) instruction is not executed. As soon as Chip Select (CS#) is driven High, the self-timed Page Program cycle (whose duration is t_{pp}) is initiated. While the Page Program cycle is in progress, the Status Register may be read to check the Write In Progress (WIP) bit value. The Write In Progress (WIP) bit is 1 during the self-timed Page Program cycle, and is 0 when it is completed. At some unspecified time before the cycle is completed, the Write Enable Latch (WEL) bit is reset.

A Page Program (PP) instruction applied to a page that is protected by the Block Protect (BP2, BP1, BP0) bits (see [Table 2, on page 11](#)) is not executed.

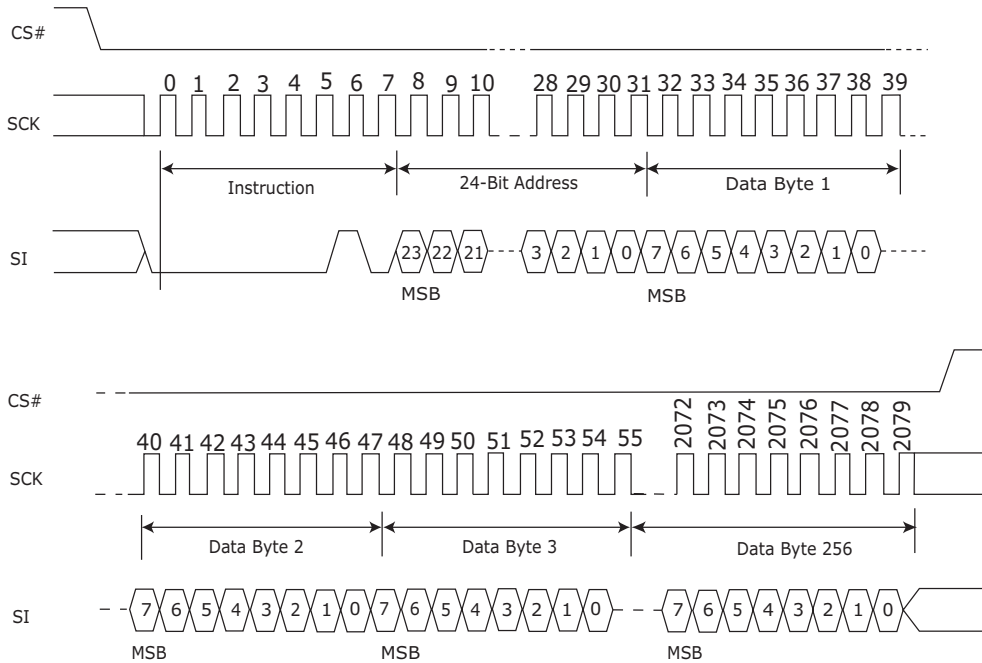

Figure 12. Page Program (PP) Instruction Sequence

Sector Erase (SE)

The Sector Erase (SE) instruction sets to 1 (FFh) all bits inside the chosen sector. Before it can be accepted, a Write Enable (WREN) instruction must previously have been executed. After the Write Enable (WREN) instruction is decoded, the device sets the Write Enable Latch (WEL).

The Sector Erase (SE) instruction is entered by driving Chip Select (CS#) Low, followed by the instruction code, and three address bytes on Serial Data Input (SI). Any address inside the Sector (see [Table 2, on page 11](#)) is a valid address for the Sector Erase (SE) instruction. Chip Select (CS#) must be driven Low for the entire sequence duration.

The instruction sequence is shown in [Figure 13, on page 24](#).

Chip Select (CS#) must be driven High after the eighth bit of the last address byte is latched in, otherwise the Sector Erase (SE) instruction is not executed. As soon as Chip Select (CS#) is driven High, the self-timed Sector Erase cycle (whose duration is tSE) is initiated. While the Sector Erase cycle is in progress, the Status Register may be read to check the Write In Progress (WIP) bit value. The Write In Progress (WIP) bit is 1 during the self-timed Sector Erase cycle, and is 0 when it is completed. At some unspecified time before the cycle is completed, the Write Enable Latch (WEL) bit is reset.

A Sector Erase (SE) instruction applied to any memory area that is protected by the Block Protect (BP2, BP1, BP0) bits (see [Table 2, on page 11](#)) is not executed.

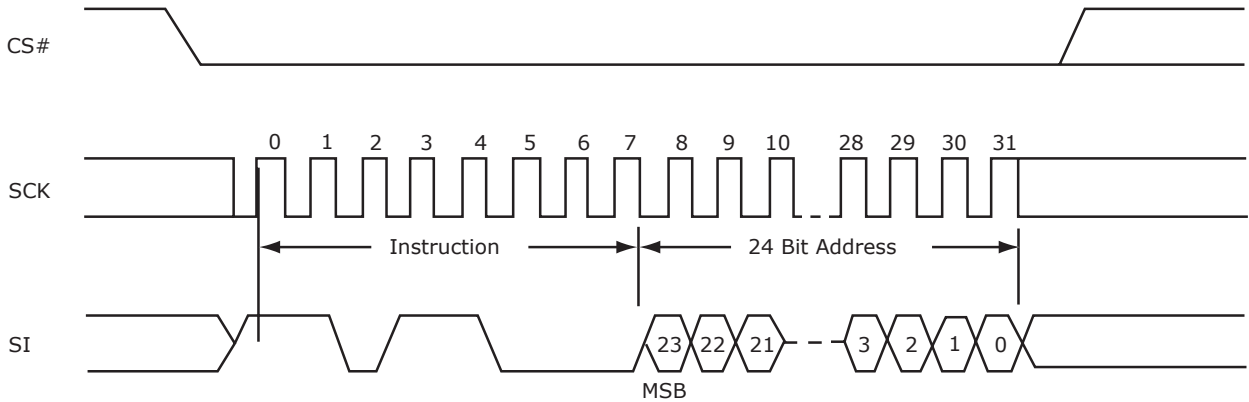

Figure I3. Sector Erase (SE) Instruction Sequence

Bulk Erase (BE)

The Bulk Erase (BE) instruction sets to 1 (FFh) all bits inside the entire memory. Before it can be accepted, a Write Enable (WREN) instruction must previously have been executed. After the Write Enable (WREN) instruction is decoded, the device sets the Write Enable Latch (WEL).

The Bulk Erase (BE) instruction is entered by driving Chip Select (CS#) Low, followed by the instruction code, on Serial Data Input (SI). No address is required for the Bulk Erase (BE) instruction. Chip Select (CS#) must be driven Low for the entire sequence duration.

The instruction sequence is shown in [Figure 14, on page 25](#).

Chip Select (CS#) must be driven High after the eighth bit of the last address byte is latched in, otherwise the Bulk Erase (BE) instruction is not executed.

As soon as Chip Select (CS#) is driven High, the self-timed Bulk Erase cycle (whose duration is t_{BE}) is initiated. While the Bulk Erase cycle is in progress, the Status Register may be read to check the value of the Write In Progress (WIP) bit. The Write In Progress (WIP) bit is 1 during the self-timed Bulk Erase cycle, and is 0 when it is completed. At some unspecified time before the cycle is completed, the Write Enable Latch (WEL) bit is reset.

A Bulk Erase (BE) instruction is executed only if all the Block Protect (BP2, BP1, BP0) bits (see [Table 2, on page 11](#)) are set to 0. The Bulk Erase (BE) instruction is ignored if one or more sectors are protected.

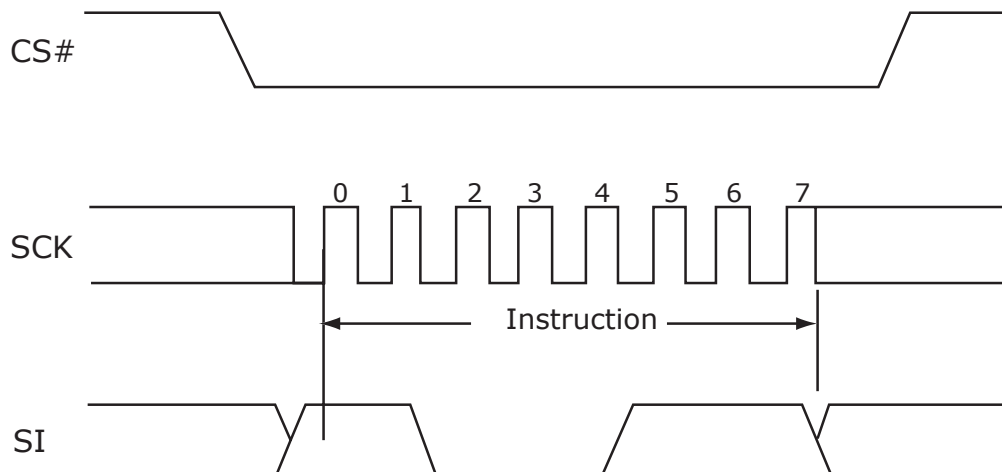

Figure 14. Bulk Erase (BE) Instruction Sequence

Deep Power Down (DP)

The Deep Power Down (DP) instruction puts the device in the lowest current mode of 1 μ A typical.

It is recommended that the standard Standby mode be used for the lowest power current draw, as well as the Deep Power Down (DP) as an extra software protection mechanism when this device is not in active use. In this mode, the device ignores all Write, Program, and Erase instructions. Chip Select (CS#) must be driven Low for the entire sequence duration.

The Deep Power Down (DP) instruction is entered by driving Chip Select (CS#) Low, followed by the instruction code on Serial Data Input (SI). Chip Select (CS#) must be driven Low for the entire sequence duration.

The instruction sequence is shown in [Figure 15, on page 26](#).

Driving Chip Select (CS#) High after the eighth bit of the instruction code is latched, places the device in Deep Power Down mode. The Deep Power Down mode can only be entered by executing the Deep Power Down (DP) instruction to reduce the standby current (from I_{SB} to I_{DP} as specified in [Table 8, on page 30](#)). As soon as Chip Select (CS#) is driven high, it requires a delay of t_{DP} currently in progress before Deep Power Down mode is entered.

Once the device enters the Deep Power Down mode, all instructions are ignored except the Release from Deep Power Down (RES) and Read Electronic Signature. This releases the device from the Deep Power Down mode. The Release from Deep Power Down and Read Electronic Signature (RES) instruction also allows the device's Electronic Signature to be output on Serial Data Output (SO).

The Deep Power Down mode automatically stops at Power-down, and the device always powers up in the Standby mode.

Any Deep Power Down (DP) instruction, while an Erase, Program, or WRSR cycle is in progress, is rejected without having any effect on the cycle in progress.

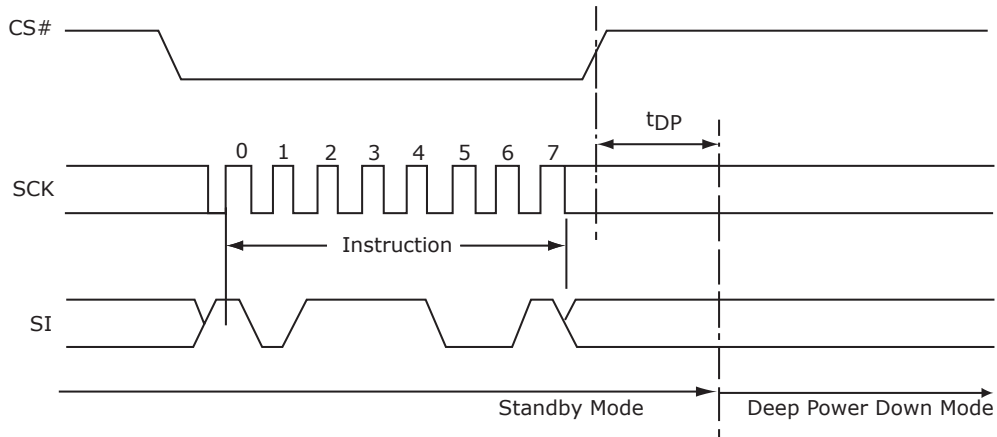

Figure 15. Deep Power Down (DP) Instruction Sequence

Release from Deep Power Down (RES)

The Release from Deep Power Down (RES) instruction provides the only way to exit the Deep Power Down mode. Once the device enters the Deep Power Down mode, all instructions are ignored except the Release from Deep Power Down (RES) instruction. Executing this instruction takes the device out of Deep Power Down mode.

The Release from Deep Power Down (RES) instruction is entered by driving Chip Select (CS#) Low, followed by the instruction code on Serial Data Input (SI). Chip Select (CS#) must be driven Low for the entire sequence duration.

The instruction sequence is shown in [Figure 16, on page 27](#).

Driving Chip Select (CS#) High after the 8-bit instruction byte is received by the device, but before the whole of the 8-bit Electronic Signature is transmitted for the first time, still insures that the device is placed into Standby mode. If the device was previously in the Deep Power Down mode, the transition to the Standby Power mode is delayed by t_{RES} , and Chip Select (CS#) must remain High for at least $t_{RES(max)}$, as specified in [Table 10, on page 32](#). Once in the Stand-by Power mode, the device waits to be selected, so that it can receive, decode, and execute instructions.

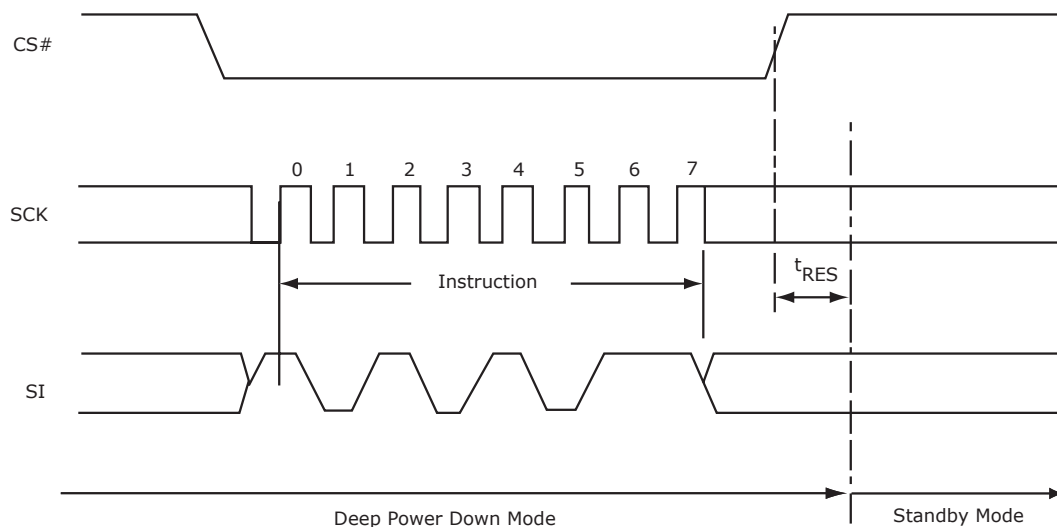

Figure 16. Release from Deep Power Down Instruction Sequence

Release from Deep Power Down and Read Electronic Signature (RES)

Once the device enters Deep Power Down mode, all instructions are ignored except the RES instruction. The RES instruction can also be used to read the old-style 8-bit Electronic Signature on the SO pin. The RES instruction always provides access to the Electronic Signature (except while an Erase, Program or WRSR cycle is in progress), and can be applied even if DP mode is not entered. Any RES instruction executed while an Erase, Program, or WRSR cycle is in progress is not decoded, and has no effect on the cycle in progress.

The device features an 8-bit Electronic Signature, whose value for the S25FL004A is 12h. This can be read using RES instruction.

The device is first selected by driving Chip Select (CS#) Low. The instruction code is followed by three dummy bytes, each bit being latched-in on Serial Data Input (SI) during the rising edge of Serial Clock (SCK). Then, the 8-bit Electronic Signature, stored in the memory, is shifted out on Serial Data Output (SO), each bit being shifted out during the falling edge of Serial Clock (SCK).

The instruction sequence is shown in [Figure 17, on page 28](#).

The Release from Deep Power Down and Read Electronic Signature (RES) is terminated by driving Chip Select (CS#) High after the Electronic Signature is read at least once. Sending additional clock cycles on Serial Clock (SCK), while Chip Select (CS#) is driven Low, causes the Electronic Signature to be output repeatedly.

When Chip Select (CS#) is driven High, the device is placed in the Stand-by Power mode. If the device was not previously in the Deep Power Down mode, the transition to the Stand-by Power mode is immediate. If the device was previously in the Deep Power Down mode, the transition to the Standby mode is delayed by t_{RES} , and Chip Select (CS#) must remain High for at least $t_{RES(max)}$, as specified in [Table 10, on page 32](#). Once in the Stand-by Power mode, the device waits to be selected, so that it can receive, decode, and execute instructions.

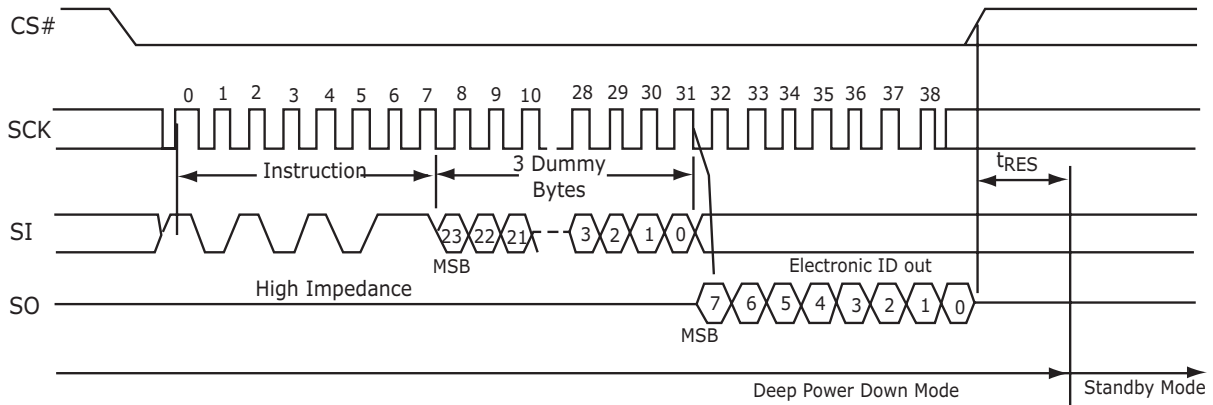

Figure 17. Release from Deep Power Down and Read Electronic Signature (RES) Instruction Sequence

Power-up and Power-down

The device must not be selected at power-up or power-down (that is, CS# must follow the voltage applied on V_{CC}) until V_{CC} reaches the correct value as follows:

- V_{CC} (min) at power-up, and then for a further delay of t_{PU} (as described in [Table 7, on page 29](#))
- V_{SS} at power-down

A simple pull-up resistor on Chip Select (CS#) can usually be used to insure safe and proper power-up and power-down.

The device ignores all instructions until a time delay of t_{PU} (as described in [Table 7, on page 29](#)) has elapsed after the moment that V_{CC} rises above the minimum V_{CC} threshold. However, device correct operation is not guaranteed if by this time V_{CC} is still below V_{CC} (min). No Write Status Register, Program, or Erase instructions should be sent until t_{PU} after V_{CC} reaches the minimum V_{CC} threshold.

At power-up, the device is in Standby mode (not Deep Power Down mode) and the WEL bit is reset.

Normal precautions must be taken for supply rail decoupling to stabilize the $V_{CC(min)}$ feed. Each device in a system should have the V_{CC} rail decoupled by a suitable capacitor close to the package pins (this capacitor is generally in the order of 0.1 μ F).

At power-down, when V_{CC} drops from the operating voltage to below the $V_{CC(min)}$ threshold, all operations are disabled and the device does not respond to any instructions. (The designer needs to be aware that if a power-down occurs while a Write, Program, or Erase cycle is in progress, data corruption can result.)

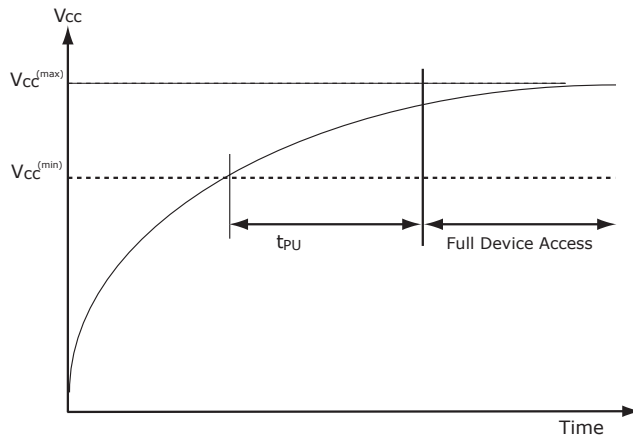

Figure 18. Power-Up Timing

Table 7. Power-Up Timing

Symbol	Parameter	Min	Max	Unit
$V_{CC(min)}$	V_{CC} (minimum)	2.7		V
t_{PU}	V_{CC} (min) to device operation	10		mSec

Initial Delivery State

The device is delivered with all bits set to 1 (each byte contains FFh). The Status Register contains 00h (all Status Register bits are 0).

Maximum Rating

Stressing the device above the rating listed in the **Absolute Maximum Ratings** section may cause permanent damage to the device. These are stress ratings only and operating the device at these or any other conditions above those indicated in the Operating sections of this specification, is not implied. Exposure to Absolute Maximum Rating conditions for extended periods may affect device reliability.

Absolute Maximum Ratings

- Ambient Storage Temperature -65°C to +150°C
- Voltage with Respect to Ground:
- All Inputs and I/Os. -0.3 V to 4.5 V

Operating Ranges

Ambient Operating Temperature (T_A)

- Commercial 0°C to +70°C
- Industrial -40°C to +85°C

Positive Power Supply

- Voltage Range 2.7 V to 3.6 V

Note: Operating ranges define those limits between which the device functionality is guaranteed.

DC Characteristics

This section summarizes the device DC and AC Characteristics. Designers should check that the operating conditions in their circuit match the measurement conditions specified in the Test Specifications in [Table 9, on page 31](#), when relying on the quoted parameters.

CMOS Compatible

Table 8. DC Characteristics

Parameter	Description	Test Conditions (See Note)		Min	Typ.	Max	Unit
V_{CC}	Supply Voltage			2.7	3	3.6	V
I_{CC1}	Active Read Current	$SCK = 0.1 V_{CC}/0.9V_{CC}$	33 MHz			6	mA
		$SCK = 0.1 V_{CC}/0.9V_{CC}$	$V_{CC} = 3.0V$ 50 MHz			11	mA
I_{CC2}	Active Page Program Current	$CS\# = V_{CC}$				20	mA
I_{CC3}	Active WRSR Current	$CS\# = V_{CC}$				24	mA
I_{CC4}	Active Sector Erase Current	$CS\# = V_{CC}$				24	mA
I_{CC5}	Active Bulk Erase Current	$CS\# = V_{CC}$				24	mA
I_{SB}	Standby Current	$V_{CC} = 3.0 V$ $CS\# = V_{CC}$				50	μA
I_{DP}	Deep Power Down Current	$V_{CC} = 3.0 V$ $CS\# = V_{CC}$			1	10	μA
I_{LI}	Input Leakage Current	$V_{IN} = GND \text{ to } V_{CC}$				1	μA
I_{LO}	Output Leakage Current	$V_{IN} = GND \text{ to } V_{CC}$				1	μA
V_{IL}	Input Low Voltage			-0.3		$0.3 V_{CC}$	V
V_{IH}	Input High Voltage			$0.7 V_{CC}$		$V_{CC} + 0.5$	V
V_{OL}	Output Low Voltage	$I_{OL} = 1.6 \text{ mA}, V_{CC} = V_{CC \text{ min}}$				0.4	V
V_{OH}	Output High Voltage	$I_{OH} = -0.1 \text{ mA}$		$V_{CC} - 0.2$			V

Note: Typical values are at $T_A = 25^\circ C$ and 3.0 V.

Test Conditions

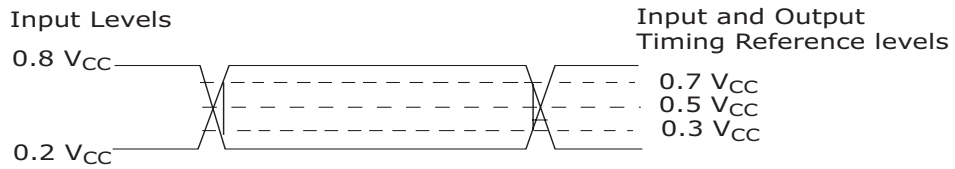

Figure 19. AC Measurements I/O Waveform

Table 9. Test Specifications

Symbol	Parameter	Min	Max	Unit
C_L	Load Capacitance	30		pF
	Input Rise and Fall Times		5	ns
	Input Pulse Voltage	0.2 V_{CC} to 0.8 V_{CC}		V
	Input Timing Reference Voltage	0.3 V_{CC} to 0.7 V_{CC}		V
	Output Timing Reference Voltage	0.5 V_{CC}		V

AC Characteristics

Table 10. AC Characteristics

Symbol	Parameter	Min	Typ	Max	Unit
F_{SCK}	SCK Clock Frequency READ instruction	D.C.		33	MHz
F_{SCK}	SCK Clock Frequency for: FAST_READ, PP, SE, BE, DP, RES, WREN, WRDI, RDSR, WRSR	D.C.		50	MHz
t_{CRT}	Clock Rise Time (Slew Rate)	0.1			V/ns
t_{CFT}	Clock Fall Time (Slew Rate)	0.1			V/ns
t_{WH}	SCK High Time	9			ns
t_{WL}	SCK Low Time	9			ns
t_{CS}	CS# High Time	100			ns
t_{CSS} (See Note 3)	CS# Setup Time	5			ns
t_{CSH} (See Note 3)	CS# HOLD Time	5			ns
t_{HD} (See Note 3)	HOLD# Setup Time (relative to SCK)	5			ns
t_{CD} (See Note 3)	HOLD# Hold Time (relative to SCK)	5			ns
t_{HC}	HOLD# Setup Time (relative to SCK)	5			ns
t_{CH}	HOLD# Hold Time (relative to SCK)	5			ns
t_V	Output Valid			10	ns
t_{HO}	Output Hold Time	0		10	ns
$t_{HD:DAT}$	Data in Hold Time	5			ns
$t_{SU:DAT}$	Data in Setup Time	5			ns
t_R	Input Rise Time			5	ns
t_F	Input Fall Time			5	ns
t_{LZ} (See Note 3)	HOLD# to Output Low Z			10	ns
t_{HZ} (See Note 3)	HOLD# to Output High Z			10	ns
t_{DIS} (See Note 3)	Output Disable Time			10	ns
t_{WPS} (See Note 3)	Write Protect Setup Time	15			ns
t_{WPH} (See Note 3)	Write Protect Hold Time	15			ns
t_W	Write Status Register Time			65	ms
t_{DP}	CS# High to Deep Power Down Mode			3	μ s
t_{RES}	Release DP Mode			30	μ s
t_{PP}	Page Programming Time		1.5 (See Note 1)	3 (See Note 2)	ms
t_{SE}	Sector Erase Time		1.5 (See Note 1)	3 (See Note 2)	sec
t_{BE}	Bulk Erase Time		12 (See Note 1)	24 (See Note 2)	sec

Note:

1. Typical program and erase times assume the following conditions: 25°C, VCC = 3.0V; 10, 000 cycles; checkerboard data pattern
2. Under worst-case conditions of 90°C; VCC = 2.7V; 100,000 cycles
3. Not 100% tested

AC Characteristics

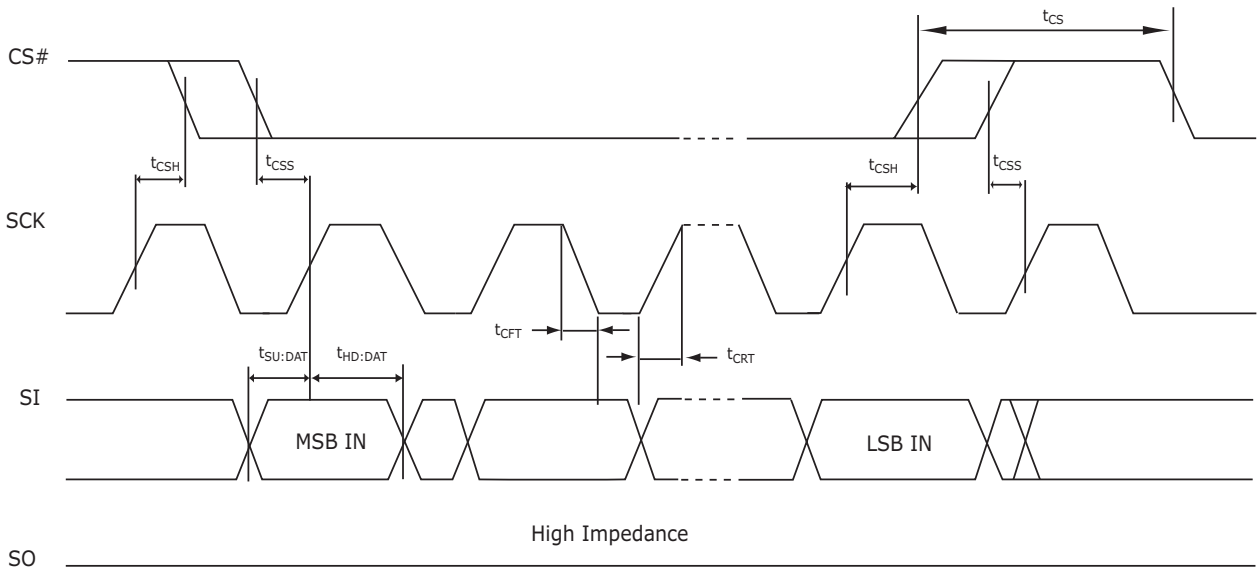

Figure 20. SPI Mode 0 (0,0) Input Timing

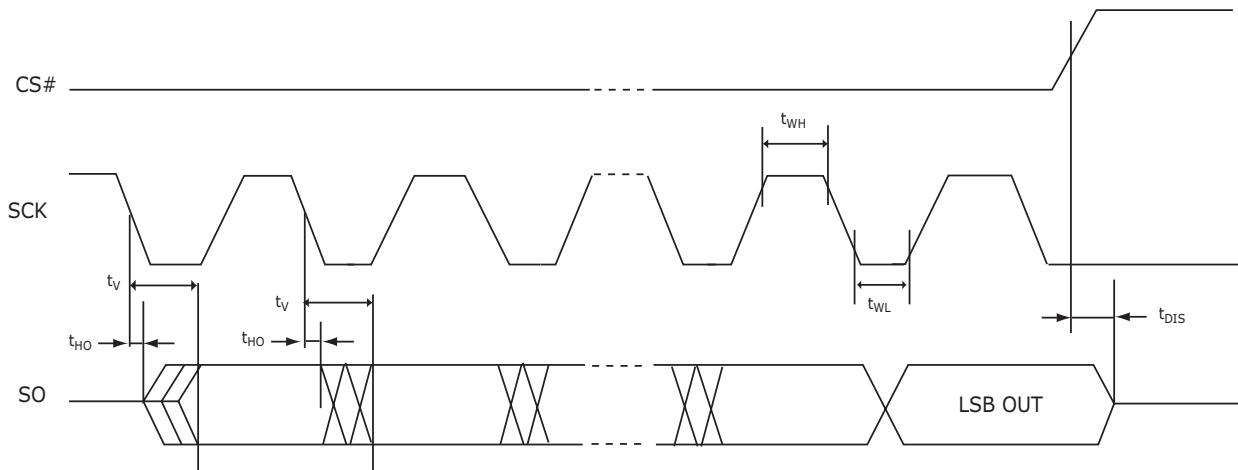

Figure 21. SPI Mode 0 (0,0) Output Timing

AC Characteristics

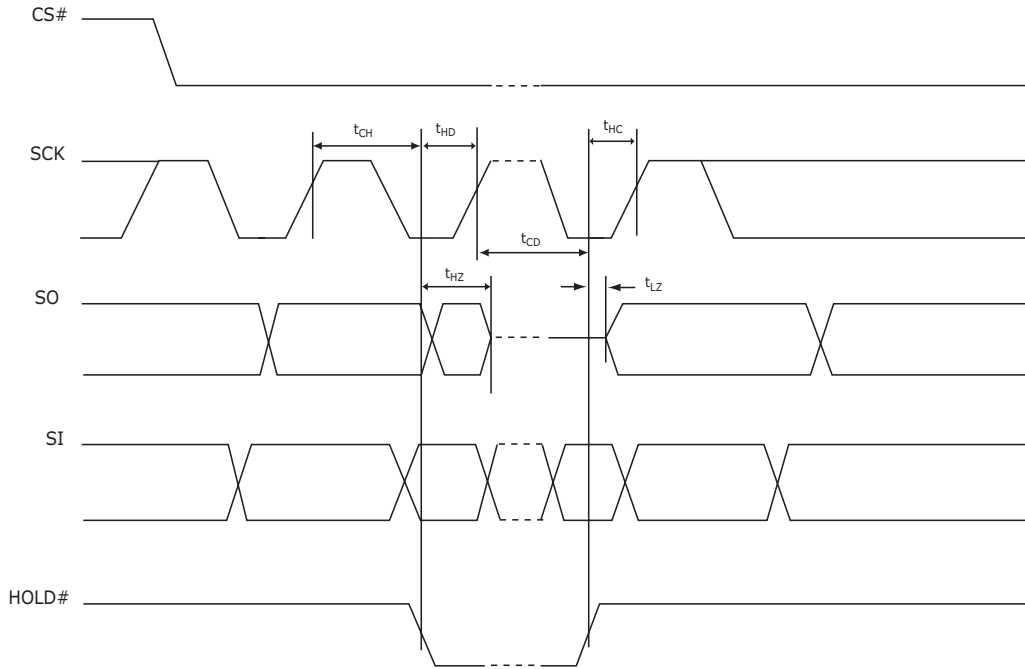

Figure 22. HOLD# Timing

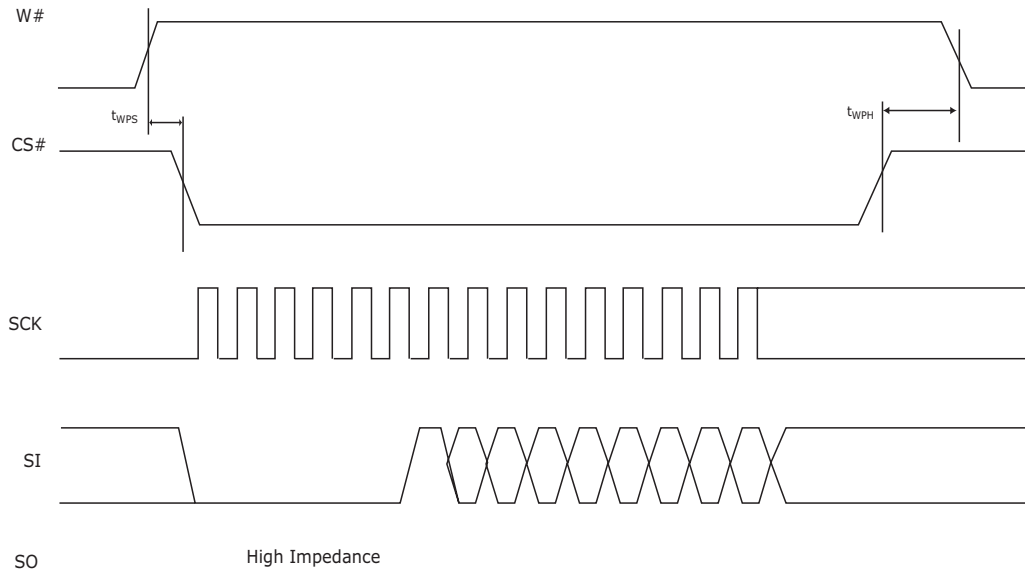
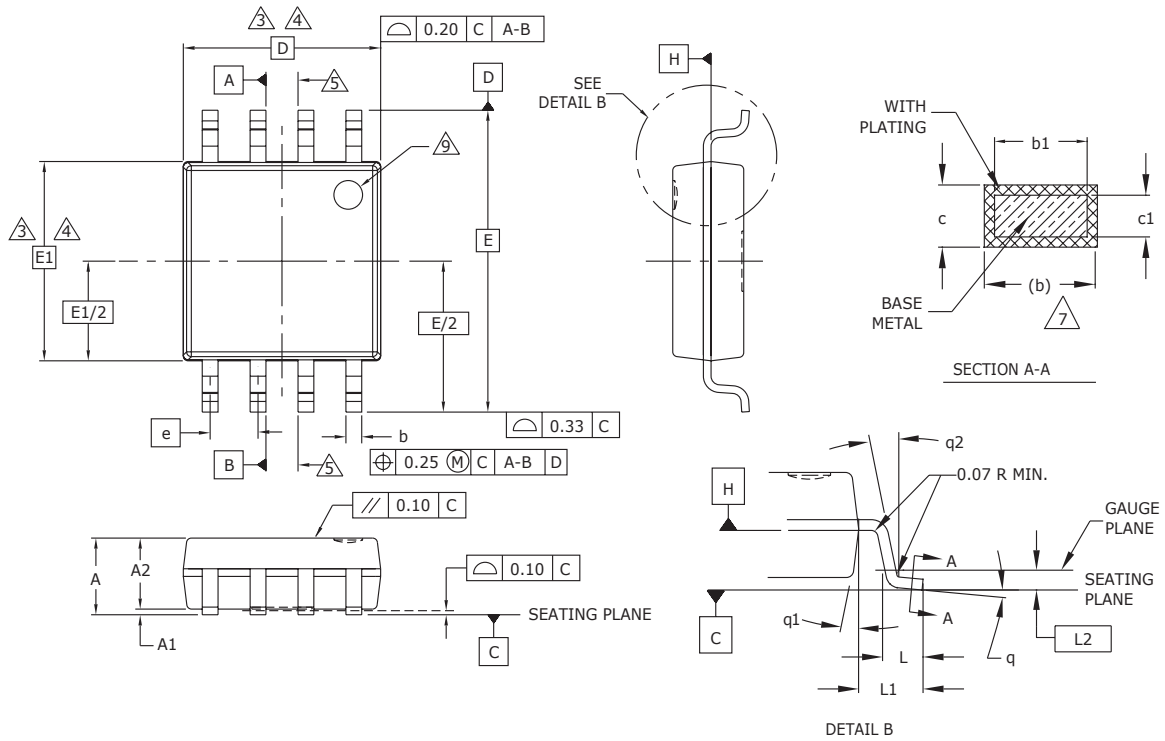

Figure 23. Write Protect Setup and Hold Timing during WRSR when SRWD=1

Physical Dimensions

S08 wide—8-pin Plastic Small Outline 208 mils Body Width Package



PACKAGE JEDEC SYMBOL	SOC 008 (inches)		SOC 008 (mm)	
	MIN	MAX	MIN	MAX
A	0.069	0.085	1.753	2.159
A1	0.002	0.0098	0.051	0.249
A2	0.067	0.075	1.70	1.91
b	0.014	0.019	0.356	0.483
b1	0.013	0.018	0.330	0.457
c	0.0075	0.0095	0.191	0.241
c1	0.006	0.008	0.152	0.203
D	0.208 BSC		5.283 BSC	
E	0.315 BSC		8.001 BSC	
E1	0.208 BSC		5.283 BSC	
e	.050 BSC		1.27 BSC	
L	0.020	0.030	0.508	0.762
L1	.055 REF		1.40 REF	
L2	.010 BSC		0.25 BSC	
N	8		8	
θ	0°	8°	0°	8°
θ1	5°	15°	5°	15°
θ2	0°		0°	

NOTES:

- ALL DIMENSIONS ARE IN BOTH INCHES AND MILLIMETERS.
- DIMENSIONING AND TOLERANCING PER ASME Y14.5M - 1994.
- ⚠ DIMENSION D DOES NOT INCLUDE MOLD FLASH, PROTRUSIONS OR GATE BURRS. MOLD FLASH, PROTRUSIONS OR GATE BURRS SHALL NOT EXCEED 0.15 mm PER END. DIMENSION E1 DOES NOT INCLUDE INTERLEAD FLASH OR PROTRUSION INTERLEAD FLASH OR PROTRUSION SHALL NOT EXCEED 0.25 mm PER SIDE. D AND E1 DIMENSIONS ARE DETERMINED AT DATUM H.
- ⚠ THE PACKAGE TOP MAY BE SMALLER THAN THE PACKAGE BOTTOM. DIMENSIONS D AND E1 ARE DETERMINED AT THE OUTMOST EXTREMES OF THE PLASTIC BODY EXCLUSIVE OF MOLD FLASH, TIE BAR BURRS, GATE BURRS AND INTERLEAD FLASH. BUT INCLUDING ANY MISMATCH BETWEEN THE TOP AND BOTTOM OF THE PLASTIC BODY.
- ⚠ DATUMS A AND B TO BE DETERMINED AT DATUM H.
- "N" IS THE MAXIMUM NUMBER OF TERMINAL POSITIONS FOR THE SPECIFIED PACKAGE LENGTH.
- ⚠ THE DIMENSIONS APPLY TO THE FLAT SECTION OF THE LEAD BETWEEN 0.10 TO 0.25 mm FROM THE LEAD TIP.
- ⚠ DIMENSION "b" DOES NOT INCLUDE DAMBAR PROTRUSION. ALLOWABLE DAMBAR PROTRUSION SHALL BE 0.10 mm TOTAL IN EXCESS OF THE "b" DIMENSION AT MAXIMUM MATERIAL CONDITION. THE DAMBAR CANNOT BE LOCATED ON THE LOWER RADIUS OF THE LEAD FOOT.
- ⚠ THIS CHAMFER FEATURE IS OPTIONAL. IF IT IS NOT PRESENT, THEN A PIN 1 IDENTIFIER MUST BE LOCATED WITHIN THE INDEX AREA INDICATED.
- LEAD COPLANARITY SHALL BE WITHIN 0.10 mm AS MEASURED FROM THE SEATING PLANE.

3432 \ 16-038.03 \ 10.28.04

Physical Dimensions

USON 8L (5x6mm) No-Lead Package

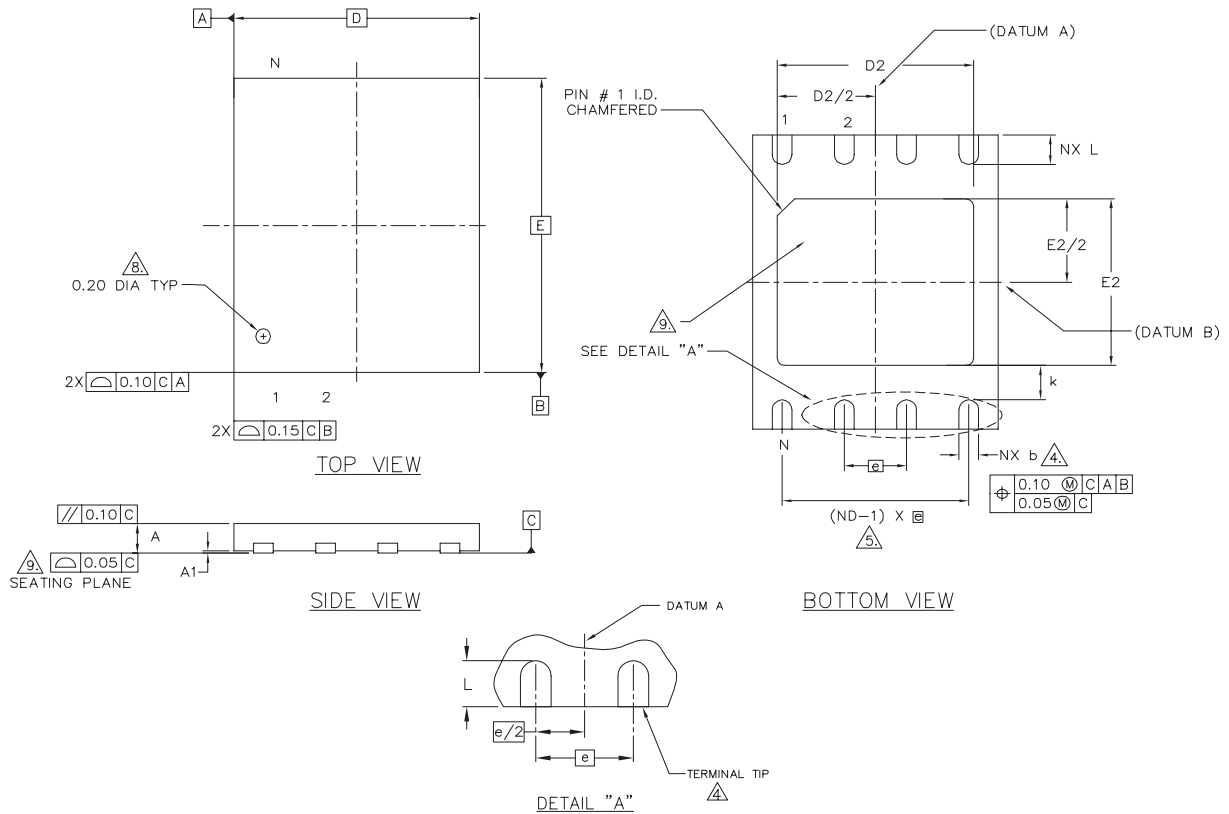

QUAD FLAT NO LEAD PACKAGES (UNE) - PLASTIC				
SYMBOL	DIMENSIONS			NOTE
	MIN	NOM	MAX	
e	1.27 BSC			
N	8			3
ND	4			5
L	0.55	0.60	0.65	
b	0.35	0.40	0.45	4
D2	3.90	4.00	4.10	
E2	3.30	3.40	3.50	
D	5.00 BSC			
E	6.00 BSC			
A	0.45	0.50	0.55	
A1	0.00	0.02	0.05	
K	0.20 MAX.			
θ	0	---	12	2

NOTES:

1. DIMENSIONING AND TOLERANCING CONFORMS TO ASME Y14.5M-1994.
2. ALL DIMENSIONS ARE IN MILLIMETERS, 0 IS IN DEGREES.
3. N IS THE TOTAL NUMBER OF TERMINALS.
4. DIMENSION b APPLIES TO METALLIZED TERMINAL AND IS MEASURED BETWEEN 0.15 AND 0.30 mm FROM TERMINAL TIP. IF THE TERMINAL HAS THE OPTIONAL RADIUS ON THE OTHER END OF THE TERMINAL, THE DIMENSION b SHOULD NOT BE MEASURED IN THAT RADIUS AREA.
5. ND REFERS TOT HE NUMBER OF TERMINALS ON D SIDE.
6. MAXIMUM PACKAGE WARPAGE IS 0.05 mm.
7. MAXIMUM ALLOWABLE BURRS IS 0.076 mm IN ALL DIRECTIONS.
8. PIN #1 ID ON TOP WILL BE LASER MARKED.
9. BILATERAL COPLANARITY ZONE APPLIES TO THE EXPOSED HEAT SINK SLUG AS WELL AS THE TERMINALS.

Revision Summary

Revision A0 (March 1, 2005)

Initial Release.

Revision A1 (March 28, 2005)

Updated Table 7.

Removed Commercial Temperature Range.

Changed *WSON* package nomenclature to *USON* package; updated *USON* package dimensions.

Added Tray option for Packing Type.

Colophon

The products described in this document are designed, developed and manufactured as contemplated for general use, including without limitation, ordinary industrial use, general office use, personal use, and household use, but are not designed, developed and manufactured as contemplated (1) for any use that includes fatal risks or dangers that, unless extremely high safety is secured, could have a serious effect to the public, and could lead directly to death, personal injury, severe physical damage or other loss (i.e., nuclear reaction control in nuclear facility, aircraft flight control, air traffic control, mass transport control, medical life support system, missile launch control in weapon system), or (2) for any use where chance of failure is intolerable (i.e., submersible repeater and artificial satellite). Please note that Spansion will not be liable to you and/or any third party for any claims or damages arising in connection with above-mentioned uses of the products. Any semiconductor devices have an inherent chance of failure. You must protect against injury, damage or loss from such failures by incorporating safety design measures into your facility and equipment such as redundancy, fire protection, and prevention of over-current levels and other abnormal operating conditions. If any products described in this document represent goods or technologies subject to certain restrictions on export under the Foreign Exchange and Foreign Trade Law of Japan, the US Export Administration Regulations or the applicable laws of any other country, the prior authorization by the respective government entity will be required for export of those products.

Trademarks and Notice

The contents of this document are subject to change without notice. This document may contain information on a Spansion LLC product under development by Spansion LLC. Spansion LLC reserves the right to change or discontinue work on any product without notice. The information in this document is provided as is without warranty or guarantee of any kind as to its accuracy, completeness, operability, fitness for particular purpose, merchantability, non-infringement of third-party rights, or any other warranty, express, implied, or statutory. Spansion LLC assumes no liability for any damages of any kind arising out of the use of the information in this document.

Copyright ©2004-2005 Spansion LLC. All rights reserved. Spansion, the Spansion logo, and MirrorBit are trademarks of Spansion LLC. Other company and product names used in this publication are for identification purposes only and may be trademarks of their respective companies.