

Multi-Output Clock Generator

Features

- Generates multiple clock outputs from an inexpensive 27MHz crystal .
- Frequency outputs:
 - 27MHz Reference clock
 - 27MHz Reference clock
 - 10MHz
 - 24MHz
 - 28.322MHz
 - 24.576MHz
- Operates with a $3.3V \pm 5\%V$ Supply Voltage
- Packaged in 16 pin TSSOP
- Available in Commercial Temperature range
- Advanced, low-power CMOS process.

Product Description

The PCS1P2858A is a versatile multi output clock generator. The PCS1P2858A uses the latest PLL technology. The six Clock outputs are generated using an inexpensive 27MHz Crystal. The accuracy of the 27MHz Input Clock should be within $\pm 50\text{ppm}$. The outputs consist of 24.576MHz, 24 MHz, 10MHz, and 28.322 MHz clocks together with two 27 MHz reference clock. The OE tri-states all the clocks when disabled. The device operates from a Supply Voltage of $3.3V \pm 5\%V$. The device is available in a 16-pin TSSOP JEDEC package.

Application

PCS1P2858A is targeted for use in HDTV digital video

Block Diagram

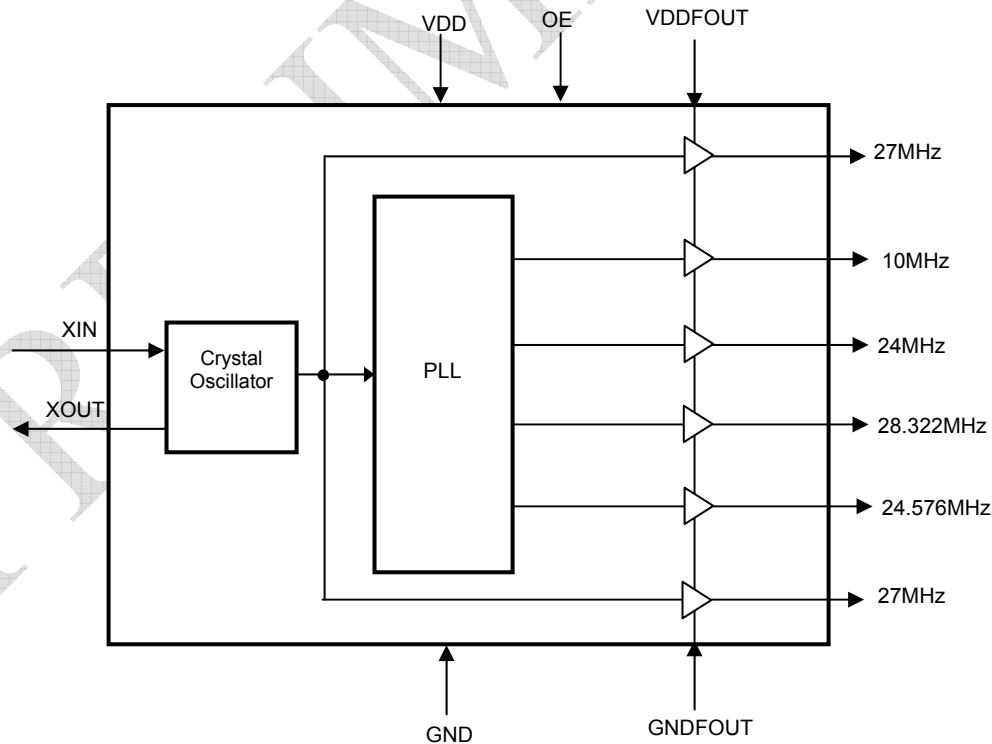

rev 0.1

Pin Assignment

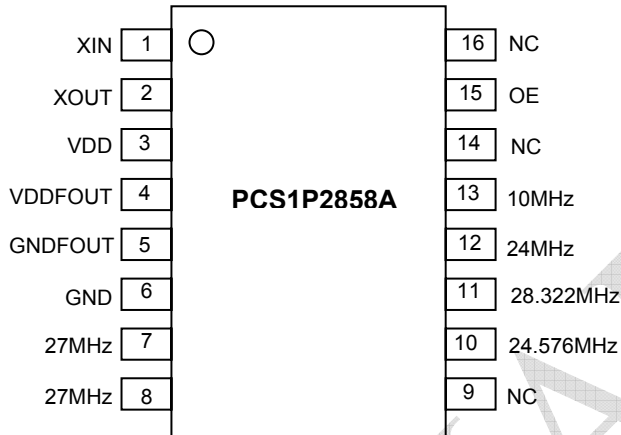

Pin Description

Pin #	Pin Name	Pin Type	Pin Description
1	XIN	Input	Crystal connection or external reference frequency input. It can be connected to a 27MHz Fundamental mode crystal
2	XOUT	Output	Connection to crystal. If using an external reference clock, this pin must be left unconnected.
3	VDD	Power	Connect to +3.3V.
4	VDDFOUT	Power	
5	GNDFOUT	Power	Connect to ground.
6	GND	Power	Connect to ground.
7	27MHz	Output	27MHz Reference Clock output
8	27MHz	Output	27MHz Reference Clock output
9	NC	-	No connection
10	24.576MHz	Output	24.576MHz Output Clock
11	28.322MHz	Output	28.322MHz Output Clock
12	24MHz	Output	24MHz Output Clock
13	10MHz	Output	10MHz Output Clock
14	NC	-	No connection
15	OE	Input	Output Enable bit. When this pin is made HIGH, the output clocks are enabled. Tri-states all the clocks when disabled. Has an Internal pull-up resistor
16	NC	-	No connection

rev 0.1

Absolute Maximum Ratings

Symbol	Parameter	Rating	Unit
VDD	Power Supply Voltage relative to Ground	-0.5 to +4.6	V
V _{IN}	Input Voltage relative to Ground (Input Pins)	-0.5 to VDD+0.3	
T _{STG}	Storage temperature	-65 to +150	°C
T _A	Operating temperature	0 to +70	°C
T _s	Max. Soldering Temperature (10 sec)	260	°C
T _J	Junction Temperature	125	°C
T _{DV}	Static Discharge Voltage (As per JEDEC STD22- A114-B)	2	KV

Note: These are stress ratings only and are not implied for functional use. Exposure to absolute maximum ratings for prolonged periods of time may affect device reliability.

DC Electrical Characteristics

Parameter	Symbol	Conditions	Min	Typ	Max	Units
Operating Voltage	VDD		3.135	3.3	3.465	V
Supply Current	I _{DD}	No Load, Clocks on		TBD		mA
Input High Voltage	V _{IH}		2		VDD+0.3	V
Input Low Voltage	V _{IL}		GND-0.3		0.8	V
Output High Voltage	V _{OH}	I _{OH} = -4mA	VDD-0.4		-	V
Output High Voltage	V _{OH}	I _{OH} = -12mA	2.4		-	V
Output Low Voltage	V _{OL}	I _{OL} = 12mA	-		0.4	V
Short Circuit Current	I _{OS}	Clock outputs	-	±70	-	mA
Input Capacitance	C _{IN}	Inputs	-	5	-	pF
Nominal output impedance	Z _{OUT}		-	20	-	Ω

rev 0.1

AC Electrical Characteristics

Symbol	Parameter	Min	Typ	Max	Unit	
CLKIN	Input frequency	-	27	-	MHz	
CLK OUT	Output frequency	-	27	-	MHz	
		-	10	-	MHz	
		-	24	-	MHz	
		-	24.576	-	MHz	
		-	28.322	-	MHz	
t_{LH}^*	Output rise time (Measured from 0.8V to 2.0V)	0.8	1.4	2.0	nS	
t_{HL}^*	Output fall time (Measured from 2.0V to 0.8V)	0.8	1.4	2.0	nS	
t_{JC}^*	Jitter (Cycle to cycle)	-	TBD	-	pS	
	Synthesis Error (Output Frequency)	28.322MHz	-	5.68	-	ppm
		Other outputs	-	0	-	ppm
t_D^*	Output duty cycle	40	50	60	%	
t_{ON}	Power up Time (first locked cycle after power-up)	-	3	5	mS	

* t_{LH} and t_{HL} are measured into a capacitive load of 15pF

Typical Crystal Oscillator Circuit

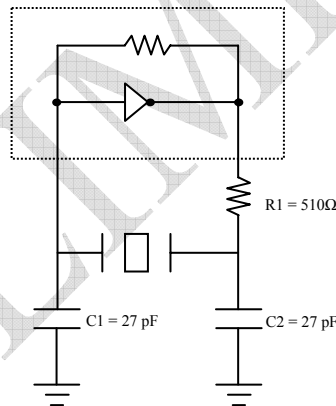

Typical Crystal Specifications

Fundamental AT cut parallel resonant crystal	
Nominal frequency	27MHz
Frequency tolerance	± 50 ppm or better at 25°C
Operating temperature range	-25°C to +85°C
Storage temperature	-40°C to +85°C
Load capacitance	18pF
Shunt capacitance	7pF maximum
ESR	25Ω

Package Information

16-lead Thin Shrunken Small Outline Package (4.40-MM Body)

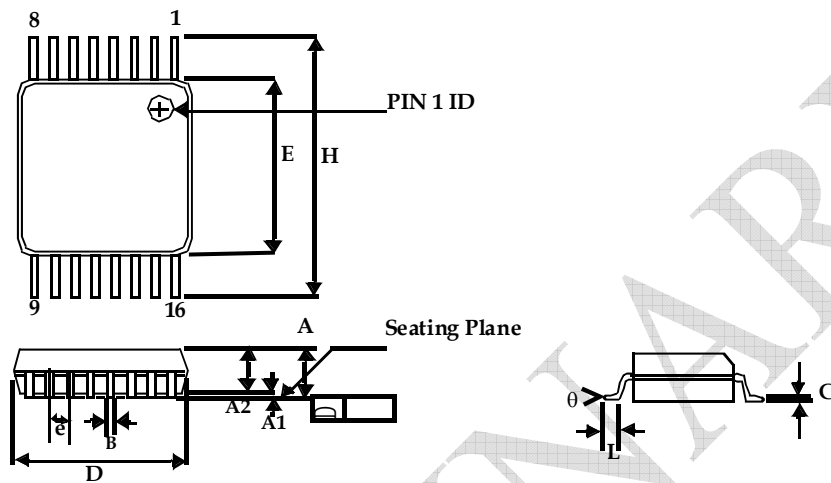

Symbol	Dimensions			
	Inches		Millimeters	
	Min	Max	Min	Max
A		0.043		1.20
A1	0.002	0.006	0.05	0.15
A2	0.031	0.041	0.80	1.05
B	0.007	0.012	0.19	0.30
C	0.004	0.008	0.09	0.20
D	0.193	0.201	4.90	5.10
E	0.169	0.177	4.30	4.50
e	0.026 BSC		0.65 BSC	
H	0.252 BSC		6.40 BSC	
L	0.020	0.030	0.50	0.75
θ	0°	8°	0°	8°

rev 0.1

Ordering Information

Part Number	Marking	Package	Temperature
PCS1P2858AG-16TR	3P2858AG	16-Pin TSSOP, TAPE & REEL, Green	Commercial
PCS1P2858AG-16TT	3P2858AG	16-Pin TSSOP, TUBE, Green	Commercial

Device Ordering Information

PCS1P2858AG-16-TR

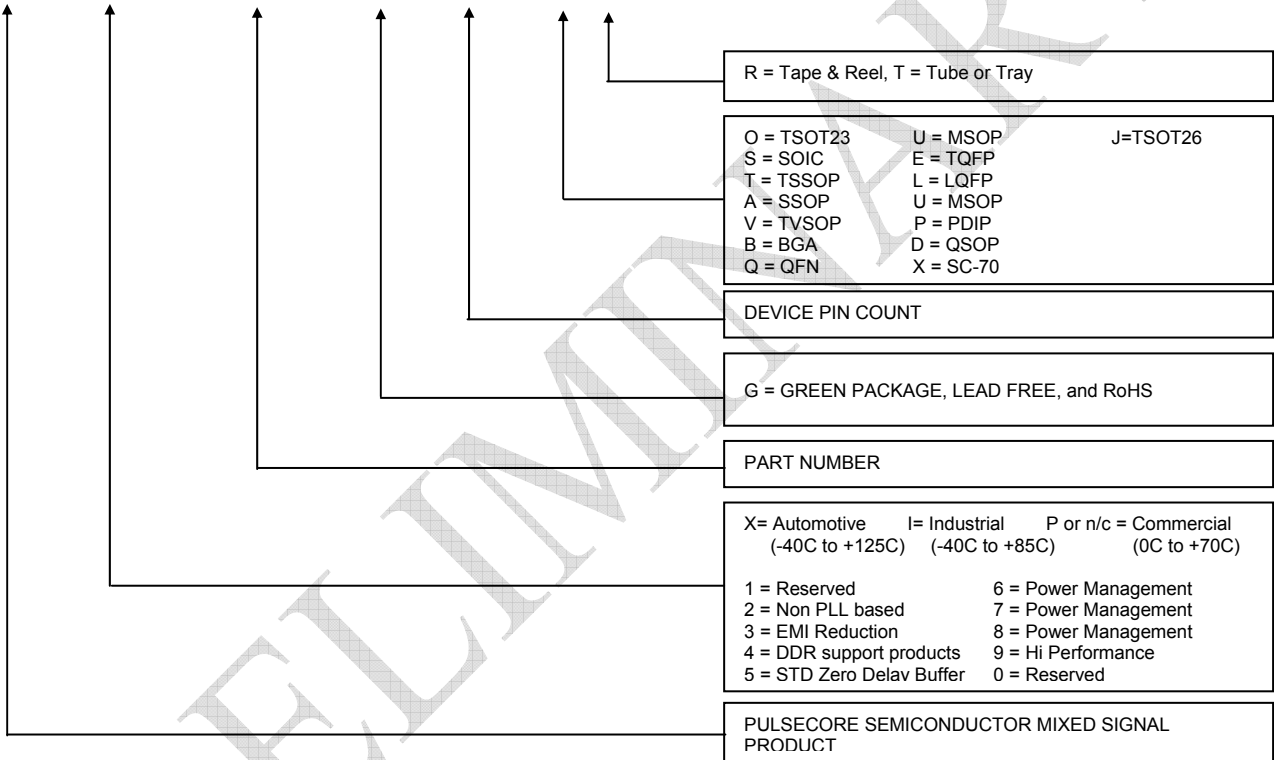

Licensed under US patent Nos 5,488,627 and 5,631,920.



PulseCore Semiconductor Corporation
1715 S. Bascom Ave Suite 200
Campbell, CA 95008
Tel: 408-879-9077
Fax: 408-879-9018
www.pulsecoresemi.com

Copyright © Alliance Semiconductor
All Rights Reserved
Part Numbers: PCS1P2858A
Document Version: 0.1

Note: This product utilizes US Patent # 6,646,463 Impedance Emulator Patent issued to PulseCore semiconductor, dated 11-11-2003

© Copyright 2006 PulseCore Semiconductor Corporation. All rights reserved. Our logo and name are trademarks or registered trademarks of PulseCore Semiconductor. All other brand and product names may be the trademarks of their respective companies. PulseCore reserves the right to make changes to this document and its products at any time without notice. PulseCore assumes no responsibility for any errors that may appear in this document. The data contained herein represents PulseCore's best data and/or estimates at the time of issuance. PulseCore reserves the right to change or correct this data at any time, without notice. If the product described herein is under development, significant changes to these specifications are possible. The information in this product data sheet is intended to be general descriptive information for potential customers and users, and is not intended to operate as, or provide, any guarantee or warranty to any user or customer. PulseCore does not assume any responsibility or liability arising out of the application or use of any product described herein, and disclaims any express or implied warranties related to the sale and/or use of PulseCore products including liability or warranties related to fitness for a particular purpose, merchantability, or infringement of any intellectual property rights, except as expressly agreed to in PulseCore's Terms and Conditions of Sale (which are available from PulseCore). All sales of PulseCore products are made exclusively according to PulseCore's Terms and Conditions of Sale. The purchase of products from PulseCore does not convey a license under any patent rights, copyrights; mask works rights, trademarks, or any other intellectual property rights of PulseCore or third parties. PulseCore does not authorize its products for use as critical components in life-supporting systems where a malfunction or failure may reasonably be expected to result in significant injury to the user, and the inclusion of PulseCore products in such life-supporting systems implies that the manufacturer assumes all risk of such use and agrees to indemnify PulseCore against all claims arising from such use.