

DATA SHEET



SAA4974H Basic without ADC

Product specification
File under Integrated Circuits, IC02

1998 Apr 21

Basic without ADC**SAA4974H****CONTENTS**

1	FEATURES	7.4	Memory controller
2	GENERAL DESCRIPTION	7.4.1	WE
3	QUICK REFERENCE DATA	7.4.2	RSTW
4	ORDERING INFORMATION	7.4.3	RE
5	BLOCK DIAGRAM	7.4.4	IE2
6	PINNING INFORMATION	7.4.5	HDFL
6.1	Pinning	7.4.6	VDFL
6.2	Pin description	7.4.7	BLND
7	FUNCTIONAL DESCRIPTION	7.5	Clock and sync interfacing
7.1	Digital processing at $2f_H$ level	7.6	4 : 1 : 1 digital input interfacing
7.1.1	4 : 1 : 1 to 4 : 2 : 2 up-conversion	7.7	Test mode operation
7.1.2	DCTI	7.8	I ² C-bus control registers
7.1.3	Y-peaking	8	LIMITING VALUES
7.1.4	Y-delay	9	THERMAL CHARACTERISTICS
7.1.5	Sidepanels and blanking	10	CHARACTERISTICS
7.2	Digital-to-analog conversion	11	APPLICATION
7.3	Microprocessor	12	PACKAGE OUTLINE
7.3.1	I ² C-bus	13	SOLDERING
7.3.2	SNERT-bus	13.1	Introduction
7.3.3	I/O-ports	13.2	Reflow soldering
7.3.4	Watchdog timer	13.3	Wave soldering
		13.4	Repairing soldered joints
		14	DEFINITIONS
		15	LIFE SUPPORT APPLICATIONS
		16	PURCHASE OF PHILIPS I ² C COMPONENTS

Basic without ADC

SAA4974H

1 FEATURES

- Field rate up-conversion (50 to 100 Hz or 60 to 120 Hz)
- 4 : 1 : 1 digital input
- Digital Colour Transient Improvement (DCTI)
- Digital luminance peaking
- Triple 10-bit Digital-to-Analog Converter (DAC)
- Memory controller
- Embedded microprocessor
- 16 kbyte ROM
- 256 byte RAM
- I²C-bus interface
- Synchronous No parity Eight bit Reception and Transmission (SNERT) interface.

**2 GENERAL DESCRIPTION**

The SAA4974H is a video processing IC providing a digital YUV 4 : 1 : 1 input interface, analog YUV output, video enhancing features, memory controlling and an embedded 80C51 microprocessor core. It is applicable especially for field rate up-conversion (50 to 100 Hz or 60 to 120 Hz) in cooperation with a 2.9 Mbit field memory. It is designed for applications together with:

- SAA7111A, VPC3200 (video decoder)
- SAA4955/56TJ, TMS4C2972/73 (serial field memories)
- SAA4990H (PROZONIC)
- SAA4991WP (MELZONIC).

3 QUICK REFERENCE DATA

SYMBOL	PARAMETER	MIN.	TYP.	MAX.	UNIT
V _{DDA(1,2)}	analog supply voltage	3.15	3.3	3.45	V
V _{DDD(1,2,3)}	digital supply voltage	3.0	3.3	3.6	V
V _{DDIO(1,2,3)}	I/O supply voltage	4.5	5.0	5.5	V
I _{DDA(1,2)}	analog supply current	–	25	40	mA
I _{DDD(1,2,3)}	digital supply current	–	50	70	mA
I _{DDIO(1,2,3)}	I/O supply current	–	10	20	mA
P _{tot}	total power dissipation	–	–	0.5	W
T _{amb}	operating ambient temperature	–20	–	+70	°C

4 ORDERING INFORMATION

TYPE NUMBER	PACKAGE		
	NAME	DESCRIPTION	VERSION
SAA4974H	QFP80	plastic quad flat package; 80 leads (lead length 1.95 mm); body 14 × 20 × 2.8 mm	SOT318-2

Basic without ADC

SAA4974H

5 BLOCK DIAGRAM

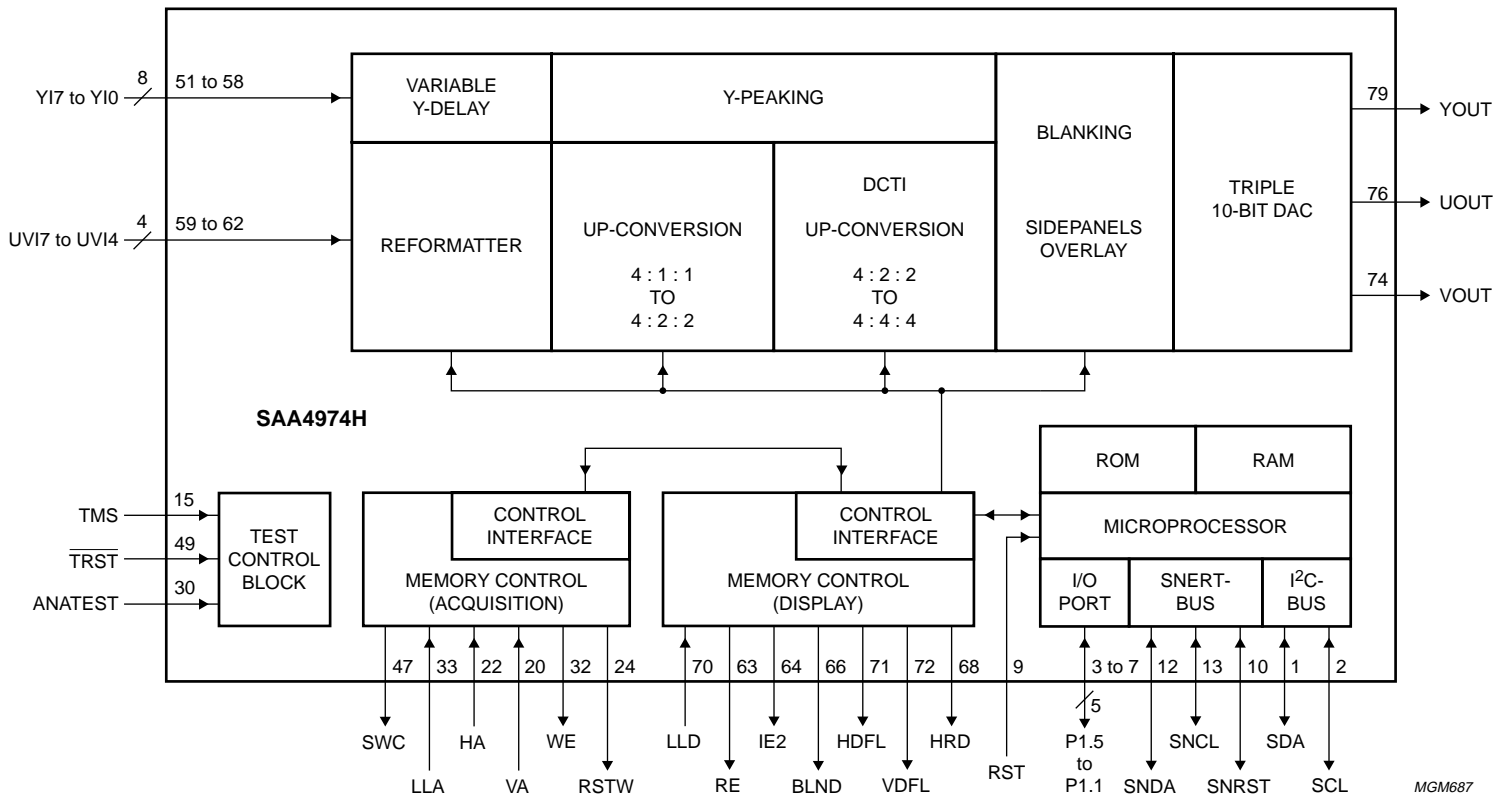

MGM687

Fig.1 Block diagram.

Basic without ADC

SAA4974H

6 PINNING INFORMATION

6.1 Pinning

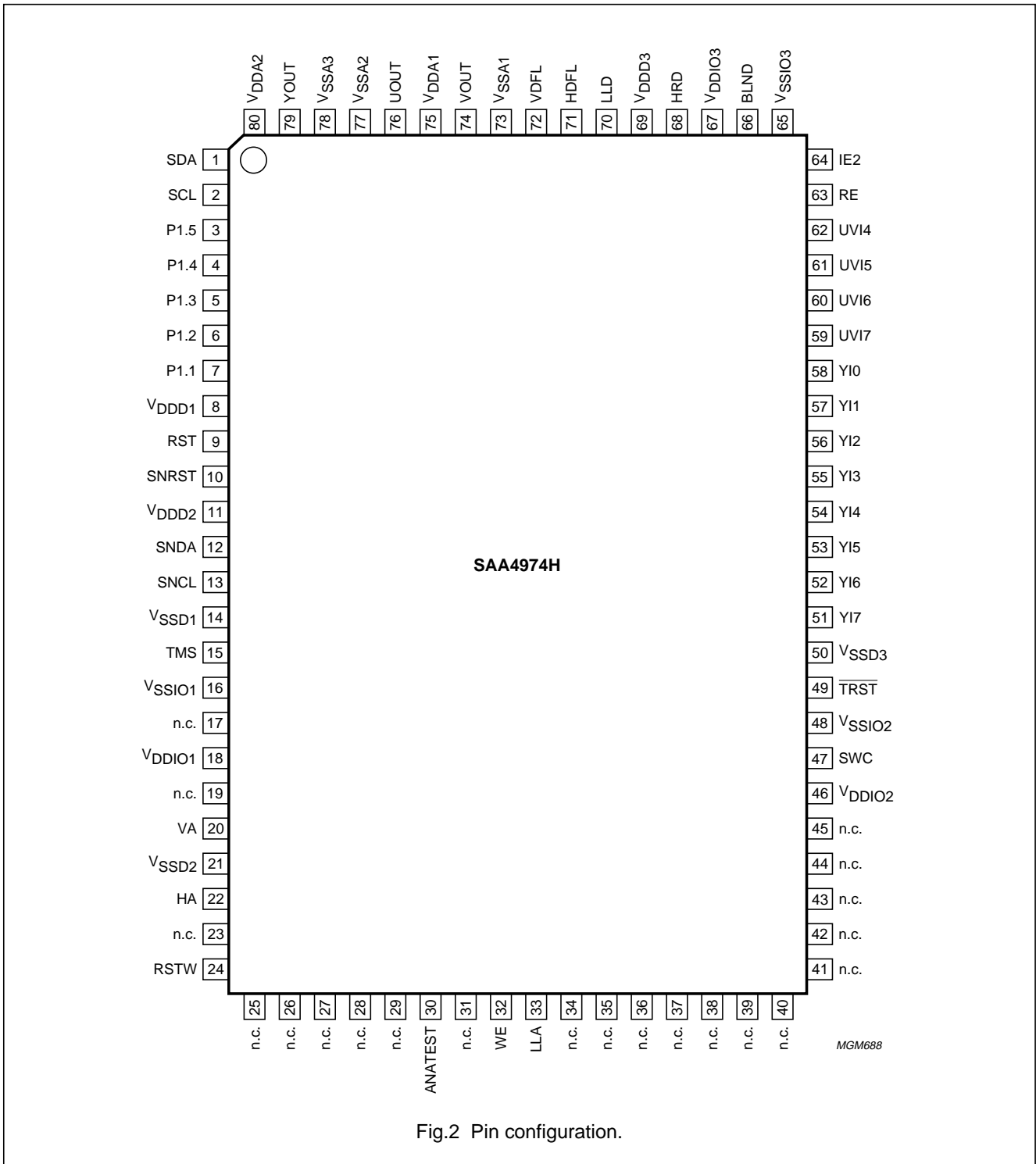

Fig.2 Pin configuration.

Basic without ADC

SAA4974H

6.2 Pin description

Table 1 SOT318-2 package

SYMBOL	PIN	DESCRIPTION
SDA	1	I ² C-bus serial data (P 1.7)
SCL	2	I ² C-bus serial clock (P 1.6)
P1.5	3	Port 1 data input/output signal 5
P1.4	4	Port 1 data input/output signal 4
P1.3	5	Port 1 data input/output signal 3
P1.2	6	Port 1 data input/output signal 2
P1.1	7	Port 1 data input/output signal 1
V _{DD1}	8	digital supply voltage 1 (3.3 V)
RST	9	microprocessor reset input
SNRST	10	SNERT restart (port 1.0)
V _{DD2}	11	digital supply voltage 2 (3.3 V)
SNDA	12	SNERT data
SNCL	13	SNERT clock
V _{SS1}	14	digital ground 1
TMS	15	test mode select
V _{SSIO1}	16	I/O ground 1
n.c.	17	not connected
V _{DDIO1}	18	I/O supply voltage 1 (5 V)
n.c.	19	not connected
VA	20	vertical synchronization input, acquisition part
V _{SS2}	21	digital ground 2
HA	22	digital horizontal reference input
n.c.	23	not connected
RSTW	24	reset write signal output, memory 1
n.c.	25	not connected
n.c.	26	not connected
n.c.	27	not connected
n.c.	28	not connected
n.c.	29	not connected
ANATEST	30	analog test input
n.c.	31	not connected
WE	32	write enable signal output, memory 1
LLA	33	acquisition clock input
n.c.	34	not connected
n.c.	35	not connected
n.c.	36	not connected
n.c.	37	not connected
n.c.	38	not connected

Basic without ADC

SAA4974H

SYMBOL	PIN	DESCRIPTION
n.c.	39	not connected
n.c.	40	not connected
n.c.	41	not connected
n.c.	42	not connected
n.c.	43	not connected
n.c.	44	not connected
n.c.	45	not connected
V _{DDIO2}	46	I/O supply voltage 2 (5 V)
SWC	47	serial write clock output
V _{SSIO2}	48	I/O ground 2
$\overline{\text{TRST}}$	49	test reset, LOW active
V _{SSD3}	50	digital ground 3
YI7	51	Y digital input bit 7 (MSB)
YI6	52	Y digital input bit 6
YI5	53	Y digital input bit 5
YI4	54	Y digital input bit 4
YI3	55	Y digital input bit 3
YI2	56	Y digital input bit 2
YI1	57	Y digital input bit 1
YI0	58	Y digital input bit 0
UVI7	59	U digital input bit 1
UVI6	60	U digital input bit 0
UVI5	61	V digital input bit 1
UVI4	62	V digital input bit 0
RE	63	read enable signal output, memory 1
IE2	64	input enable signal output, memory 2
V _{SSIO3}	65	I/O ground 3
BLND	66	horizontal blanking signal output, display part
V _{DDIO3}	67	I/O supply voltage 3 (5 V)
HRD	68	horizontal reference signal output, deflection part
V _{DDD3}	69	digital supply voltage 3 (3.3 V)
LLD	70	display clock input
HDFL	71	horizontal synchronization signal output, deflection part
VDFL	72	vertical synchronization signal output, deflection part
V _{SSA1}	73	analog ground 1
VOUT	74	V analog output
V _{DDA1}	75	analog supply voltage 1 (3.3 V)
UOUT	76	U analog output
V _{SSA2}	77	analog ground 2

Basic without ADC

SAA4974H

SYMBOL	PIN	DESCRIPTION
V _{SSA3}	78	analog ground 3
YOUT	79	Y analog output
V _{DDA2}	80	analog supply voltage 2 (3.3 V)

7 FUNCTIONAL DESCRIPTION

7.1 Digital processing at 2f_H level

7.1.1 4 : 1 : 1 TO 4 : 2 : 2 UP-CONVERSION

An up-converter to 4 : 2 : 2 is applied with a linear interpolation filter for creation of the extra samples. These are combined with the original samples from the 4 : 1 : 1 stream.

7.1.2 DCTI

The Digital Colour Transient Improvement (DCTI) is intended for U and V signals originating from a 4 : 1 : 1 source. Horizontal transients are detected and enhanced without overshoots by differentiating, make absolute and again differentiating the U and V signals separately. This results in a 4 : 4 : 4 U and V bandwidth. To prevent third harmonic distortion, typical for this processing, a so called over the hill protection prevents peak signals to become distorted.

Via I²C-bus it is possible to control: gain width (see Fig.4), threshold (i.e. immunity against noise), selection of simple or improved first differentiating filter (see Fig.3), limit for pixel shift range (see Fig.5), common or separate processing of U and V signals, hill protection mode (i.e. no discolourations in narrow colour gaps), low-pass filtering for U and V signals (see Fig.6) and a so called super hill mode, which avoids discolourations in transients within a colour component.

Basic without ADC

SAA4974H

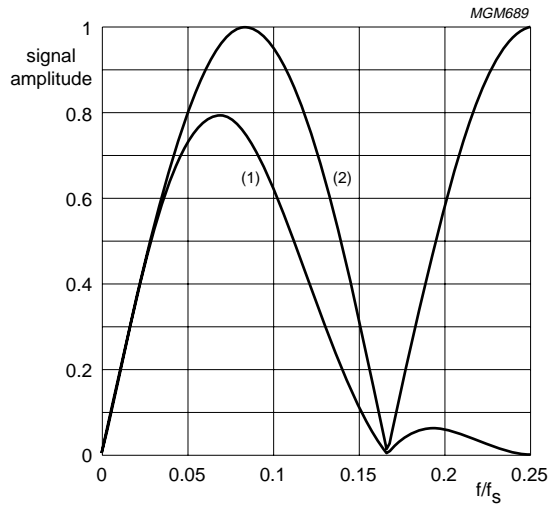

- (1) dcti_ddx_sel = 1.
- (2) dcti_ddx_sel = 0.

Fig.3 DCTI first differentiating filter; transfer function with variation of control signal dcti_ddx_sel.

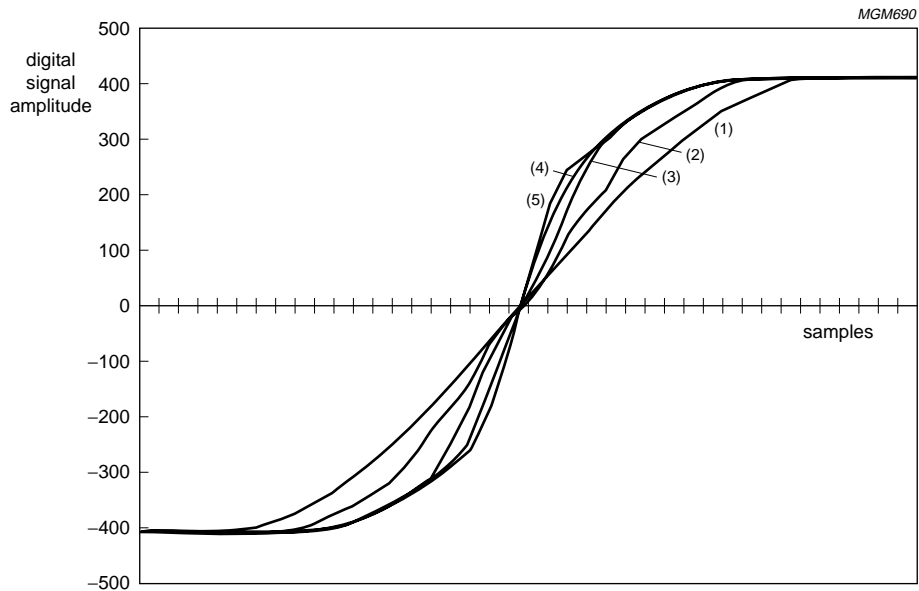

- (1) Input signal.
- (2) Gain = 1.
- (3) Gain = 3.
- (4) Gain = 5.
- (5) Gain = 7.

Fig.4 DCTI with variation of gain setting (limit = 1).

Basic without ADC

SAA4974H

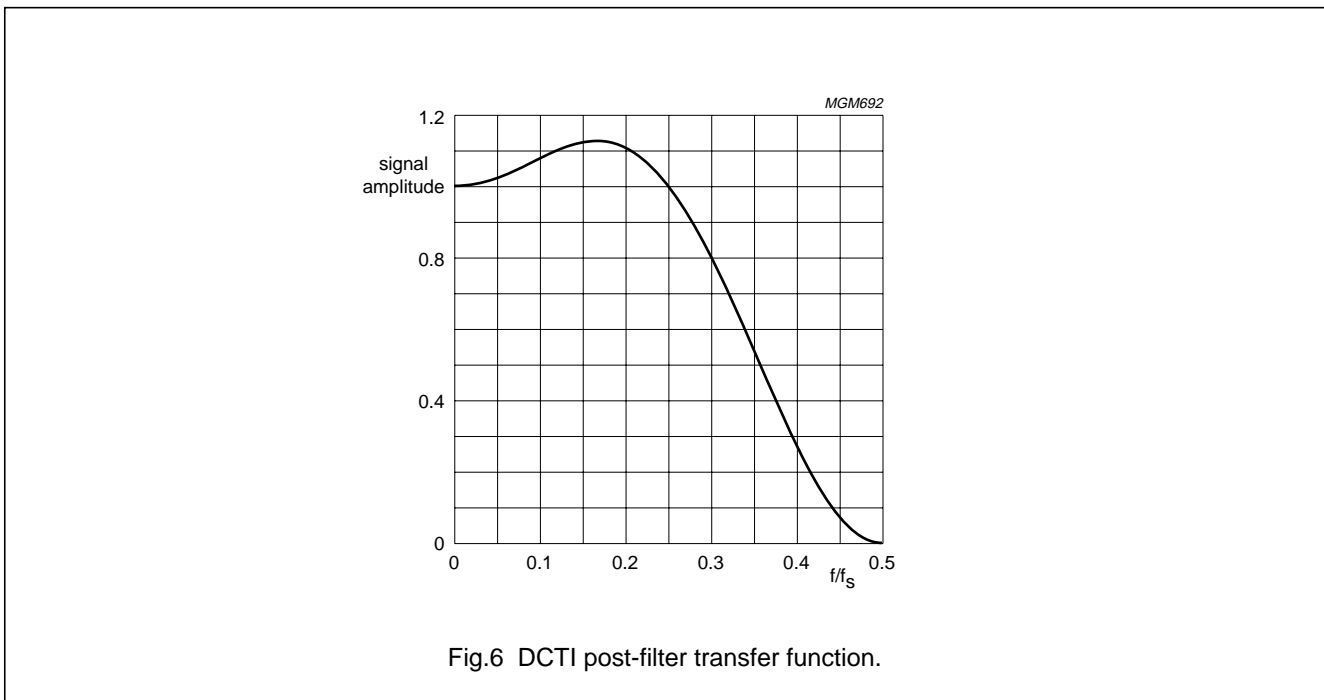
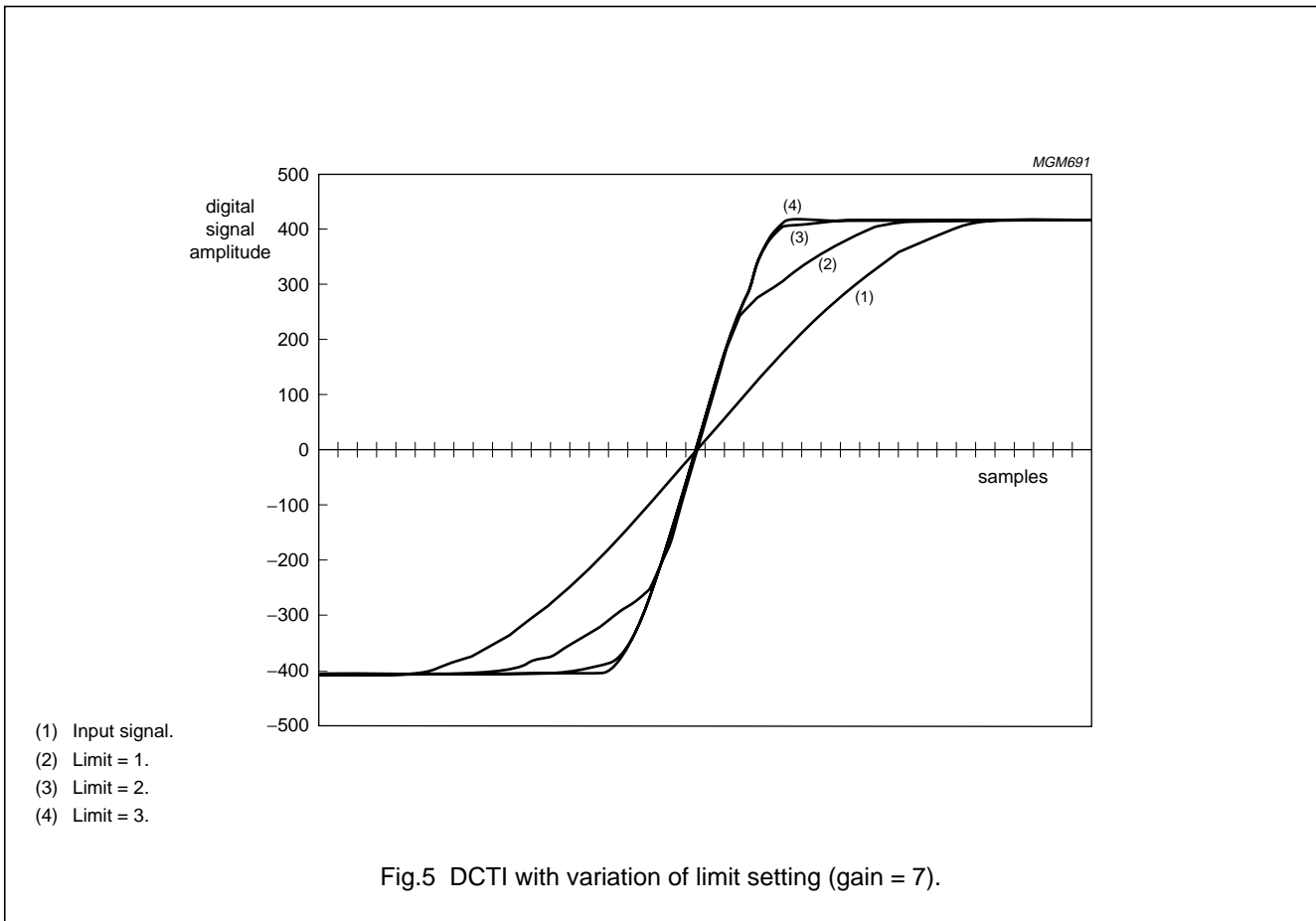

Basic without ADC

SAA4974H

7.1.3 Y-PEAKING

A linear peaking is applied, which amplifies the luminance signal in the middle and the upper ranges of the bandwidth.

The filtering is an addition of of:

- The original signal
- The original signal band-passed with centre frequency = $\frac{1}{4}f_s$
- The original signal high-passed with maximum gain at frequency = $\frac{1}{2}f_s$.

The band-passed and high-passed signals are weighted with factors 0, $\frac{1}{8}$, $\frac{1}{4}$ and $\frac{1}{2}$. The impulse response becomes $[-\alpha, -\beta, 1 + 2\alpha + 2\beta, -\beta, -\alpha]$, where α is the band-pass weighting factor and β the high-pass weighting factor.

Coring is added to obtain no gain for low amplitudes in the (high-pass + band-pass) signal, which is then considered to be noise. Coring levels can be programmed as 0 (off), +1/-2, +3/-4 and +7/-8 LSB at 8-bit word.

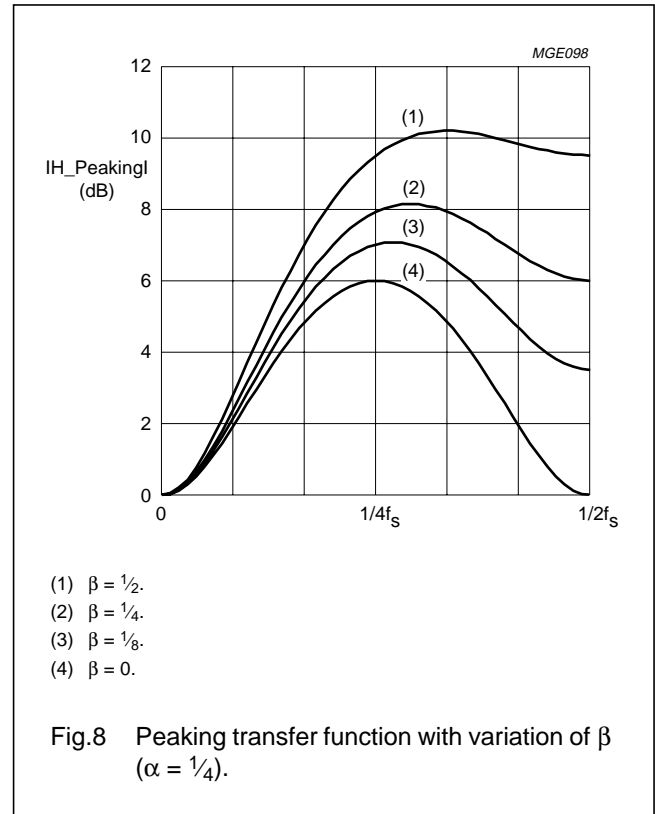
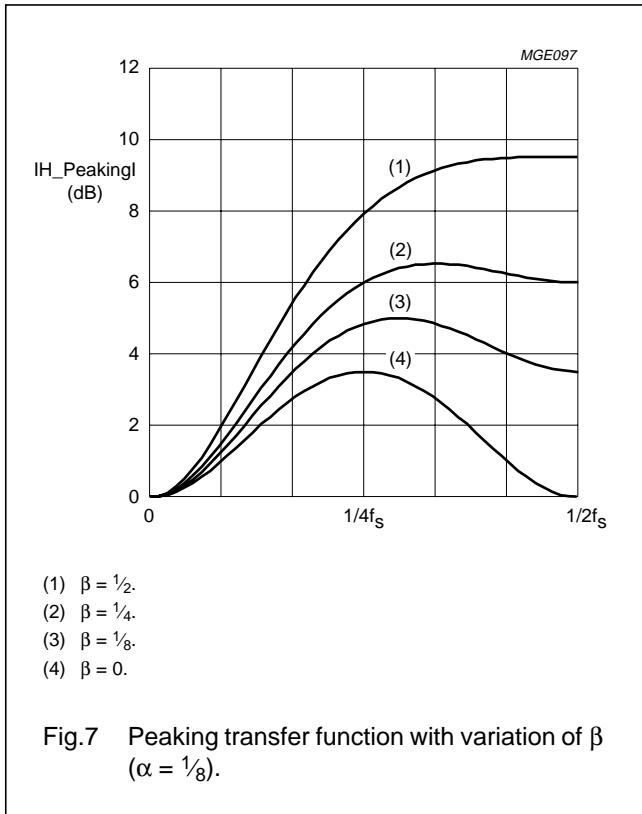

Basic without ADC

SAA4974H

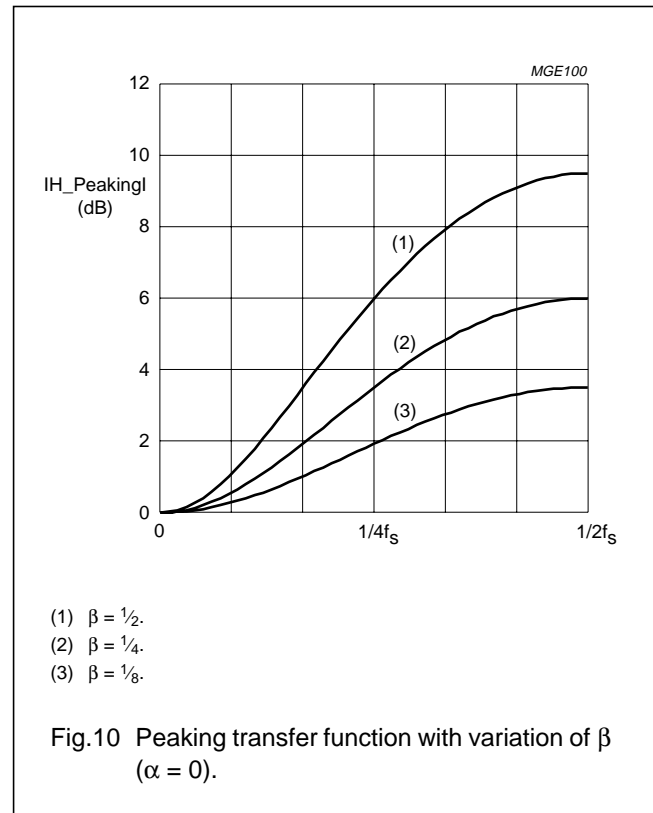
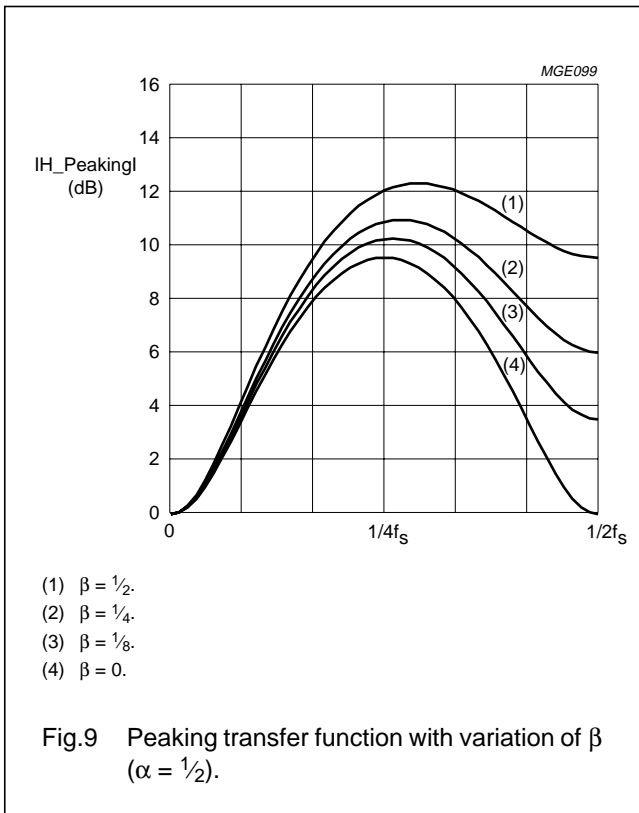

7.1.4 Y-DELAY

The Y samples can be shifted onto 8 positions with reference to the UV samples. This shift is meant to account for a possible difference in delay previous to the SAA4974H. The zero delay setting is suitable for the nominal case of aligned input data according to the interface format standard. The other settings provide one to seven samples less delay in Y.

7.1.5 SIDEPANELS AND BLANKING

Sidepanels are generated by switching Y and the 4 MSB of U and V to certain programmable values. The start and stop values for the sidepanels with reference to the rising edge of the HRD signal are programmable in a resolution of 4 LLD clock cycles. In addition a fine shift of 0 to 3 LLD clock cycles of both values can be achieved.

Blanking is done by switching Y to value 64 at 10-bit word and UV to value 0 (in twos complement). Blanking is controlled by a composite signal HVBDA, existing of a horizontal part HBDA and a vertical part VBDA. Set and reset value of the horizontal control signal HBDA are programmable with reference to the rising edge of the HRD signal, set and reset value of the vertical control

signal VBDA are programmable with reference to the rising edge of the VA signal.

The range of the Y output signal can be selected between 9 and 10 bits. In case of 9 bits for the nominal signal there is room left for under and overshoot (adding up to a total of 10 bits). In case of selecting all 10 bits of the luminance Digital-to-Analog Converter (DAC) for the nominal signal any under or overshoot will be clipped. In case of selecting 9 bits of the luminance DAC for the nominal signal under or overshoots are limited within a programmable range (see Fig.12).

7.2 Digital-to-analog conversion

Three identical 10-bit DACs are used to map the 4 : 4 : 4 data to analog levels.

7.3 Microprocessor

The SAA4974H contains an embedded 80C51 microprocessor core including 256 byte RAM and 16 kbyte ROM. The microprocessor runs on a 16 MHz clock, generated by dividing the 32 MHz display clock by a factor of 2. For controlling internal registers a host interface, consisting of a parallel address and data bus, is

Basic without ADC

SAA4974H

built in, that can be addressed as internal AUXRAM via MOVX type of instruction.

7.3.1 I²C-BUS

The I²C-bus interface in the SAA4974H is used in a slave receive and transmit mode for communication with in general a central system microprocessor.

The standardized bus frequencies of both 100 kHz and 400 kHz can be dealt with.

The I²C-bus slave address of the SAA4974H is 0 1 1 0 1 0 0 R \bar{W} .

For a detailed description of the transmission protocol refer to brochure *"I²C-bus and how to use it"* (order number 9398 393 40011) and to Application Note *"I²C-bus register specification of the SAA4974H"* (AN97042).

7.3.2 SNERT-BUS

A SNERT interface is built in, which operates in a master receive and transmit mode for communication with peripheral circuits as SAA4990H or SAA4991WP.

The SNERT interface replaces the standard UART interface. In contrary to the 8051 UART interface there are additional special function registers and there is no byte separation time between address and data.

The SNERT interface transforms the parallel data from the microprocessor into 1 Mbaud SNERT data.

The SNERT-bus consists of three signals: SNCL used as serial clock signal, generated by the SNERT interface; SNDA used as bidirectional data line, and SNRST used as reset signal, generated by the microprocessor to indicate the start of a transmission.

The read or write operation must be set by the microprocessor. In case of writing to the bus, 2 bytes are loaded by the microprocessor: one for the address, the other for the data. In case of reading from the bus, one byte is loaded by the microprocessor for the address, the received byte is the data from the addressed SNERT location.

7.3.3 I/O-PORTS

A parallel 8-bit I/O-port (P1) is available, where P1.0 is used as SNERT reset signal (SNRST), P1.1 to P1.5 can be used for application specific control signals, and P1.6 and P1.7 are used as I²C-bus signals (SCL and SDA).

7.3.4 WATCHDOG TIMER

The microprocessor contains an internal Watchdog timer, which can be activated by setting the corresponding special function register PCON.4. Only a synchronous reset will clear this bit. To prevent a system reset the watchdog timer must be reloaded in time. The Watchdog timer is incremented every 0.75 ms. The time interval between the timer's reloading and the occurrence of a reset depends on the reloaded 8-bit value.

7.4 Memory controller

The memory controller provides all necessary acquisition clock related write signals (WE and RSTW) and display clock related read signals (RE and IE2) to control one or two-field memory concepts. Furthermore the drive signals (HDFL and VDFL) for the horizontal and vertical deflection power stages are generated. Also a horizontal blanking pulse BLND is generated which can be used for peripheral circuits as SAA4990H. The memory controller is connected to the microprocessor via the host interface. Start and stop values for all pulses, referring to the corresponding horizontal or vertical reference signal, are programmable under control of the internal software. To allow an user access to these control signals via I²C-bus a range of subaddresses is reserved; for a detailed description of this user interface refer to Application Note *"I²C-bus register specification of the SAA4974H"* (AN97042).

7.4.1 WE

The write enable signal for field memory 1 is a composite signal consisting of a horizontal and a vertical part. The horizontal position with reference to the rising edge of the HA signal and the vertical position with reference to the rising edge of the VA signal are programmable.

7.4.2 RSTW

Reset write signal for field memory 1; this signal is derived from the positive edge of the VA input signal and has a pulse width of 64 μ s.

7.4.3 RE

The read enable signal for field memory 1 is a composite signal consisting of a horizontal and a vertical part. The horizontal position with reference to the rising edge of the HA signal and the vertical position with reference to the rising edge of the VA signal are programmable.

Basic without ADC

SAA4974H

7.4.4 IE2

Input enable signal for field memory 2, can be directly set or reset by the microprocessor.

7.4.5 HDFL

Horizontal deflection signal for driving an deflection circuit; this signal has a cycle time of 32 μ s and a pulse width of 76 LLD clock cycles.

7.4.6 VDFL

Vertical deflection signal for driving a deflection circuit; this signal has a cycle time of 10 ms; start and stop value with reference to the rising edge of the VA signal is programmable in steps of 16 μ s.

7.4.7 BLND

Horizontal blanking signal for peripheral circuits e.g. SAA4990H, start and stop values with reference to the rising edge of HRD are programmable.

7.5 Clock and sync interfacing

The line locked acquisition clock LLA and the line locked display clock LLD must be provided by the application. Also an acquisition clock synchronous line frequent signal must be provided by the application at pin HA. A vertical 50 or 60 Hz synchronization signal has to be applied on pin VA.

Typically the circuit operates as a two clock system, i.e. LLA has to be supplied with a 16 MHz clock and LLD with a 32 MHz clock. The circuit can also operate as a one clock system, i.e. a 32 MHz line locked display clock has to be provided to both pins LLA and LLD. In this case the internal horizontal pixel counter is reset by the rising edge of the HA input, and the corresponding control signal `en_hdsp_rst` has to be set via the I²C-bus.

A display clock synchronous line frequent signal is put out at pin HRD providing a duty factor of 50%. The rising edge of HRD is also the reference for display related control signals as BLND, RE, HDAV and HBDA.

The acquisition clock is buffered internally and put out as serial write clock (SWC) for supplying the field memory.

7.6 4 : 1 : 1 digital input interfacing

Digital input bus format

4 : 1 : 1 FORMAT				INPUT PIN
Y07	Y17	Y27	Y37	YI7
Y06	Y16	Y26	Y36	YI6
Y05	Y15	Y25	Y35	YI5
Y04	Y14	Y24	Y34	YI4
Y03	Y13	Y23	Y33	YI3
Y02	Y12	Y22	Y32	YI2
Y01	Y11	Y21	Y31	YI1
Y00	Y10	Y20	Y30	YI0
U07	U05	U03	U01	UVI7
U06	U04	U02	U00	UVI6
V07	V05	V03	V01	UVI5
V06	V04	V02	V00	UVI4

The start position, when the first phase of the 4 : 1 : 1 YUV dataword is expected on the input bus, can be defined by the internal control signal HDAV. The luminance input signal is expected in 8-bit straight binary format, whereas U and V input signals are expected in twos complement format. U and V input signals are inverted if the corresponding control bit `uv_inv` is set via the I²C-bus.

7.7 Test mode operation

The SAA4974H provides a test mode function which should be avoided to be entered by the customer. If the $\overline{\text{TRST}}$ input is driven to HIGH, different test modes can be selected by applying HIGH to the TMS input for a defined number of LLD clock cycles. Also the ANATEST input is only active during test mode operation. To exit the test mode TMS and $\overline{\text{TRST}}$ must be driven LOW.

Basic without ADC

SAA4974H

7.8 I²C-bus control registers

ADDRESS	BIT	NAME	DESCRIPTION
Subaddress 00H to 35H: reserved; note 1			
Subaddress 36H and 37H (DCTI)			
36H	0 to 2	dcti_gain	DCTI gain: 0, 1, 2, 3, 4, 5, 6 and 7
	3 to 6	dcti_threshold	DCTI threshold: 0 and 1 to 15
	7	dcti_ddx_sel	DCTI selection of first differentiating filter; see Fig.3
37H	0 and 1	dcti_limit	DCTI limit for pixel shift range: 0, 1, 2 and 3
	2	dcti_separate	DCTI separate processing of U and V signals; 0 = off and 1 = on
	3	dcti_protection	DCTI over the hill protection; 0 = off and 1 = on
	4	dcti_filteron	DCTI post-filter; 0 = off and 1 = on
	5	dcti_superhill	DCTI super hill mode; 0 = off and 1 = on
	6 and 7	–	reserved
Subaddress 3AH and 3BH (sidepanels overlay)			
3AH	0 to 3	overlay_u	sidepanels overlay U (4 MSB)
	4 to 7	overlay_v	sidepanels overlay V (4 MSB)
3BH	0 to 7	overlay_y	sidepanels overlay Y (8 MSB)
Subaddress 3CH (peaking)			
3CH	0 and 1	peak_α	peaking settings α: 0, 1/8, 1/4 and 1/2
	2 and 3	peak_β	peaking settings β: 0, 1/8, 1/4 and 1/2
	4 and 5	peak_limit	peaking limiter settings in display mode = 0: (256/767, 171/852, 86/937 and 0/1023)
	6 and 7	peak_coring	peaking coring settings: 0, +1/-2, +3/-4 and +7/-8 LSB at 8-bit word
Subaddress 3DH to 3FH (sidepanel position)			
3DH	0 to 7	sidepanel_start	sidepanel start position (8 MSB) with reference to the rising edge of HRD signal
3EH	0 to 7	sidepanel_stop	sidepanel stop position (8 MSB) with reference to the rising edge of HRD signal
3FH	0 and 1	sidepanel_fdel	fine delay of sidepanel signal in LLD clock cycles: (0, 1, 2 and 3)
	2	display_mode	display mode (display mode = 0: 9-bit for the nominal output signal, black level 288 and white level 767; display mode = 1: 10-bit for the nominal output signal, black level 64 and white level 1023)
	3	uv_inv	inverts UV input signals: 0 = no inversion, 1 = inversion
	4 to 6	ydelay_out	variable Y-delay in LLD clock cycles: -7, -6, -5, -4, -3, -2, -1 and 0
	7	en_hdsp_rst	enable hdsp reset: 0 = disable and 1 = enable

Note

1. Detailed information about the software dependent I²C-bus registers can be found in Application Note "I²C-bus register specification of the SAA4974H" (AN97042).

Basic without ADC

SAA4974H

8 LIMITING VALUES

In accordance with the Absolute Maximum Rating System (IEC 134).

SYMBOL	PARAMETER	MIN.	MAX.	UNIT
$V_{DDA(1,2)}$	analog supply voltage	-0.5	+3.45	V
$V_{DDD(1,2,3)}$	digital supply voltage	-0.5	+3.6	V
$V_{DDIO(1,2,3)}$	digital I/O supply voltage	-0.5	+5.5	V
V_i	input voltage for all I/O pins	-0.5	+5.5	V
T_{stg}	storage temperature	-20	+150	°C
T_{amb}	operating ambient temperature	-20	+70	°C

9 THERMAL CHARACTERISTICS

SYMBOL	PARAMETER	CONDITIONS	VALUE	UNIT
$R_{th(j-a)}$	thermal resistance from junction to ambient	in free air	53	K/W

Basic without ADC

SAA4974H

10 CHARACTERISTICS

$V_{DD} = 3.0$ to 3.6 V; $V_{DDA} = 3.15$ to 3.45 V; $T_{amb} = 0$ to 70 °C; unless otherwise specified.

SYMBOL	PARAMETER	CONDITIONS	MIN.	TYP.	MAX.	UNIT
Supply						
$V_{DDA(1,2)}$	analog supply voltage		3.15	3.3	3.45	V
$V_{DDD(1,2,3)}$	digital supply voltage		3.0	3.3	3.6	V
$V_{DDIO(1,2,3)}$	I/O supply voltage		4.5	5.0	5.5	V
$I_{DDA(1,2)}$	analog supply current		–	25	40	mA
$I_{DDD(1,2,3)}$	digital supply current		–	50	70	mA
$I_{DDIO(1,2,3)}$	I/O supply current		–	10	20	mA
Dissipation						
P_{tot}	total power dissipation		–	–	0.5	W
Luminance output signal (display_mode = 0: Y black level digital 288, white level digital 767; display_mode = 1: Y black level digital 64, white level digital 1023); see Fig.12						
$V_{o(p-p)}$	Y output level (peak-to-peak value)	$Z_L = 2$ k Ω	1.28	1.34	1.40	V
R_o	output resistance		–	50	100	Ω
R_L	resistive load		1	2	–	k Ω
C_L	capacitive load		–	–	25	pF
SVR	supply voltage rejection	note 1	34	–	–	dB
α_{ct}	crosstalk attenuation between outputs	0 to 10 MHz	40	–	–	dB
S/N	signal-to-noise ratio	nominal amplitude; 0 to 10 MHz	46	–	–	dB
Colour difference output signals (U and V digital range 0 to 1023)						
$V_{o(p-p)}$	U output level (peak-to-peak value)	$Z_L = 2$ k Ω	1.28	1.34	1.40	V
	V output level (peak-to-peak value)	$Z_L = 2$ k Ω	1.28	1.34	1.40	V
$G_{m(U-V)}$	gain matching U to V		–	1	3	%
R_o	output resistance		–	50	100	Ω
R_L	resistive load		1	2	–	k Ω
C_L	capacitive load		–	–	25	pF
SVR	supply voltage rejection	note 1	34	–	–	dB
α_{ct}	crosstalk attenuation between outputs	0 to 10 MHz	40	–	–	dB
S/N	signal-to-noise ratio	nominal amplitude; 0 to 10 MHz	46	–	–	dB
Output transfer function (sample rate 32 MHz/10 bits)						
INL	integral non linearity		–2	–	+2	LSB
DNL	differential non linearity		–1	–	+1	LSB

Besic without ADC

SAA4974H

SYMBOL	PARAMETER	CONDITIONS	MIN.	TYP.	MAX.	UNIT
Digital output signals: WE and RSTW ($C_L = 15$ pF); timing referred to SWC clock						
V_{OH}	HIGH-level output voltage	$I_{OH} = -2.0$ mA	2.4	–	–	V
V_{OL}	LOW-level output voltage	$I_{OL} = 1.6$ mA	–	–	0.4	V
$t_{d(o)}$	output delay time	see Fig.11	–	–	20	ns
$t_{h(o)}$	output hold time	see Fig.11	4	–	–	ns
Digital output signal: SWC ($C_L = 15$ pF); timing referred to LLA clock						
V_{OH}	HIGH-level output voltage	$I_{OH} = -2.0$ mA	2.4	–	–	V
V_{OL}	LOW-level output voltage	$I_{OL} = 1.6$ mA	–	–	0.4	V
$t_{d(o)}$	output delay time	see Fig.11	3	–	12	ns
Digital output signals: IE2, BLND, RE, HDFL and VDFL ($C_L = 15$ pF); timing referred to LLD clock						
V_{OH}	HIGH-level output voltage	$I_{OH} = -2.0$ mA	2.4	–	–	V
V_{OL}	LOW-level output voltage	$I_{OL} = 1.6$ mA	–	–	0.4	V
$t_{d(o)}$	output delay time	see Fig.11	–	–	20	ns
$t_{h(o)}$	output hold time	see Fig.11	4	–	–	ns
Digital output signal: HRD						
V_{OH}	HIGH-level output voltage	$I_{OH} = -2.0$ mA	2.4	–	–	V
V_{OL}	LOW-level output voltage	$I_{OL} = 1.6$ mA	–	–	0.4	V
Digital input/output signals: P1.1 to P1.5 and SNRST						
V_{OH}	HIGH-level output voltage	$I_{OH} = -0.06$ mA	2.4	–	–	V
V_{OL}	LOW-level output voltage	$I_{OL} = 1.6$ mA	0	–	0.45	V
V_{IH}	HIGH-level input voltage		2.0	–	5.5	V
V_{IL}	LOW-level input voltage		0	–	0.8	V
Digital input signals: YI and UVI; timing referred to LLD clock						
V_{IH}	HIGH-level input voltage		2.0	–	5.5	V
V_{IL}	LOW-level input voltage		–	–	0.8	V
$t_{su(i)}$	input set-up time	see Fig.11	4	–	–	ns
$t_{h(i)}$	input hold time	see Fig.11	3	–	–	ns
Digital input signal: HA; timing referred to LLA clock						
V_{IH}	HIGH-level input voltage		2.0	–	5.5	V
V_{IL}	LOW-level input voltage		–	–	0.8	V
$t_{su(i)}$	input set-up time	see Fig.11	7	–	–	ns
$t_{h(i)}$	input hold time	see Fig.11	4	–	–	ns

Besic without ADC

SAA4974H

SYMBOL	PARAMETER	CONDITIONS	MIN.	TYP.	MAX.	UNIT
Digital input signals: $\overline{\text{TRST}}$, TMS, RST and VA						
V_{IH}	HIGH-level input voltage		2.0	–	5.5	V
V_{IL}	LOW-level input voltage		–	–	0.8	V
Digital input clock signal: LLA						
f_{LLA}	sample clock frequency		14	16	34	MHz
δ_{clk}	clock duty factor		40	50	60	%
V_{IH}	HIGH-level input voltage		2.4	–	–	V
V_{IL}	LOW-level input voltage		–	–	0.6	V
t_r	clock rise time	see Fig.11	–	–	5	ns
t_f	clock fall time	see Fig.11	–	–	5	ns
Digital input clock signal: LLD						
f_{LLD}	sample clock frequency		30	32	34	MHz
δ_{clk}	clock duty factor		40	50	60	%
V_{IH}	HIGH-level input voltage		2.4	–	–	V
V_{IL}	LOW-level input voltage		–	–	0.6	V
t_r	clock rise time	see Fig.11	–	–	5	ns
t_f	clock fall time	see Fig.11	–	–	5	ns
I²C-bus signal: SDA and SCL; note 2						
V_{IH}	HIGH-level input voltage		$0.7V_{DDIO}$	–	–	V
V_{IL}	LOW-level input voltage		–	–	$0.3V_{DDIO}$	V
V_{OL}	LOW-level output voltage	3 mA sink current	–	–	0.4	V
f_{SCL}	SCL clock frequency		–	–	400	kHz
$t_{HD;STA}$	hold time START condition		0.6	–	–	μs
t_{LOW}	SCL LOW time		1.3	–	–	μs
t_{HIGH}	SCL HIGH time		0.6	–	–	μs
$t_{SU;DAT}$	data set-up time		100	–	–	ns
$t_{SU;DAT1}$	data set-up time (before repeated START condition)		0.6	–	–	μs
$t_{SU;DAT2}$	data set-up time (before STOP condition)		0.6	–	–	μs
$t_{SU;STA}$	set-up time repeated START		0.6	–	–	μs
$t_{SU;STO}$	set-up time STOP condition		0.6	–	–	μs

Basic without ADC

SAA4974H

SYMBOL	PARAMETER	CONDITIONS	MIN.	TYP.	MAX.	UNIT
SNERT-bus: SNDA and SNCL; note 3						
V _{OH}	HIGH-level output voltage	I _{OH} = -2.0 mA	2.4	-	-	V
V _{OL}	LOW-level output voltage	I _{OL} = 1.6 mA	-	-	0.4	V
V _{IH}	HIGH-level input voltage		2.0	-	5.5	V
V _{IL}	LOW-level input voltage		-	-	0.8	V
t _{su(i)}	input set-up time		700	-	-	ns
t _{h(i)}	input hold time		0	-	-	ns
t _{cycle}	SNCL cycle time		-	1	-	μs
t _{h(o)}	output hold time		50	-	-	ns

Notes

- Supply voltage ripple rejection, measured over a frequency range from 20 Hz to 50 kHz. This includes 1/2f_V, f_V, 2f_V, f_H and 2f_H which are major load frequencies: SVR is relative variation of the full scale analog input for a supply variation of 0.25 V.
- The AC characteristics are in accordance with the I²C-bus specification for fast mode (clock frequency maximum 400 kHz). Information about the I²C-bus can be found in brochure "I²C-bus and how to use it" (order number 9398 393 40011).
- More information about the SNERT-bus protocol can be found in Application Note "The SNERT-bus specification" (AN95127).

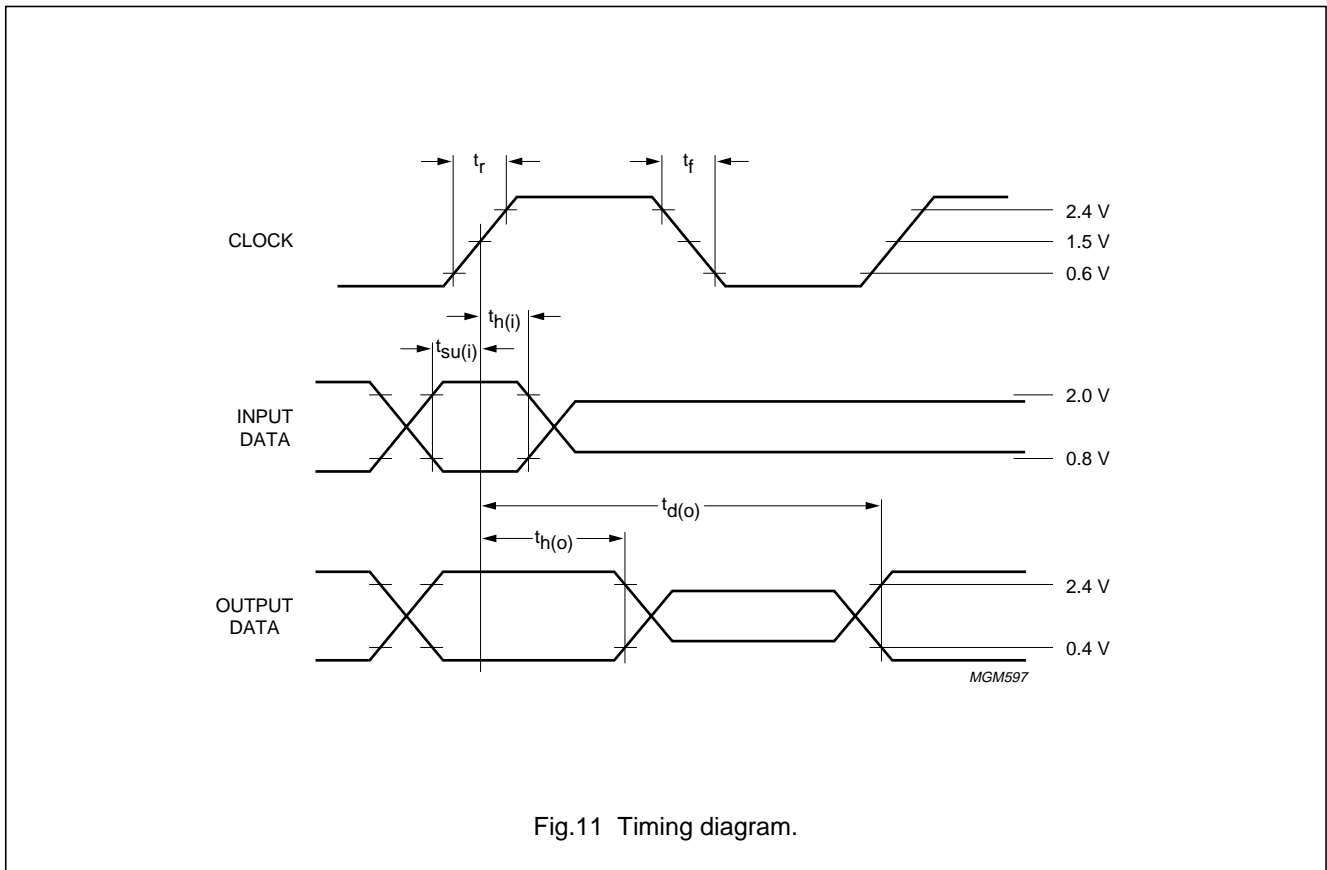

Fig.11 Timing diagram.

Basic without ADC

SAA4974H

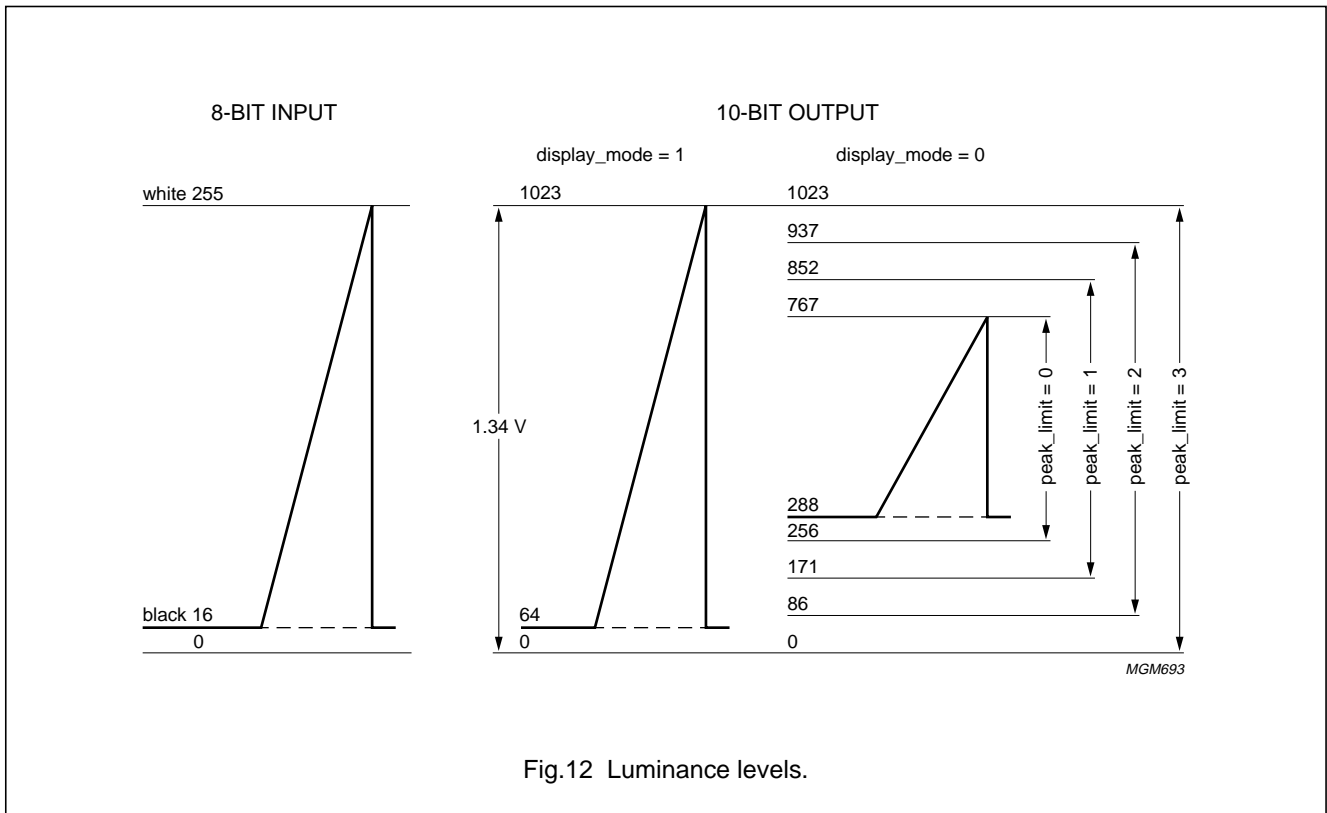

Fig.12 Luminance levels.

11 APPLICATION

The SAA4974H supports two different up-converter concepts. The simple one is shown in Fig.13. In this application only one field memory SAA4955TJ is needed for a 100 Hz conversion based on a field repetition algorithm (AABB mode). The concept can be upgraded by a noise reduction based on a motion adaptive field recursive filter if the SAA4956TJ is used instead of the SAA4955TJ.

The SAA4974H supports a dual-clock system. The acquisition clock is taken from the digital front-end. The display control is based on a clock generated by an external H-PLL. By this structure the stability of the display is enhanced compared to a one-clock system if an unstable source like a VCR is used as an input. For low-cost applications it is possible to run the IC as a one-clock system.

The second system supported by the SAA4974H is shown in Fig.14. This concept needs two field memories (SAA4955TJ) and the signal processing IC MELZONIC (SAA4991WP). The SAA4991WP allows a vector based motion estimation and compensation for a display of 100 Hz pictures in high-end TV sets which is free of motion artefacts. It additionally provides a variable vertical zoom function, noise and cross colour reduction. Furthermore a multi-PIP feature is supported making use of the field memories.

Basic without ADC

SAA4974H

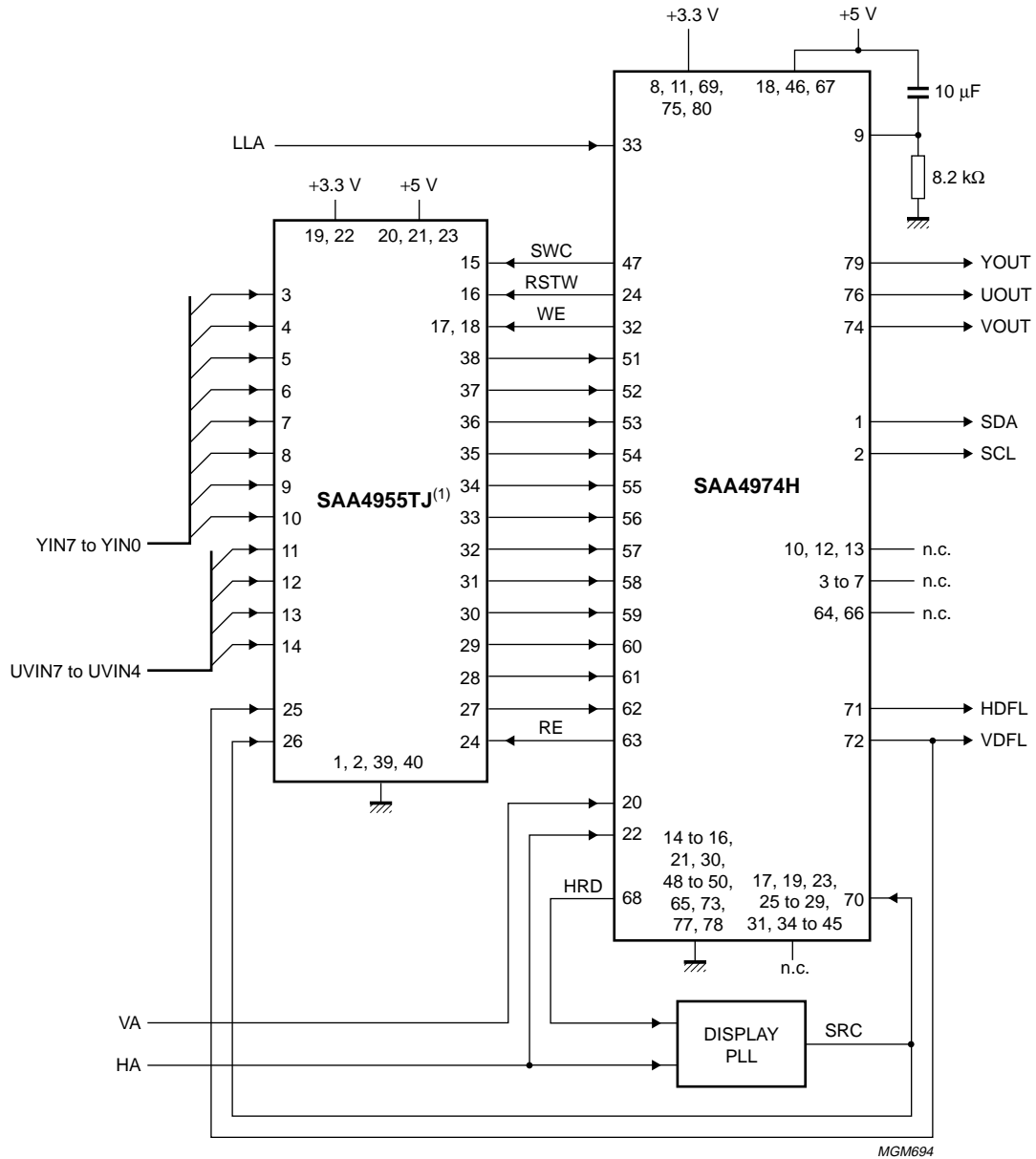

(1) Alternatively SAA4956TJ.

Fig.13 Application diagram 1.

Basic without ADC

SAA4974H

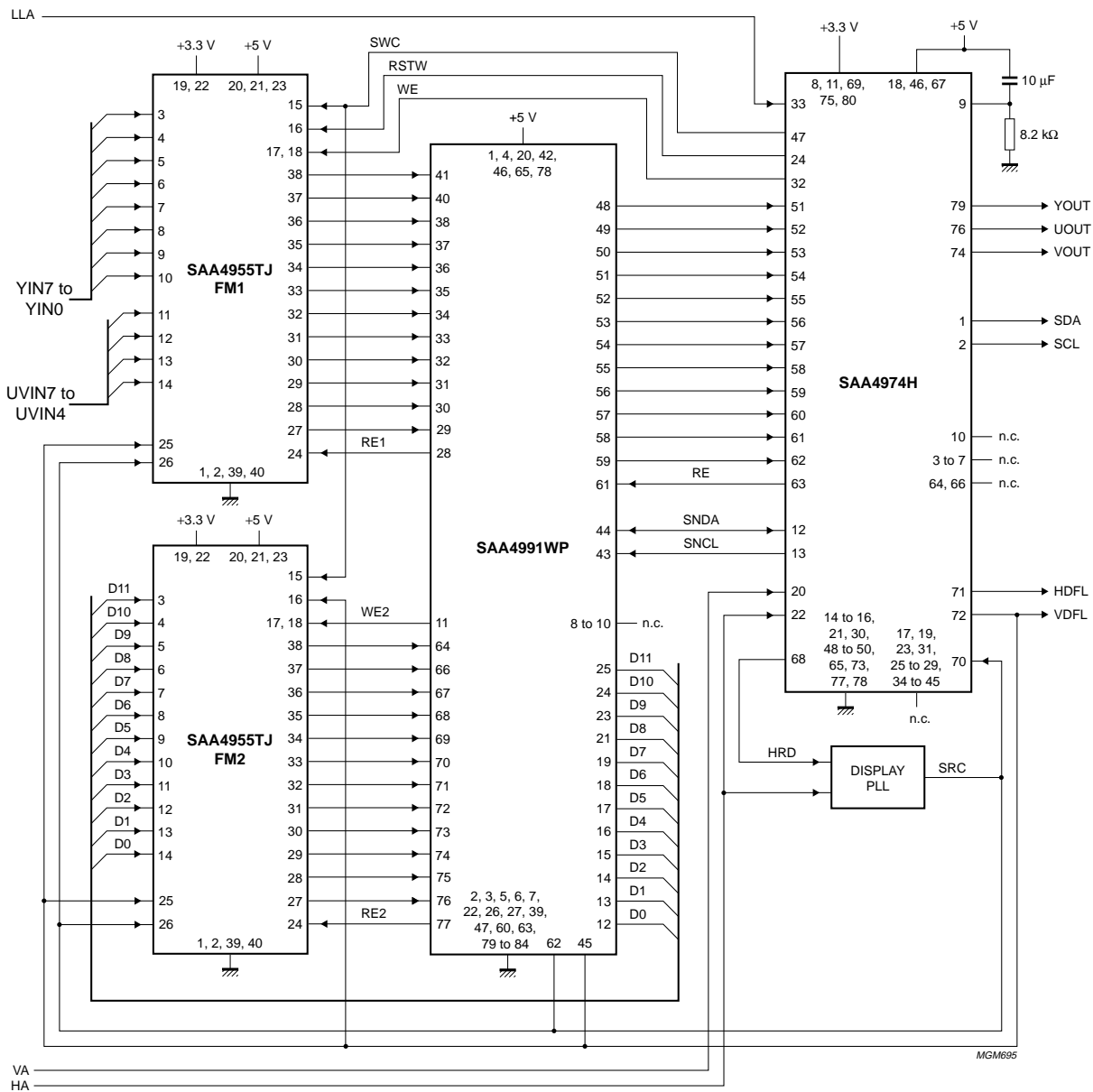

Fig.14 Application diagram 2.

MGM695

Basic without ADC

SAA4974H

12 PACKAGE OUTLINE

QFP80: plastic quad flat package; 80 leads (lead length 1.95 mm); body 14 x 20 x 2.8 mm

SOT318-2

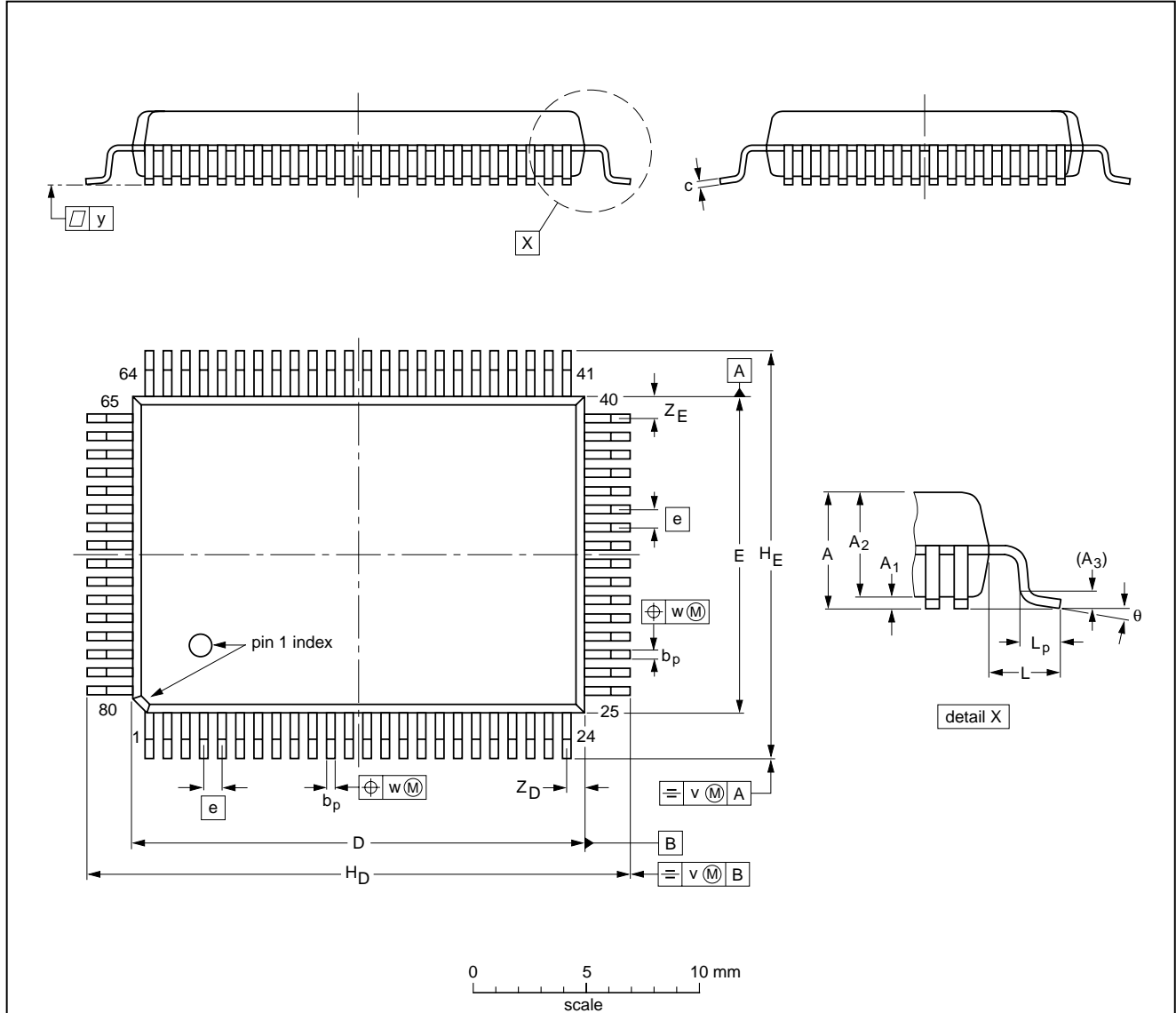

DIMENSIONS (mm are the original dimensions)

UNIT	A max.	A ₁	A ₂	A ₃	b _p	c	D ⁽¹⁾	E ⁽¹⁾	e	H _D	H _E	L	L _p	v	w	y	Z _D ⁽¹⁾	Z _E ⁽¹⁾	θ
mm	3.2	0.25 0.05	2.90 2.65	0.25	0.45 0.30	0.25 0.14	20.1 19.9	14.1 13.9	0.8	24.2 23.6	18.2 17.6	1.95	1.0 0.6	0.2	0.2	0.1	1.0 0.6	1.2 0.8	7° 0°

Note

1. Plastic or metal protrusions of 0.25 mm maximum per side are not included.

OUTLINE VERSION	REFERENCES				EUROPEAN PROJECTION	ISSUE DATE
	IEC	JEDEC	EIAJ			
SOT318-2						95-02-04 97-08-01

Besic without ADC

SAA4974H

13 SOLDERING

13.1 Introduction

There is no soldering method that is ideal for all IC packages. Wave soldering is often preferred when through-hole and surface mounted components are mixed on one printed-circuit board. However, wave soldering is not always suitable for surface mounted ICs, or for printed-circuits with high population densities. In these situations reflow soldering is often used.

This text gives a very brief insight to a complex technology. A more in-depth account of soldering ICs can be found in our *"Data Handbook IC26; Integrated Circuit Packages"* (order code 9398 652 90011).

13.2 Reflow soldering

Reflow soldering techniques are suitable for all QFP packages.

The choice of heating method may be influenced by larger plastic QFP packages (44 leads, or more). If infrared or vapour phase heating is used and the large packages are not absolutely dry (less than 0.1% moisture content by weight), vaporization of the small amount of moisture in them can cause cracking of the plastic body. For details, refer to the Drypack information in the *"Data Handbook IC26; Integrated Circuit Packages; Section: Packing Methods"*.

Reflow soldering requires solder paste (a suspension of fine solder particles, flux and binding agent) to be applied to the printed-circuit board by screen printing, stencilling or pressure-syringe dispensing before package placement.

Several methods exist for reflowing; for example, infrared/convection heating in a conveyor type oven. Throughput times (preheating, soldering and cooling) vary between 50 and 300 seconds depending on heating method. Typical reflow peak temperatures range from 215 to 250 °C.

13.3 Wave soldering

Wave soldering is **not** recommended for QFP packages. This is because of the likelihood of solder bridging due to closely-spaced leads and the possibility of incomplete solder penetration in multi-lead devices.

If wave soldering cannot be avoided, for QFP packages with a pitch (e) larger than 0.5 mm, the following conditions must be observed:

- **A double-wave (a turbulent wave with high upward pressure followed by a smooth laminar wave) soldering technique should be used.**
- **The footprint must be at an angle of 45° to the board direction and must incorporate solder thieves downstream and at the side corners.**

During placement and before soldering, the package must be fixed with a droplet of adhesive. The adhesive can be applied by screen printing, pin transfer or syringe dispensing. The package can be soldered after the adhesive is cured.

Maximum permissible solder temperature is 260 °C, and maximum duration of package immersion in solder is 10 seconds, if cooled to less than 150 °C within 6 seconds. Typical dwell time is 4 seconds at 250 °C.

A mildly-activated flux will eliminate the need for removal of corrosive residues in most applications.

13.4 Repairing soldered joints

Fix the component by first soldering two diagonally-opposite end leads. Use only a low voltage soldering iron (less than 24 V) applied to the flat part of the lead. Contact time must be limited to 10 seconds at up to 300 °C. When using a dedicated tool, all other leads can be soldered in one operation within 2 to 5 seconds between 270 and 320 °C.

CAUTION
Wave soldering is NOT applicable for all QFP packages with a pitch (e) equal or less than 0.5 mm.

Basic without ADC

SAA4974H

14 DEFINITIONS

Data sheet status	
Objective specification	This data sheet contains target or goal specifications for product development.
Preliminary specification	This data sheet contains preliminary data; supplementary data may be published later.
Product specification	This data sheet contains final product specifications.
Limiting values	
Limiting values given are in accordance with the Absolute Maximum Rating System (IEC 134). Stress above one or more of the limiting values may cause permanent damage to the device. These are stress ratings only and operation of the device at these or at any other conditions above those given in the Characteristics sections of the specification is not implied. Exposure to limiting values for extended periods may affect device reliability.	
Application information	
Where application information is given, it is advisory and does not form part of the specification.	

15 LIFE SUPPORT APPLICATIONS

These products are not designed for use in life support appliances, devices, or systems where malfunction of these products can reasonably be expected to result in personal injury. Philips customers using or selling these products for use in such applications do so at their own risk and agree to fully indemnify Philips for any damages resulting from such improper use or sale.

16 PURCHASE OF PHILIPS I²C COMPONENTS



Purchase of Philips I²C components conveys a license under the Philips' I²C patent to use the components in the I²C system provided the system conforms to the I²C specification defined by Philips. This specification can be ordered using the code 9398 393 40011.

Basic without ADC

SAA4974H

NOTES

Philips Semiconductors – a worldwide company

Argentina: see South America

Australia: 34 Waterloo Road, NORTH RYDE, NSW 2113, Tel. +61 2 9805 4455, Fax. +61 2 9805 4466

Austria: Computerstr. 6, A-1101 WIEN, P.O. Box 213, Tel. +43 160 1010, Fax. +43 160 101 1210

Belarus: Hotel Minsk Business Center, Bld. 3, r. 1211, Volodarski Str. 6, 220050 MINSK, Tel. +375 172 200 733, Fax. +375 172 200 773

Belgium: see The Netherlands

Brazil: see South America

Bulgaria: Philips Bulgaria Ltd., Energoproject, 15th floor, 51 James Bourchier Blvd., 1407 SOFIA, Tel. +359 2 689 211, Fax. +359 2 689 102

Canada: PHILIPS SEMICONDUCTORS/COMPONENTS, Tel. +1 800 234 7381

China/Hong Kong: 501 Hong Kong Industrial Technology Centre, 72 Tat Chee Avenue, Kowloon Tong, HONG KONG, Tel. +852 2319 7888, Fax. +852 2319 7700

Colombia: see South America

Czech Republic: see Austria

Denmark: Prags Boulevard 80, PB 1919, DK-2300 COPENHAGEN S, Tel. +45 32 88 2636, Fax. +45 31 57 0044

Finland: Sinikalliontie 3, FIN-02630 ESPOO, Tel. +358 9 615800, Fax. +358 9 61580920

France: 51 Rue Carnot, BP317, 92156 SURESNES Cedex, Tel. +33 1 40 99 6161, Fax. +33 1 40 99 6427

Germany: Hammerbrookstraße 69, D-20097 HAMBURG, Tel. +49 40 23 53 60, Fax. +49 40 23 536 300

Greece: No. 15, 25th March Street, GR 17778 TAVROS/ATHENS, Tel. +30 1 4894 339/239, Fax. +30 1 4814 240

Hungary: see Austria

India: Philips INDIA Ltd, Band Box Building, 2nd floor, 254-D, Dr. Annie Besant Road, Worli, MUMBAI 400 025, Tel. +91 22 493 8541, Fax. +91 22 493 0966

Indonesia: PT Philips Development Corporation, Semiconductors Division, Gedung Philips, Jl. Buncit Raya Kav.99-100, JAKARTA 12510, Tel. +62 21 794 0040 ext. 2501, Fax. +62 21 794 0080

Ireland: Newstead, Clonskeagh, DUBLIN 14, Tel. +353 1 7640 000, Fax. +353 1 7640 200

Israel: RAPAC Electronics, 7 Kehilat Saloniki St, PO Box 18053, TEL AVIV 61180, Tel. +972 3 645 0444, Fax. +972 3 649 1007

Italy: PHILIPS SEMICONDUCTORS, Piazza IV Novembre 3, 20124 MILANO, Tel. +39 2 6752 2531, Fax. +39 2 6752 2557

Japan: Philips Bldg 13-37, Kohnan 2-chome, Minato-ku, TOKYO 108, Tel. +81 3 3740 5130, Fax. +81 3 3740 5077

Korea: Philips House, 260-199 Itaewon-dong, Yongsan-ku, SEOUL, Tel. +82 2 709 1412, Fax. +82 2 709 1415

Malaysia: No. 76 Jalan Universiti, 46200 PETALING JAYA, SELANGOR, Tel. +60 3 750 5214, Fax. +60 3 757 4880

Mexico: 5900 Gateway East, Suite 200, EL PASO, TEXAS 79905, Tel. +9-5 800 234 7381

Middle East: see Italy

Netherlands: Postbus 90050, 5600 PB EINDHOVEN, Bldg. VB, Tel. +31 40 27 82785, Fax. +31 40 27 88399

New Zealand: 2 Wagener Place, C.P.O. Box 1041, AUCKLAND, Tel. +64 9 849 4160, Fax. +64 9 849 7811

Norway: Box 1, Manglerud 0612, OSLO, Tel. +47 22 74 8000, Fax. +47 22 74 8341

Pakistan: see Singapore

Philippines: Philips Semiconductors Philippines Inc., 106 Valero St. Salcedo Village, P.O. Box 2108 MCC, MAKATI, Metro MANILA, Tel. +63 2 816 6380, Fax. +63 2 817 3474

Poland: Ul. Lukiska 10, PL 04-123 WARSZAWA, Tel. +48 22 612 2831, Fax. +48 22 612 2327

Portugal: see Spain

Romania: see Italy

Russia: Philips Russia, Ul. Usatcheva 35A, 119048 MOSCOW, Tel. +7 095 755 6918, Fax. +7 095 755 6919

Singapore: Lorong 1, Toa Payoh, SINGAPORE 319762, Tel. +65 350 2538, Fax. +65 251 6500

Slovakia: see Austria

Slovenia: see Italy

South Africa: S.A. PHILIPS Pty Ltd., 195-215 Main Road Martindale, 2092 JOHANNESBURG, P.O. Box 7430 Johannesburg 2000, Tel. +27 11 470 5911, Fax. +27 11 470 5494

South America: Al. Vicente Pinzon, 173, 6th floor, 04547-130 SÃO PAULO, SP, Brazil, Tel. +55 11 821 2333, Fax. +55 11 821 2382

Spain: Balmes 22, 08007 BARCELONA, Tel. +34 3 301 6312, Fax. +34 3 301 4107

Sweden: Kottbygatan 7, Akalla, S-16485 STOCKHOLM, Tel. +46 8 5985 2000, Fax. +46 8 5985 2745

Switzerland: Allmendstrasse 140, CH-8027 ZÜRICH, Tel. +41 1 488 2741 Fax. +41 1 488 3263

Taiwan: Philips Semiconductors, 6F, No. 96, Chien Kuo N. Rd., Sec. 1, TAIPEI, Taiwan Tel. +886 2 2134 2865, Fax. +886 2 2134 2874

Thailand: PHILIPS ELECTRONICS (THAILAND) Ltd., 209/2 Sanpavuth-Bangna Road Prakanong, BANGKOK 10260, Tel. +66 2 745 4090, Fax. +66 2 398 0793

Turkey: Talatpasa Cad. No. 5, 80640 GÜLTEPE/ISTANBUL, Tel. +90 212 279 2770, Fax. +90 212 282 6707

Ukraine: PHILIPS UKRAINE, 4 Patrice Lumumba str., Building B, Floor 7, 252042 KIEV, Tel. +380 44 264 2776, Fax. +380 44 268 0461

United Kingdom: Philips Semiconductors Ltd., 276 Bath Road, Hayes, MIDDLESEX UB3 5BX, Tel. +44 181 730 5000, Fax. +44 181 754 8421

United States: 811 East Arques Avenue, SUNNYVALE, CA 94088-3409, Tel. +1 800 234 7381

Uruguay: see South America

Vietnam: see Singapore

Yugoslavia: PHILIPS, Trg N. Pasica 5/v, 11000 BEOGRAD, Tel. +381 11 625 344, Fax. +381 11 635 777

For all other countries apply to: Philips Semiconductors, International Marketing & Sales Communications, Building BE-p, P.O. Box 218, 5600 MD EINDHOVEN, The Netherlands, Fax. +31 40 27 24825

Internet: <http://www.semiconductors.philips.com>

© Philips Electronics N.V. 1998

SCA59

All rights are reserved. Reproduction in whole or in part is prohibited without the prior written consent of the copyright owner.

The information presented in this document does not form part of any quotation or contract, is believed to be accurate and reliable and may be changed without notice. No liability will be accepted by the publisher for any consequence of its use. Publication thereof does not convey nor imply any license under patent- or other industrial or intellectual property rights.

Printed in The Netherlands

545104/00/01/pp28

Date of release: 1998 Apr 21

Document order number: 9397 750 03018

Let's make things better.

**Philips
Semiconductors**



PHILIPS