

FEATURES

- 50 - 1300 MHz
- 40 dB Range
- 1.3 dB Insertion Loss
- ± 2 dB Linearity
- See 100C1521 For Connectorized Version



MODEL NO.
DA0243

PIN Diode Linear VCA

VCA

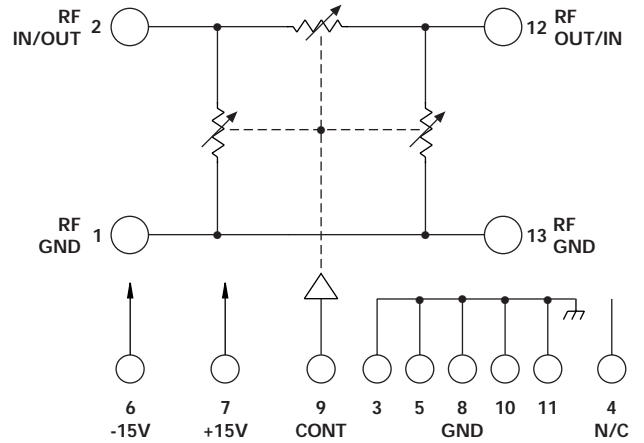
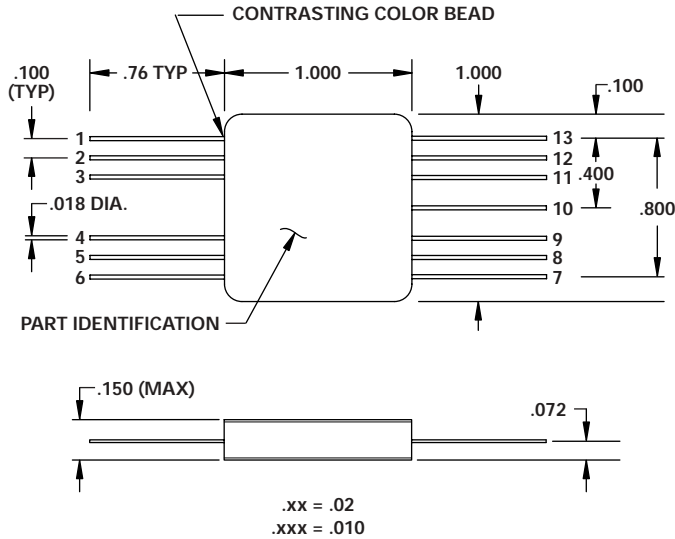

N/C = NO INTERNAL CORRECTION

TYPICAL PERFORMANCE

Attenuation vs Control Voltage
at 500 MHz

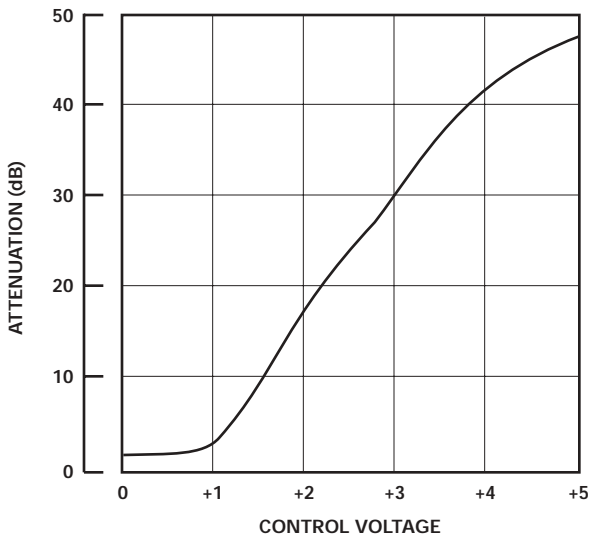

GUARANTEED PERFORMANCE

Parameter	Min	Typ	Max	Units	Conditions
Operating Frequency	50		1300	MHz	
DC Current		60 80	65 110	mA	At +15 VDC Supply At -15 VDC Supply
Control Current			1	mA	0 V = I.L. +5 V = Max. Atten.
Insertion Loss			2.0 3.0 3.5	dB	50 - 500 MHz 500 - 1100 MHz 1100 - 1300 MHz
Attenuation	Range	40 30 25		dB	50 - 500 MHz 500 - 1100 MHz 1100 - 1300 MHz
	Slope	13 \pm 3		dB/V	
	Linearity	± 2		dB	Best Straight Line Fit From: IL +2 dB to 35 dB at 50 - 500 MHz IL +2 dB to 25 dB at 500 - 1100 MHz IL +2 dB to 20 dB at 1100 - 1300 MHz
VSWR			1.25/1 1.50/1		50 - 500 MHz 500 - 1300 MHz
Impedance		50		OHMS	
Slew Rate		3		dB/ μ s	
Intercept Points	2nd 3rd	+80 +35		dBm	
RF Power	Operate		+10	dBm	
Operating Temperature	-55	+25	+85	$^{\circ}$ C	TA