



DC COMPONENTS CO., LTD.

DISCRETE SEMICONDUCTORS

DC9015

TECHNICAL SPECIFICATIONS OF PNP EPITAXIAL PLANAR TRANSISTOR

Description

Designed for use in pre-amplifier of low level and low noise.

Pinning

- 1 = Emitter
- 2 = Base
- 3 = Collector

Absolute Maximum Ratings (T_A=25°C)

Characteristic	Symbol	Rating	Unit
Collector-Base Voltage	V _{CB0}	-50	V
Collector-Emitter Voltage	V _{CE0}	-45	V
Emitter-Base Voltage	V _{EB0}	-5	V
Collector Current	I _C	-100	mA
Total Power Dissipation	P _D	450	mW
Junction Temperature	T _J	+150	°C
Storage Temperature	T _{STG}	-55 to +150	°C

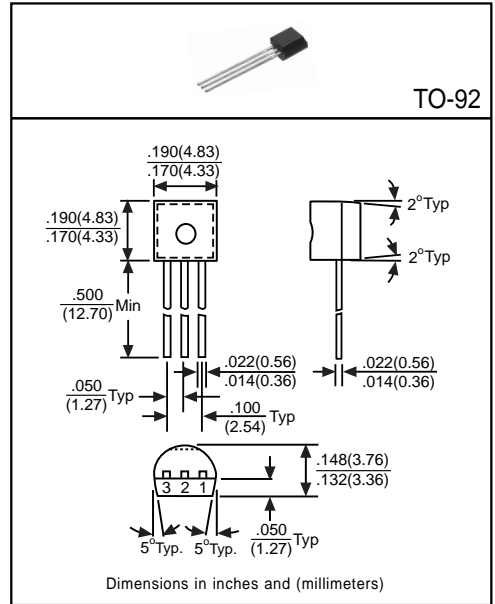

Electrical Characteristics

(Ratings at 25°C ambient temperature unless otherwise specified)

Characteristic	Symbol	Min	Typ	Max	Unit	Test Conditions
Collector-Base Breakdown Voltage	BV _{CB0}	-50	-	-	V	I _C =-100μA, I _E =0
Collector-Emitter Breakdown Voltage	BV _{CE0}	-45	-	-	V	I _C =-1mA, I _B =0
Emitter-Base Breakdown Voltage	BV _{EB0}	-5	-	-	V	I _E =-100μA, I _C =0
Collector Cutoff Current	I _{CBO}	-	-	-50	nA	V _{CB} =-50V, I _E =0
Emitter Cutoff Current	I _{EBO}	-	-	-50	nA	V _{EB} =-5V, I _C =0
Collector-Emitter Saturation Voltage ⁽¹⁾	V _{CE(sat)}	-	-0.2	-0.7	V	I _C =-100mA, I _B =-5mA
Base-Emitter Saturation Voltage ⁽¹⁾	V _{BE(sat)}	-	-0.82	-1	V	I _C =-100mA, I _B =-5mA
Base-Emitter On Voltage	V _{BE(on)}	-0.6	-0.65	-0.75	V	I _C =-2mA, V _{CE} =-5V
DC Current Gain ⁽¹⁾	h _{FE}	60	-	1000	-	I _C =-1mA, V _{CE} =-5V
Transition Frequency	f _T	100	190	-	MHz	I _C =-10mA, V _{CE} =-5V
Output Capacitance	C _{ob}	-	4.5	7	pF	V _{CB} =-10V, f=1MHz, I _E =0

(1) Pulse Test: Pulse Width ≤ 380μs, Duty Cycle ≤ 2%

Classification of h_{FE}

Rank	A	B	C	D
Range	60~150	100~300	200~600	400~1000