

## **Scope**

In some LED lighting applications, precise light intensity control is a must. For instance in shops where multiple LED lighted panels are installed one next to the other, the light intensity and light color of the individual panels needs to be exactly the same.

Also in automotive applications, like LED headlamps, it is important that LED light levels comply with specifications over time and over temperature.

This document describes 2 schematics for LED light closed loop control:

- Schematic 1: MLX75305 Light-to-Voltage Converter only
- Schematic 2: MLX10803 LED Driver with MLX75305

Which circuit is suited for your application depends on:

- Low current LED drive versus high current LED drive (LED Driver MLX10803 recommended)
- Microprocessor/microcontroller available or not

The aim of this application note is to make a closed light regulation loop with a LED and a MLX75305 featuring a minimal number of components. Note: this paper does not show an automotive reference design. Its sole purpose is to provide a design example for fast prototyping and evaluation.

## **Applications**

### **General**

- LED Lighting for shops
- Other LED Lighting applications where precise light intensity control is required

### **Automotive**

- LED Headlamps

## **Related Melexis Products**

- MLX75303 Automotive Optical Switch
- MLX75304 Light-to-Frequency Converter
- MLX75305 Light-to-Voltage Converter

## **Contents**

- LED Light Closed Control Loop with Light Sensor only
- LED Light Closed Control Loop with Light Sensor and Microprocessor
- LED Light Closed Control Loop with Light Sensor and LED Driver

### LED Light Closed Control Loop with Light Sensor only

The output voltage of the MLX75305 varies linearly with incident light intensity. So, when incident light intensity on the MLX75305 doubles, then the output voltage of the MLX75305 doubles as well.

As the output of the MLX75305 increases with light, we need to do a sign inversion of its output voltage to make a negative feedback loop. Without sign inversion a positive feedback is created leading to an unstable system.

#### Schematic 1

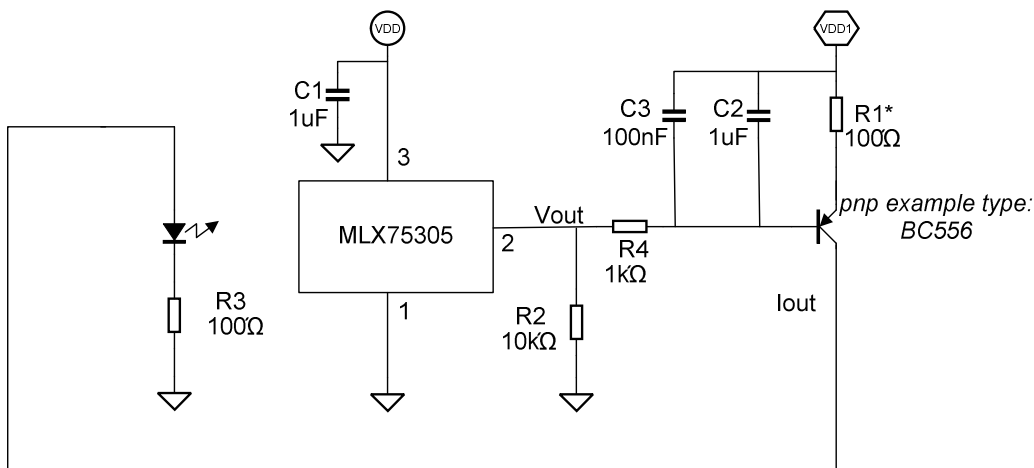

This circuit will regulate the LED current to a stable value.

When LED light on the MLX75305 increases, output voltage of the MLX75305 ( $V_{out}$ ) increases as well. This diminishes pMOS LED current ( $I_{out}$ ). A stable state will occur on the crossing of  $V_{out}$  and  $I_{out}$ .

$$V_{out} \approx VDD - I_{out} \times R1 - \text{threshold voltage of pMOS}$$

Case1: When there is no light,  $V_{out}$  will be 0. This switches the PMOS completely "ON" and thus increases the LED current  $I_{out}$  and generates more light. As a consequence, the  $V_{out}$  will start to rise.

Case2: If the LED is completely "ON",  $V_{out}$  will be at full scale which turns the PMOS "OFF" and so, blocking the LED current  $I_{out}$ .

In steady-state, the system will regulate the LED current to a stable position, depending on the values of the passive components.

#### Component Description

- C1 is decoupling capacitor for VDD. R2 is the pull-down resistor for MLX75305.
- R1 is used to change light level regulation emitted by LED: increase R1 to have a lower light level and decrease R1 to have a higher one. When changing R1, make sure to

provide sufficient voltage head-room to allow the LED and PMOS to operate properly. R1 should be a precision resistor with low TC because it defines the light output value of the regulation system.

- R3 sets the maximum LED current for LED protection. When applying a large LED current, voltage drop over R3 will limit the max LED current. Note: because R3 is included in the closed loop, its value does NOT change the gain of the system nor the settling point of the loop.

The product  $R3*(C2+C3)$  determines the dominant system pole, so it sets the maximum operating frequency or regulation speed of the system. The C2 and C3 capacitors define system response speed and system stability. Two capacitors are used in parallel to have good response over a wider frequency range. A larger  $R3*(C2+C3)$  makes the system slower, but more stable. Depending on system specifics, appropriate values of the R and C values must be selected. These components' values can be regulated to stabilize the loop depends on different applications.

Transistor and LED can be replaced by other type depends on users application. For transistor: pMOS, power transistor and Darlington pairs are all optional. If one use other transistor or LED type, ALWAYS check the current flowing through and choose the right R3 and R1's values to make sure transistor will work properly, and regulate C2 and C3's values to make system stable.

### Integrated Light Sensor versus photoresistor

The use of an integrated light sensor features following benefits in automotive designs:

- Integrated high gain with no need for external high resistor values (good practice in automotive designs indicate low resistor values)
- High linearity
- Other benefits related to the MLX75305
  - Automotive qualification AEC-Q100, low ppm
  - Operating temperature up to 125degC
  - Solder reflow 260degC
  - Guaranteed and precise min/max specification for light responsivity
  - Low temperature dependency
  - RoHS compliant

### Connecting the MLX75305 directly to 12V or automotive battery power

The standard VDD range for the MLX75305 is 3V3 .. 5V

However, by using 2 extra external components, one could connect the MLX75305 light 2 voltage opto-sensor directly to V-battery.

### Required Components

1. R in series with Vbat
2. ZenerDiode in parallel to the MLX75305 to fix the VDD to 4.7V (eg. 1N4614)
3. Good decoupling Cap (should always be present anyhow)

### Component Dimensioning Example

1. min. V-bat = 6V (example)
2. ZenerDiode could give 4.7V to the MLX75305, so there can be worst case a V-drop over the seriesR of 1V3 (6V-4V7). With a worst case I-consumption of 3mA (MLX75305) + <1mA (Load) + <1mA (for a Zener), this gives a total worst case current budget of <5mA, leading to a max. R value of 270Ohm. (270Ohm x 5mA gives the max. allowed Vdrop of 1V3)
3. max V-bat = 18V (example)
4. The ZenerDiode can get a worst case current of 50mA (18V-4V7)/270Ohm, so it should be robust against such current levels and 250mW power dissipation.
5. The R should be able to resist 0.7W (13V \* 50mA)
6. decoupling C: with a 10uF // 100nF, we have an RC effect of 2.7ms (R\*C)

Note: with 2 external components, the MLX75305 can be connected directly to the V-battery. For robust automotive design, some guardbending on the dimensioning should be taken into account to compensate for all worst case conditions.

### Using a voltage reference in stead of a resistor reference

An opamp could be added to control the closed loop using a voltage reference in stead of a resistor value reference. This adds an additional component to the bill of material.

### ***LED Light Closed Control Loop with Light Sensor and Microprocessor***

Additionally to the MLX75305 light-to-voltage converter, the MLX75304 light-to-frequency converter may be a good alternative in case a microprocessor is available.

When using the MLX75305 light-to-voltage converter, the microprocessor reads the (positive) output voltage into its internal ADC. The micro calculates the feedback control signal in software. When using the MLX75304 light-to-frequency converter, the micro uses its digital counter input to read the signal transitions (half periods) from the light-to-frequency converter's output.

Note: less external components are needed when a microprocessor is available.

**LED Light Closed Control Loop with Light Sensor and LED Driver**

For high current LED applications, we recommend to include the MLX10803 LED Driver

**Schematic 2**

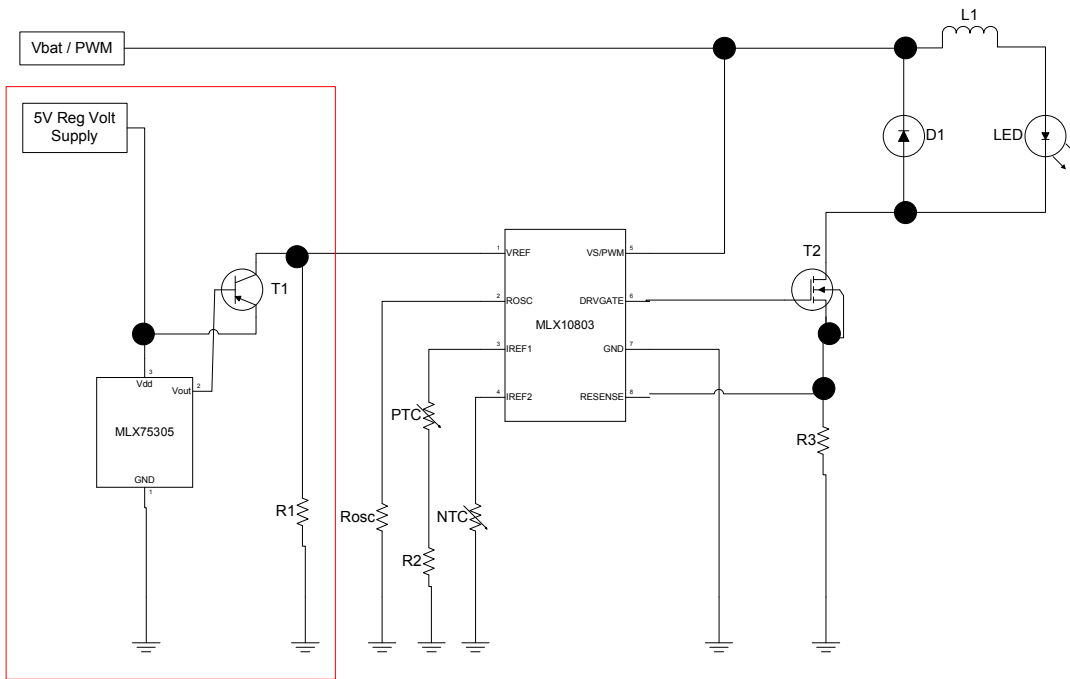

In this example, requirements of higher current LED drive are considered. The circuit outside of the red box is a standard implementation of the MLX10803 (High Power LED Driver). The basic operating principle here is that the LED is driven by a switch mode power supply using an inductor as an energy storage element. Furthermore, for applications where thermal considerations are critical, PTC and NTC resistors are connected to the REF1 and REF2, respectively, for temperature compensation of the LED output.

The voltage output of MLX75305 (Light-to-Voltage Converter), which is directly proportional to light intensity, is inverted via the PNP Bipolar Transistor (T1) into the VREF pin of the MLX10803. The VREF pin of the MLX10803 can be used to limit the peak current over R3 and determine the average current over the LEDs. In this way, the customer can decide a target value for peak LED current by the sizing of R1. The MLX75305 requires a 5 Volt supply input (see above for solutions for a 12V system).