

## EPF8183SP

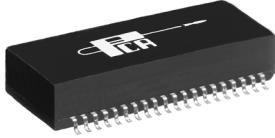

- Significantly Improved Common Mode Attenuation
- Guaranteed to operate with 8 mA DC Bias at 70°C
- Cable Side Surge, EFT and ESD Protection Included
- Complies with or exceeds IEEE 802.3, 10/100Base-TX Standards

### Electrical Parameters @ 25° C

OCL ( $\mu$ H Min.)	Insertion Loss (dB Max.)		Return Loss (dB Min.)			Common Mode Rejection (dB Min.)				Crosstalk (dB Min.)
	1-80 MHz	150 MHz	30 MHz	30-60 MHz	60-80 MHz	30 MHz	100 MHz	200 MHz	300-500 MHz	
100 KHz, 0.1 Vrms 8 mA DC Bias										
<b>Cable Side</b>	Xmit/Rcv	Xmit/Rcv	Xmit/Rcv	Xmit/Rcv	Xmit/Rcv	Xmit/Rcv	Xmit/Rcv	Xmit/Rcv	Xmit/Rcv	
350	-1/-1	-3/-3	-18/-18	18-20 lof f/30	-14/-14	-35/-35	-25/-25	-25/-25	-10/-10	-38

• Isolation : 1500 Vrms • Cable Side Impedance : 100  $\Omega$  • Common to Differential Rejection : -40 dB Min. (Xmit/Rcv) @ 1-100 MHz •

### Schematic

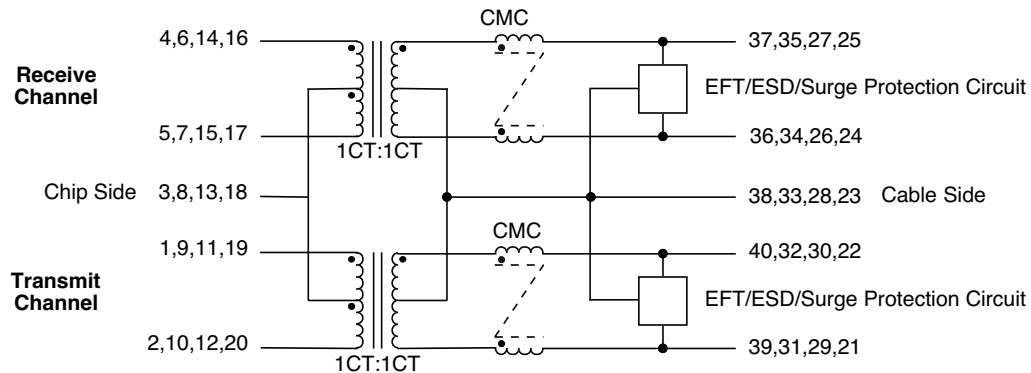

### Package

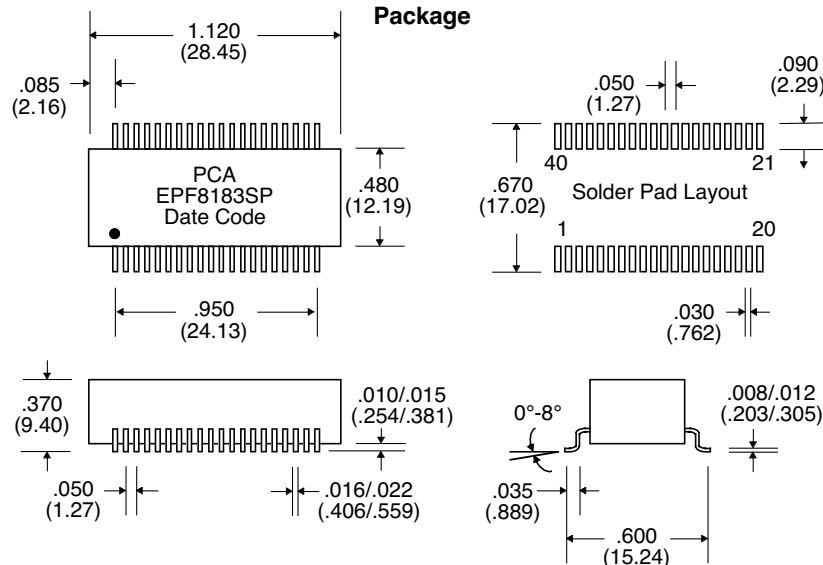

Unless Otherwise Specified Dimensions are in Inches /mm  $\pm$  .010 / .25