

MULTI-RATE OC-48/STM-16 SFP TRANSCEIVERS WITH DIGITAL DIAGNOSTICS

TRXA48M Single Mode



Product Description

The TRXA48M SFP series of multi-rate fiber optic transceivers with digital diagnostics monitoring functionality provide a quick and reliable interface for short reach (SR), intermediate reach (IR) and long reach (LR) applications. Diagnostics monitoring functionality (alarm and warning features) is integrated into the design via an I²C serial interface per the Multi-Source Agreement (MSA) SFF-8472, Rev. 9.4.

Products under this series are compatible with SONET/ SDH standards for OC-48/STM-16 (2.488Gb/s) SR-1/I-16 short reach, IR-1/S-16.1 & IR-2/S-16.2 intermediate reach and LR-1/L-16.1 & LR-2/L-16.2 long reach applications, OC-3/STM-1 (156Mb/s) and OC-12/STM-4 (622Mb/s) SR/I-1 and I-4 short reach applications; Gigabit Ethernet LX (1.25Gb/s) applications per IEEE 802.3; and Fibre Channel 200-SM-LC-L (2.125Gb/s) and 100-SM-LC-L (1.062Gb/s) applications per FC-PI standards. The transceivers support data rates ranging from 2.67Gb/s down to 125Mb/s. All modules satisfy Class I Laser Safety requirements in accordance with the U.S. FDA/CDRH and international IEC-60825 standards.

The TRXA48 multi-rate transceivers connect to standard 20-pad SFP connectors for hot plug capability. This allows the system designer to make configuration changes or maintenance by simply plugging in different types of transceivers without removing the power supply from the host system.

The transceivers have colored bail-type latches, which offer an easy and convenient way to release the modules. The latch is compliant with the SFP MSA.

The transmitter and receiver DATA interfaces are AC-coupled internally. LV-TTL Transmitter Disable control input and Loss of Signal output interfaces are also provided.

The transceivers operate from a single +3.3V power supply over an operating case temperature range of -5°C to +70°C or -40°C to +85°C. The housing is made of metal for EMI immunity.



Features

- ☑ Lead Free Design & Fully RoHS Compliant
- ☑ Operating Bit Rate of 125Mb/s to 2.67Gb/s
- ☑ Compatible with SONET/SDH OC-48/STM-16
- ☑ Compatible with Gigabit Ethernet LX
- ☑ Compatible with Fibre Channel 200-SM-LC-L and 100-SM-LC-L
- ☑ Digital Diagnostics through Serial Interface
- ☑ Internal Calibration for Digital Diagnostics
- ☑ APD Receiver for Long Reach Applications
- ☑ Eye Safe (Class I Laser Safety)
- ☑ Duplex LC Optical Interface
- ☑ Hot-pluggable
- ☑ TX Fault & Loss of Signal Outputs
- ☑ TX Disable Input

Absolute Maximum Ratings

Parameter	Symbol	Minimum	Maximum	Units
Storage Temperature	T_{ST}	- 40	+ 85	°C
Operating Case Temperature ¹	"B" Option	- 5	+ 70	°C
	"A" Option	- 40	+ 85	
Supply Voltage	V_{CC}	0	+5.0	V
Maximum Input Optical Power (30 seconds max.)	$P_{in,max}$	-	+ 3.0	dBm
Input Voltage	V_{IN}	0	V_{CC}	V
Lead Terminal Finish, Reflow Profile Limits and MSL	-	-	NA	-

¹ Measured on top side of SFP module at the front center vent hole of the cage.

Transmitter Performance Characteristics (Over Operating Case Temperature. $V_{CC} = 3.13$ to $3.47V$)

Parameter		Symbol	Minimum	Typical	Maximum	Units
Operating Data Rate		B	0.125	-	2.67	Mb/s
Average Optical Output Power (coupled into single mode fiber), 50% duty cycle	SR-1	P_O	- 8.0	-	- 3.0	dBm
	IR-1, IR-2		- 5.0	-	0	
	LR-1, LR-2		- 2.0	-	+ 3.0	
Extinction Ratio	OC-3/12/48 & 2.125Gb/s	P_{hi}/P_{lo}	8.2	-	-	dB
	1.25Gb/s & 1.062Gb/s		9.0 ¹	-	-	
Center Wavelength	SR-1, IR-1	λ_c	1266	1310	1360	nm
	IR-2		1430	1550	1580	
	LR-1		1280	1310	1335	
	LR-2		1500	1550	1580	
Spectral Width (RMS)	SR-1	$\Delta\lambda_{RMS}$	-	-	2.4	nm
Spectral Width (-20dB)	IR-1, IR-2, LR-1, LR-2	$\Delta\lambda_{20}$	-	-	1.0	nm
Side Mode Suppression Ratio	IR-1, IR-2, LR-1, LR-2	$SMSR$	30	-	-	dB
Optical Rise/Fall Time (20% to 80%)		t_r, t_f	-	-	0.16	ns
Relative Intensity Noise		RIN	--	-	- 117	dB/Hz
Jitter Generation	OC-48	JG	-	-	0.07	Ulp-p
Dispersion Penalty	IR-1, IR-2, LR-1,	-	--	-	1.0	dB
	LR-2 ²		--	-	2.0	
Optical Output Eye		Compliant with Telcordia GR-253-CORE and ITU-T Recommendation G.957				
¹ Except for LR-2 which is 8.2dB minimum.						
² Specified at 1600ps/nm dispersion, which corresponds to the approximate worst-case dispersion for 80km G.652/G.654 fiber over the wavelength range of 1500-1580nm						

Receiver Performance Characteristics (Over Operating Case Temperature. $V_{CC} = 3.13$ to $3.47V$)

Parameter		Symbol	Minimum	Typical	Maximum	Units
Operating Data Rate		B	0.125	-	2.67	Gb/s
Receiver Sensitivity (10^{-10} BER) ¹	2.67Gb/s, OC-48	SR-1, IR-1, IR-2	- 19.0	-	-	dBm
		LR-1, LR-2	- 28.0	-	-	
	OC-3/12	- 23.0	-	-		
Receiver Sensitivity (10^{-12} BER) ²	2.125Gb/s, 1.25Gb/s, 1.062Gb/s	SR-1, IR-1, IR-2	- 20.0	-	-	dBm
		LR-1, LR-2	- 26.0	-	-	
	0.125Gb/s	- 23.0	-	-		
Maximum Input Optical Power (10^{-12} BER)	SR-1	P_{max}	- 3.0	-	-	dBm
	IR-1, IR-2		0	-	-	
	LR-1, LR-2		- 8.0	-	-	
LOS Thresholds	SR-1, IR-1, IR-2	Increasing Light Input	P_{los+}	-	- 23.0	dBm
		Decreasing Light Input	P_{los-}	- 35.0	-	
	LR-1, LR-2	Increasing Light Input	P_{los+}	-	- 28.0	
		Decreasing Light Input	P_{los-}	- 42.0	-	
LOS Timing Delay	Increasing Light Input	t_{loss_off}	-	-	100	μ s
	Decreasing Light Input	t_{loss_on}	2.3	-	100	
LOS Hysteresis		-	0.5 ³	-	-	dB
Wavelength of Operation		λ	1260	-	1600	nm
Receiver Reflectance		-	-	-	- 27.0	dB
¹ Measured with 2^{23} -1 PRBS.						
² Measured with 2^7 -1 PRBS.						
³ For OC-3, Minimum Hysteresis is 0.2dB.						

Transmitter Performance Characteristics (Over Operating Case Temperature. $V_{CC} = 3.13$ to $3.47V$)

Parameter	Symbol	Minimum	Typical	Maximum	Units
Input Voltage Swing (TD+ & TD-) ¹	V_{PP-DIF}	0.35	-	1.75	V
Input HIGH Voltage (TX Disable) ²	V_{IH}	2.0	-	V_{CC}	V
Input LOW Voltage (TX Disable) ²	V_{IL}	0	-	0.8	V
Output HIGH Voltage (TX Fault) ³	V_{OH}	2.0	-	$V_{CC} + 0.3$	V
Output LOW Voltage (TX Fault) ³	V_{OL}	0	-	0.8	V

¹ Differential peak-to-peak voltage.
² There is an internal 4.7 to 10kΩ pull-up resistor to V_{CC} T.
³ Open collector compatible, 4.7 to 10kΩ pull-up resistor to V_{CC} (Host Supply Voltage).

Receiver Electrical Interface (Over Operating Case Temperature. $V_{CC} = 3.13$ to $3.47V$)

Parameter	Symbol	Minimum	Typical	Maximum	Units
Output Voltage Swing (RD+ & RD-) ¹	V_{PP-DIF}	0.40	-	1.75	V
Output HIGH Voltage (LOS) ²	V_{OH}	$V_{CC} - 1.3$	-	$V_{CC} + 0.3$	V
Output LOW Voltage (LOS) ²	V_{OL}	0	-	0.5	V

¹ Differential peak-to-peak voltage across external 100Ω load.
² Open collector compatible, 4.7 to 10kΩ pull-up resistor to V_{CC} (Host Supply Voltage).

Electrical Power Supply Characteristics (Over Operating Case Temperature. $V_{CC} = 3.13$ to $3.47V$)

Parameter	Symbol	Minimum	Typical	Maximum	Units
Supply Voltage	V_{CC}	3.13	3.3	3.47	V
Supply Current	SR-1, IR-1, IR-2	-	175	295	mA
	LR-1, LR-2	-	175	350	

Module Definition

MOD_DEF(0) pin 6	MOD_DEF(1) pin 5	MOD_DEF(2) pin 4	Interpretation by Host
TTL LOW	SCL	SDA	Serial module definition protocol

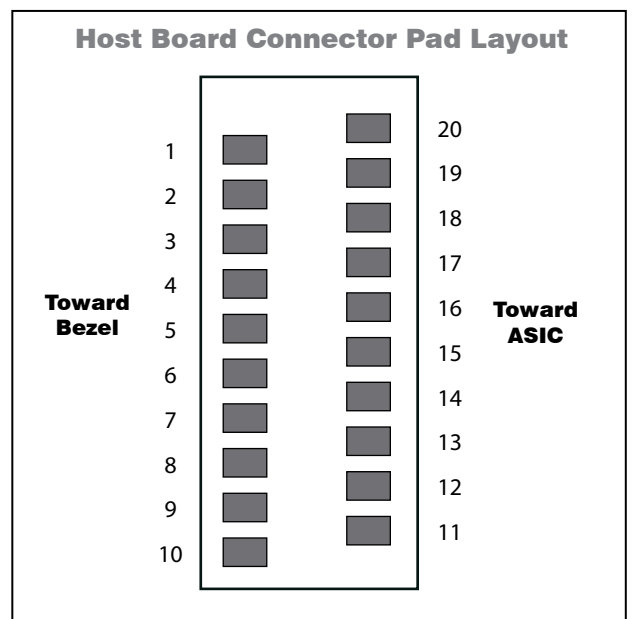
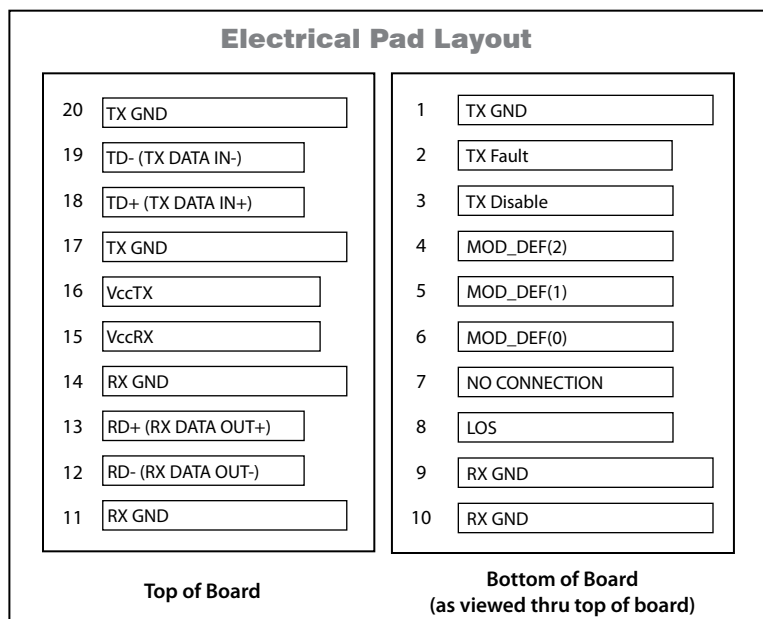

Example of SFP host board schematic

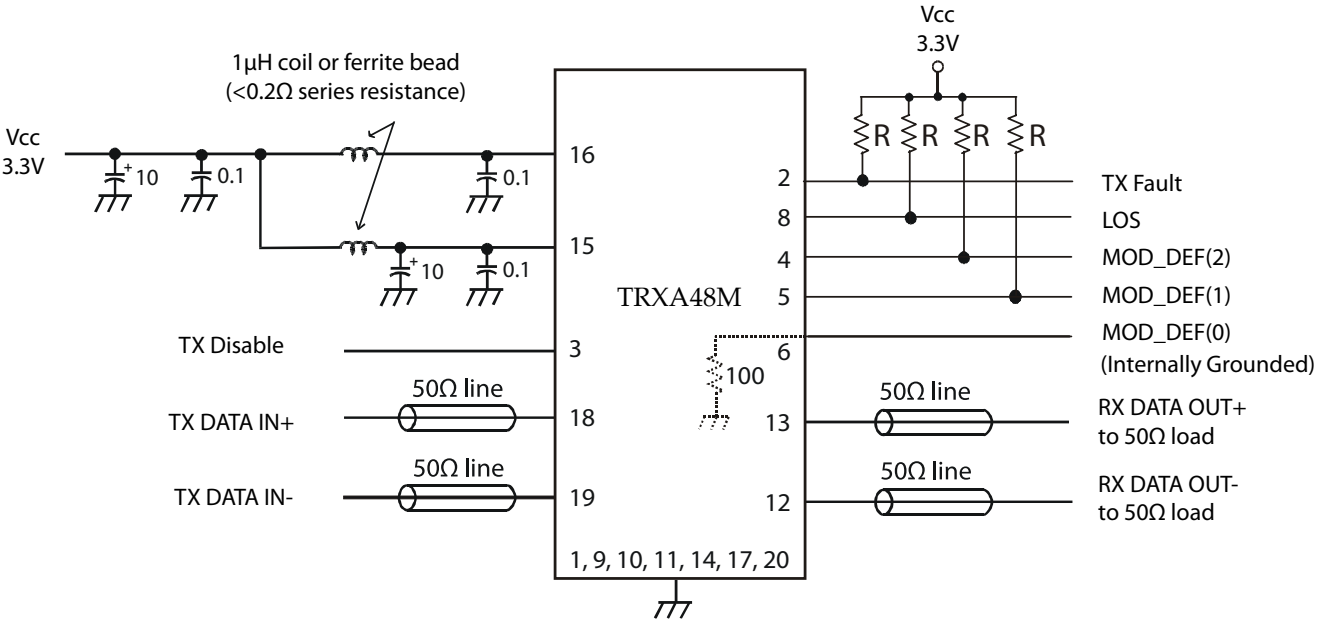

R: 4.7 to 10kΩ

Application Notes

Electrical interface: All signal interfaces are compliant with the SFP MSA specification. The high speed DATA interface is differential AC-coupled internally with 0.1µF and can be directly connected to a 3.3V SERDES IC. All low speed control and sense output signals are open collector TTL compatible and should be pulled up with a 4.7 - 10kΩ resistor on the host board

Loss of Signal (LOS): The Loss of Signal circuit monitors the level of the incoming optical signal and generates a logic HIGH when an insufficient photocurrent is produced.

TX Fault: The output indicates LOW when the transmitter is operating normally, and HIGH with a laser fault including laser end-of-life. TX Fault is an open collector/drain output and should be pulled up with a 4.7 - 10kΩ resistor on the host board. TX Fault in non-latching (automatically deasserts when fault goes away).

TX Disable: When the TX Disable pin is at logic HIGH, the transmitter optical output is disabled (less than -45dBm).

Serial Identification and Monitoring: The module definition of SFP is indicated by the three module definition pins, MOD_DEF(0), MOD_DEF(1) and MOD_DEF(2).

Laser Safety

Laser Safety: All transceivers are Class I Laser products per FDA/CDRH and IEC-60825 standards. They must be operated under specified operating conditions.

Upon power up, MOD_DEF(1:2) appear as NC (no connection), and MOD_DEF(0) is TTL LOW. When the host system detects this condition, it activates the serial protocol (standard two-wire I²C serial interface) and generates the serial clock signal (SCL). The positive edge clocks data into the EEPROM segments of the SFP that are not write protected, and the negative edge clocks data from the SFP.

The serial data signal (SDA) is for serial data transfer. The host uses SDA in conjunction with SCL to mark the start and end of serial protocol activation. The supported monitoring functions are internal temperature, supply voltage, bias current, transmitter power, average receiver signal, all alarms and warnings and software monitoring of TX Fault/LOS. The device is internally calibrated.

The data transfer protocol and the details of the mandatory and vendor specific data structures are defined in the SFPMSA, and SFF-8472, Rev. 9.4

Power supply and grounding: The power supply line should be well-filtered. All 0.1µF power supply bypass capacitors should be as close to the transceiver module as possible.

Oplink Communications, Inc.
DATE OF MANUFACTURE:



This product complies with
21 CFR 1040.10 and 1040.11

Meets Class I Laser Safety Requirements



Package Outline

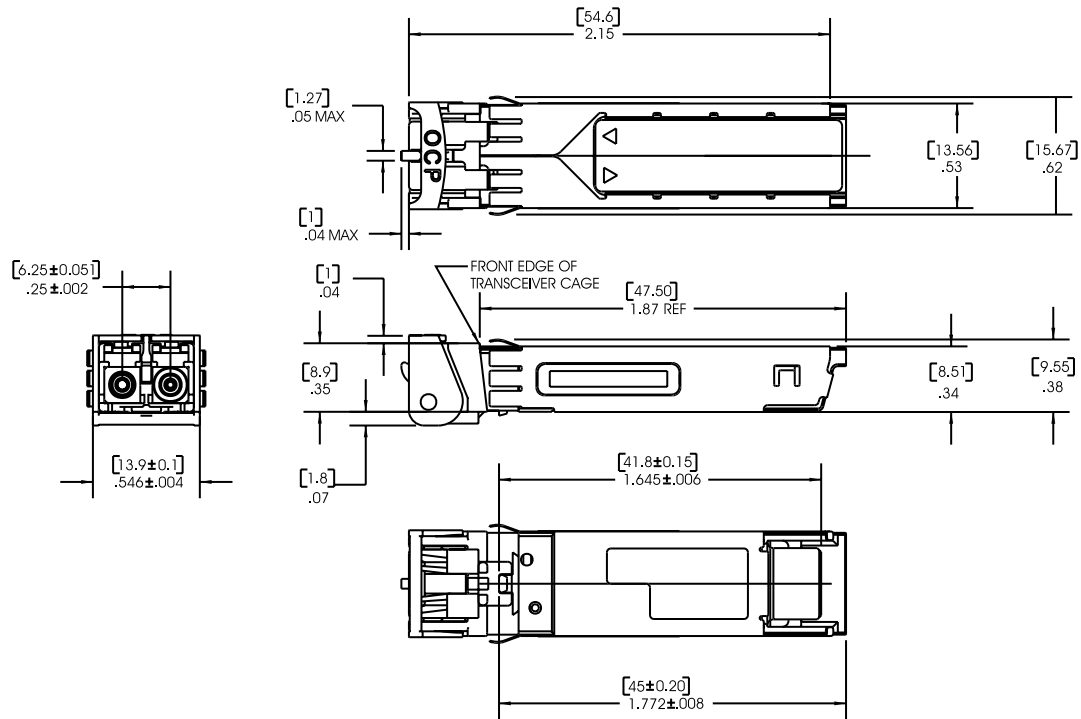

Dimensions in inches [mm]
Default tolerances:
.xxx = ± .005", .xx = ± .01"

Ordering Information

Oplink can provide a remarkable range of customized optical solutions. For detail, please contact Oplink's Sales and Marketing for your requirements and ordering information (510) 933-7200 or Sales@oplink.com.