

D/808A/6 September 2003

### 1.0 Features

- Unique CTCSS 'Type 2' Operation
- Fast Decode on all Tones (140ms)
- Tones from 60Hz to 251Hz
- Tone Cloning
- Low Power Operation (1.3mA at 3.0V)
- High Performance Encode/Decode
- Flexible Multiple Decode Options
- Sub-Audio Tone Rejection Filter
- 48 Programmable CTCSS Tones
- Compact 20-pin TSSOP Package

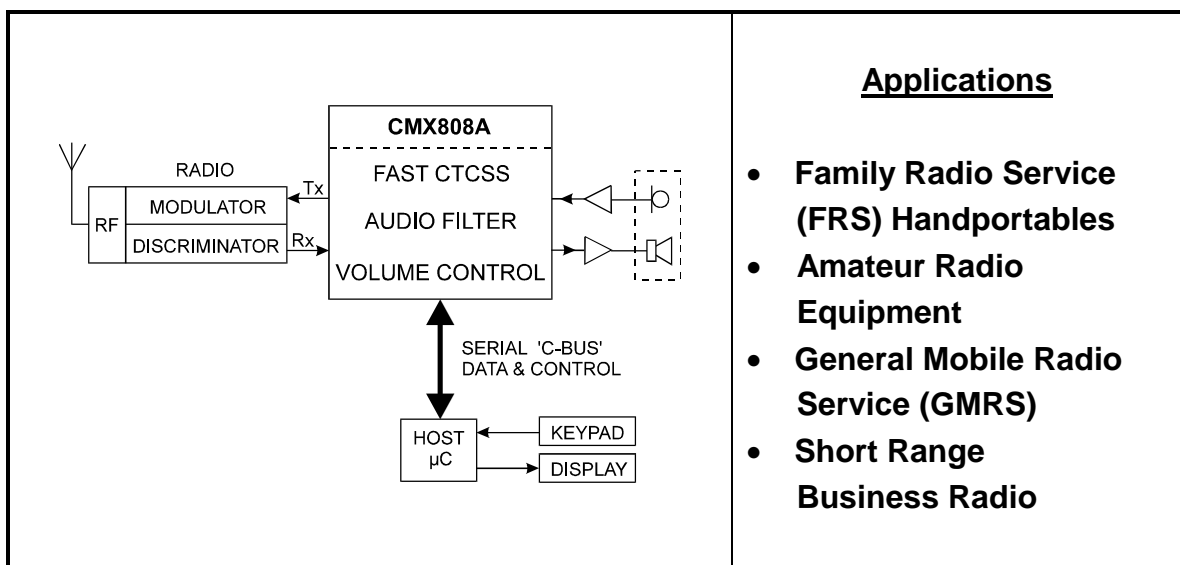

### 1.1 Brief Description

This device is a unique product for the designer of family radio transceivers. Offering leading edge performance while also being highly cost effective. The device is simple to interface to a host of  $\mu$ Controllers via the serial programming interface. A full range of 48 tones can be generated and detected by the device. The decode time has been vastly improved from that offered by other solutions. Fast response and de-response gives the user of a family radio transceiver faster switching times and a reduction in the annoying squelch tail often found in CTCSS based systems. The device has very low power consumption operating at a minimum of 3.0V.

A unique feature of the device is its ability to look for 7 different CTCSS codes simultaneously. This allows FRS designers to offer equipment which can look for personal, family or open channel codes at the same time. For example a soccer team coach can call each of the 11 players individually or the team as a group. Codes can be used as Paging codes, open chat mode codes as well as personal and family codes. These features allow FRS designers to differentiate their products from that of the competition in unique ways to gain market share in this highly competitive application. The CMX808A opens the way to rapid development of new family radio applications.

---

<u>Section</u>	<b>CONTENTS</b>	<u>Page</u>
<b>1.0</b>	<b>Features .....</b>	<b>1</b>
<b>1.2</b>	<b>Block Diagram .....</b>	<b>3</b>
<b>1.3</b>	<b>Signal List .....</b>	<b>4</b>
<b>1.4</b>	<b>External Components .....</b>	<b>6</b>
<b>1.5</b>	<b>General Description .....</b>	<b>7</b>
1.5.1	Software Description .....	7
<b>1.6</b>	<b>Application Notes .....</b>	<b>14</b>
1.6.1	General .....	14
1.6.2	Transmitter .....	14
1.6.3	Receiver (Decode) .....	14
1.6.4	Tx Tone Table .....	15
1.6.5	Rx Tone Table .....	16
<b>1.7</b>	<b>Performance Specification .....</b>	<b>17</b>
1.7.1	Electrical Performance .....	17
1.7.2	Packaging .....	21

## 1.2 Block Diagram

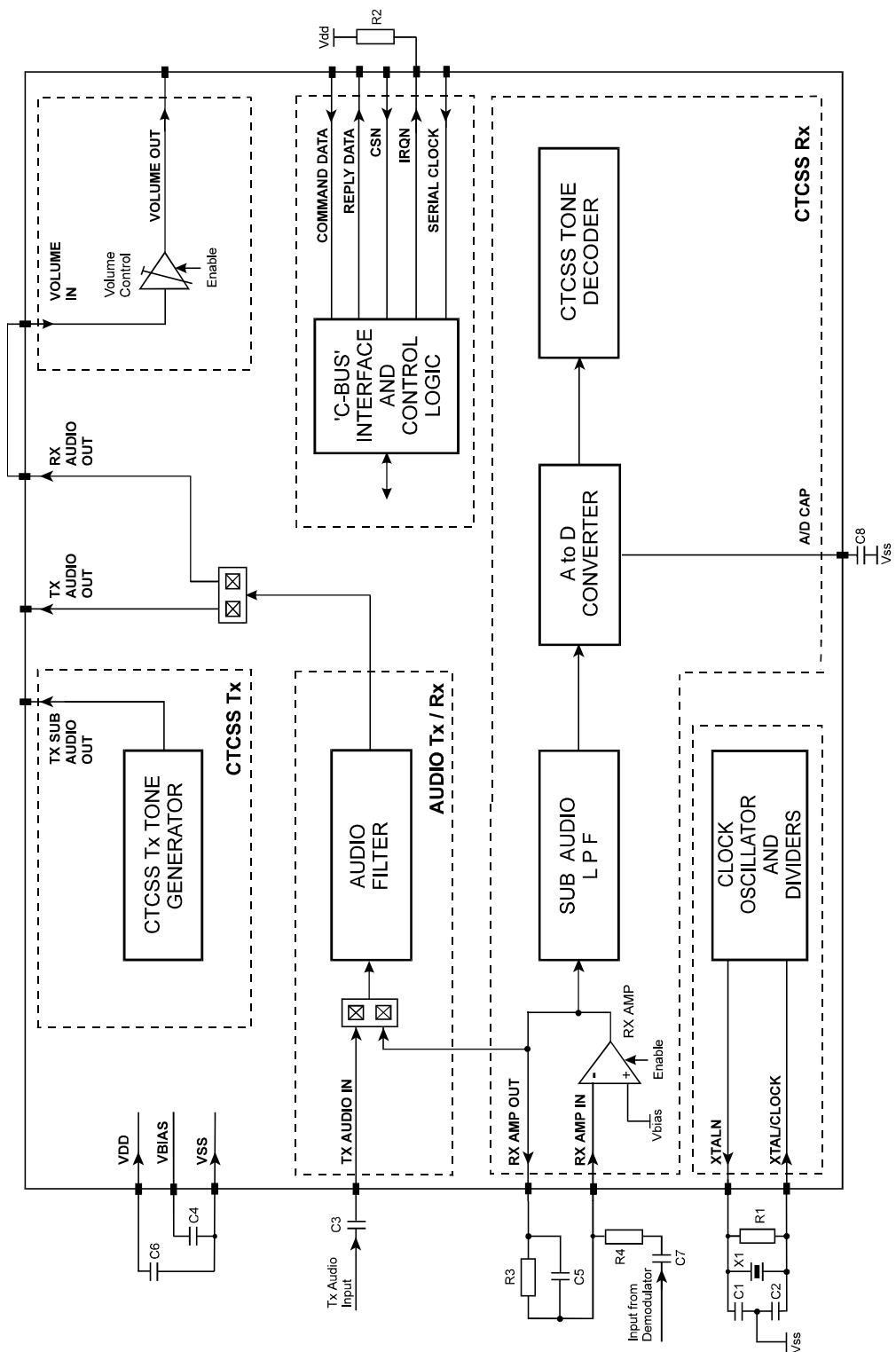

Figure 1 Block Diagram

### 1.3 Signal List

Package		Signal		Description
E3	P4			
Pin No.	Pin No.	Name	Type	
1	1	XTALN	O/P	The inverted output of the on-chip oscillator.
2	2	XTAL/CLOCK	I/P	The input to the on-chip oscillator, for external Xtal circuit or clock.
3	3	SERIAL CLOCK	I/P	The "C-BUS" serial clock input. This clock, produced by the $\mu$ Controller, is used for transfer timing of commands and data to and from the device. See "C-BUS" Timing Diagram (Figure 4).
4	4	COMMAND DATA	I/P	The "C-BUS" serial data input from the $\mu$ Controller. Data is loaded into this device in 8-bit bytes, MSB (D7) first, and LSB (D0) last, synchronised to the SERIAL CLOCK. See "C-BUS" Timing Diagram (Figure 4).
5	5	REPLY DATA	O/P	The "C-BUS" serial data output to the $\mu$ Controller. The transmission of REPLY DATA bytes is synchronised to the SERIAL CLOCK under the control of the CSN input. This 3-state output is held at high impedance when not sending data to the $\mu$ Controller. See "C-BUS" Timing Diagram (Figure 4).
6	6	CSN	I/P	The "C-BUS" data loading control function: this input is provided by the $\mu$ Controller. Data transfer sequences are initiated, completed or aborted by the CSN signal. See "C-BUS" Timing Diagram (Figure 4).
7	7	IRQN	O/P	This output indicates an interrupt condition to the $\mu$ Controller by going to a logic "0". This is a "wire-ORable" output, enabling the connection of up to 8 peripherals to 1 interrupt port on the $\mu$ Controller. This pin has a low impedance pulldown to logic "0" when active and a high-impedance when inactive. An external pullup resistor is required.  An interrupt is effective if not masked out by the IRQ MASK (bit 0 in the SUB-AUDIO CONTROL register \$80).

### 1.3 Signal List (continued)

Package		Signal		Description
E3	P4	Name	Type	
8	8 9	NC NC		) No internal connection. Do not make ) any connection to these pins.
9	10	A/D CAP	O/P	An internal reference voltage for the A to D, decoupled to $V_{SS}$ by an external capacitor.
	11	NC		No internal connection. Do not make any connection to this pin.
10	12	$V_{SS}$	Power	The negative supply rail (ground).
11	13	$V_{BIAS}$	O/P	A bias line for the internal circuitry, held at $\frac{1}{2} V_{DD}$ . This pin must be decoupled by a capacitor mounted close to the device pins.
12	14	RX AMP IN	I/P	The inverting input to the Rx input amplifier.
13	15	RX AMP OUT	O/P	The output of the Rx input amplifier and the input to the audio filter section.
14	16	RX AUDIO OUT	O/P	Output of the Rx audio filter section.
	17	NC		No internal connection. Do not make any connection to this pin.
15	18	TX AUDIO IN	I/P	Input to the Tx audio filter section.
16	19	TX AUDIO OUT	O/P	Output of the Tx audio filter section.
17	20	VOLUME IN	I/P	Input to the audio volume control.
18	21	TX SUB AUDIO OUT	O/P	Output of the CTCSS tone generator.
19	22	VOLUME OUT	O/P	Output of the audio volume control.
	23	NC		No internal connection. Do not make any connection to this pin.
20	24	$V_{DD}$	Power	The positive supply rail. Levels and voltages are dependent upon this supply. This pin should be decoupled to $V_{SS}$ by a capacitor.

**Notes:** I/P = Input  
O/P = Output

### 1.4 External Components

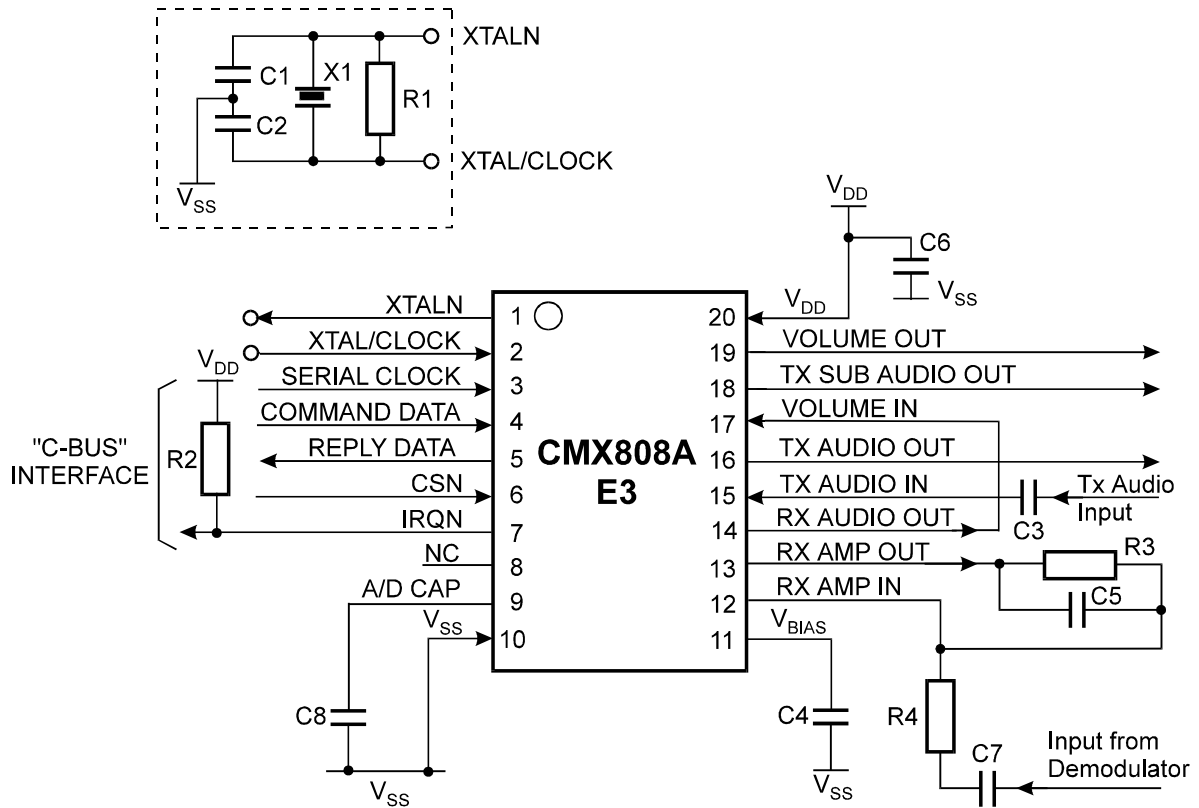

C1	22pF	±20%	R1	1MΩ	±5%
C2	22pF	±20%	R2	22kΩ	±10%
C3	0.1µF	±20%	R3	100kΩ	±10%
C4	0.1µF	±20%	R4	Note 1	±10%
C5	100pF	±20%			
C6	0.1µF	±20%			
C7	Note 1	±20%			
C8	0.1µF	±20%	X1	4.0MHz	±100ppm

**Note:** 1. R3, R4, C5 and C7 form the gain components for the Rx Input Amplifier. R4 should be chosen as required by the signal level, using the following formula:

$$\text{Gain} = - \frac{R3}{R4}$$

C7 x R4 should be chosen so as not to compromise the low frequency performance of this product.

**Figure 2 Recommended External Components**

## 1.5 General Description

The CMX808A is a programmable CTCSS 'Type 2' encoder and decoder for Family Radio, see Figure 1.

The receiver of the CMX808A decodes a user-programmable set of up to 7 tones with minimum software intervention; the band-pass filter is designed to filter out the CTCSS sub-audio tones. A high resolution tone encoder performs accurate generation of CTCSS tones.

Each function, and the routing of signals, is flexible and may be configured or controlled by the user's software.

### 1.5.1 Software Description

#### Address/Commands

Instructions and data are transferred, via "C-BUS", in accordance with the timing information given in Figure 6.

Instruction and data transactions to and from the CMX808A consist of an Address/Command (A/C) byte which may be followed by either:

- (i) a further instruction or data (1 or 2 bytes) or
- (ii) a status or Rx data reply (1 byte)

#### 8-bit Write Only Registers

HEX ADDRESS/COMMAND	REGISTER NAME	BIT 7 (D7)	BIT 6 (D6)	BIT 5 (D5)	BIT 4 (D4)	BIT 3 (D3)	BIT 2 (D2)	BIT 1 (D1)	BIT 0 (D0)
\$01	GENERAL RESET	N/A	N/A	N/A	N/A	N/A	N/A	N/A	N/A
\$80	SUB-AUDIO CONTROL	CTCSS		CTCSS DECODER BANDWIDTH				0	CTCSS IRQ MASK
		TX ENABLE	DECODER ENABLE	MSB BIT 3	BIT 2	BIT 1	LSB BIT 0		
\$82	AUDIO CONTROL	TX BPF ENABLE	RX BPF ENABLE	BPF UN-MUTE	AUDIO ATTENUATION				
					MSB BIT 4	BIT 3	BIT 2	BIT 1	LSB BIT 0

#### 16-bit Write Only Registers

HEX ADDRESS/COMMAND	REGISTER NAME	BIT 7 (D7)	BIT 6 (D6)	BIT 5 (D5)	BIT 4 (D4)	BIT 3 (D3)	BIT 2 (D2)	BIT 1 (D1)	BIT 0 (D0)
\$83	CTCSS TX FREQ. (Byte 1)	CTCSS TX NOTONE	0	0	CTCSS TX FREQUENCY				
					MSB BIT 12	BIT 11	BIT 10	BIT 9	BIT 8
	CTCSS TX FREQ. (Byte 2)	CTCSS TX FREQUENCY							
\$84	CTCSS RX PROGRAM (Byte 1)	0	CTCSS TONE ADDRESS			CTCSS FREQUENCY			
			MSB BIT 2	BIT 1	LSB BIT 0	MSB BIT 11	BIT 10	BIT 9	BIT 8
	CTCSS RX PROGRAM (Byte 2)	CTCSS FREQUENCY							
		BIT 7	BIT 6	BIT 5	BIT 4	BIT 3	BIT 2	BIT 1	LSB BIT 0

## Write Only Register Description

### GENERAL RESET (Hex address \$01)

The reset command has no data attached to it. It sets the device registers to zero (all powersaved) with the exception of Bits 2, 1 and 0 of the SUB-AUDIO STATUS register \$81.

### SUB-AUDIO CONTROL Register (Hex address \$80)

This register is used to control the functions of the device as described below:

#### CTCSS TX ENABLE and DECODER ENABLE (Bits 7 and 6)

These two bits enable and disable the CTCSS decoder (Rx) or transmitter (Tx) according to the table below:

Tx Bit 7	Rx Bit 6	Function
0	0	Tx disabled, Rx disabled
0	1	Tx disabled, Rx enabled
1	0	Tx enabled, Rx disabled
1	1	Tx enabled, Rx enabled

#### CTCSS DECODER BANDWIDTH (Bits 5, 4, 3 and 2)

These four bits set the bandwidth of the CTCSS tone decoder according to the table below:

Bit 5	Bit 4	Bit 3	Bit 2	BANDWIDTH	
				Will Decode	Will Not Decode
1	0	0	0	±1.1%	±2.4%
1	0	0	1	±1.3%	±2.7%
1	0	1	0	±1.6%	±2.9%
1	0	1	1	±1.8%	±3.2%
1	1	0	0	±2.0%	±3.5%
1	1	0	1	±2.2%	±3.7%
1	1	1	0	±2.5%	±4.0%
1	1	1	1	±2.7%	±4.2%

#### (Bit 1)

Reserved for future use. This bit should be set to "0".

#### CTCSS IRQ MASK (Bit 0)

When this bit is set to "1" it enables the interrupt. When this bit is set to "0" the interrupt is masked.

### AUDIO CONTROL Register (Hex address \$82)

This register is used to control the functions of the device as described below:

Note: TX BPF ENABLE (Bit 7) and RX BPF ENABLE (Bit 6) should not be enabled at the same time.

#### TX BPF ENABLE (Bit 7)

When this bit is "1" the audio band-pass filter is enabled and the output of the filter is switched to TX AUDIO OUT. The output is then controlled by BPF UNMUTE. See Bit 5 below.

When this bit is "0" the audio band pass filter is disabled (powersaved) and the output of the filter is disconnected from TX AUDIO OUT, which is then in a high impedance state.



**RX BPF ENABLE  
(Bit 6)**

When this bit is “1” the audio band-pass filter is enabled and the output of the filter is switched to RX AUDIO OUT. The output is then controlled by BPF UN-MUTE. See Bit 5 below.

When this bit is “0” the audio band-pass filter is disabled (powersaved) and the output of the filter is disconnected from RX AUDIO OUT, which is then in a high impedance state.

**BPF UN-MUTE  
(Bit 5)**

When this bit is “1” and TX BPF ENABLE is “1” the audio band-pass filter output is switched to the TX AUDIO OUT pin. When this bit is “0” the output of the filter is disconnected from TX AUDIO OUT, which is then in a high impedance state. This control, along with TX BPF ENABLE, allows the filter to power up and settle internally before switching the output on, when coming out of powersave.

When this bit is “1” and RX BPF ENABLE is “1” the audio band-pass filter output is switched to the RX AUDIO OUT pin. When this bit is “0” the output of the filter is disconnected from RX AUDIO OUT, which is then in a high impedance state. This control, along with RX BPF ENABLE, allows the filter to power up and settle internally before switching the output on, to avoid clicks when coming out of powersave.

**AUDIO ATTENUATION  
(Bits 4, 3, 2, 1, and 0)**

These five bits are used to set the attenuation of the audio volume control according to the table below:

Bits					Audio Attenuation
4	3	2	1	0	
0	0	0	0	0	Off ( $V_{BIAS}$ )
0	0	0	0	1	48.0dB
0	0	0	1	0	46.4dB
0	0	0	1	1	44.8dB
0	0	1	0	0	43.2dB
0	0	1	0	1	41.6dB
0	0	1	1	0	40.0dB
0	0	1	1	1	38.4dB
0	1	0	0	0	36.8dB
0	1	0	0	1	35.2dB
0	1	0	1	0	33.6dB
0	1	0	1	1	32.0dB
0	1	1	0	0	30.4dB
0	1	1	0	1	28.8dB
0	1	1	1	0	27.2dB
0	1	1	1	1	25.6dB
1	0	0	0	0	24.0dB
1	0	0	0	1	22.4dB
1	0	0	1	0	20.8dB
1	0	0	1	1	19.2dB
1	0	1	0	0	17.6dB
1	0	1	0	1	16.0dB
1	0	1	1	0	14.4dB
1	0	1	1	1	12.8dB
1	1	0	0	0	11.2dB
1	1	0	0	1	9.6dB
1	1	0	1	0	8.0dB
1	1	0	1	1	6.4dB
1	1	1	0	0	4.8dB
1	1	1	0	1	3.2dB
1	1	1	1	0	1.6dB
1	1	1	1	1	0dB

**CTCSS TX FREQUENCY Register (Hex address \$83)**

This is a 16-bit register. Byte (1) is sent first. When the CTCSS transmitter is enabled, the bits 0 to 12 control the frequency of the transmitted CTCSS tones according to the formula below.

$$A = \frac{f_{XTAL} \text{ (Hz)}}{16 \times f_{TONE} \text{ (Hz)}}$$

where A is the binary number programmed into the 13 bits.

When Bit 7 (in the first 8 bits) is set to "1" the tone output is set at  $V_{BIAS}$  or NOTONE without regard to the number "A" programmed. When Bit 7 is "0" the programmed tone is set on the output. Programming bits 0 to 12 to "0" sets the output to  $V_{BIAS}$ . Powersave is achieved by disabling the Tx (Bit 7 in the SUB-AUDIO CONTROL register \$80).

**CTCSS RX PROGRAM Register (Hex address \$84)**

This is a 16-bit register. Byte (1) is sent first. The two bytes are used to program the centre frequencies of up to 7 tones in the sub-audio band that will be decoded by the receiver.

Each tone is identified by its address in Bits 6, 5 and 4 of byte (1). The remaining 12 bits contain the data representing the tone frequency according to the formula below. If a tone is not required the 12 bits should be set to zero.

Byte 1								Byte 2							
Bit 7	Bit 6	Bit 5	Bit 4	Bit 3	Bit 2	Bit 1	Bit 0	Bit 7	Bit 6	Bit 5	Bit 4	Bit 3	Bit 2	Bit 1	Bit 0
0	0	0	0	<----- N ----->				<----- R ----->							
0	0	0	1	N is the binary representation of the following decimal number (n): $n = \text{INT} (948982 \times f_{TONE} / f_{XTAL})$				R is the nearest 6-bit binary representation of (r), where: $r = ((237245 / f_{XTAL}) - (n / (4 \times f_{TONE}))) \times 8400$							
0	0	1	0												
0	0	1	1												
0	1	0	0												
0	1	0	1												
0	1	1	0												

Example: To program 100Hz when using the recommended 4.0MHz Xtal.

$$\begin{aligned} n &= \text{INT} (948982 \times 100 / 4.0 \times 10^6) \\ &= \text{INT} (23.72) = 23 \end{aligned}$$

$$\therefore N = 010111 \text{ (binary)}$$

$$\begin{aligned} r &= ((237245 / 4.0 \times 10^6) - (23 / (4 \times 100))) \times 8400 \\ &= 15.21 \text{ (round up if exactly halfway)} \\ &= 15 \end{aligned}$$

$$\therefore R = 001111 \text{ (binary)}$$

Thus the 12-bit code is 010111001111.

The Hex address represented by Bits 6, 5 and 4 in byte (1) is used as the code to indicate which tone has been decoded. This code appears in Bits 2, 1 and 0 of the SUB-AUDIO STATUS register \$81. The 7 programmed tones use Hex addresses \$0 - \$6. Address \$7 should not be used.

**TONE CLONING Register (Hex address \$9C)**

This register enables and disables tone cloning as shown below:

- \$9C = \$01 enables tone cloning.
- \$9C = \$00 disables tone cloning.

Figure 4 shows the tone cloning routine.

**8-bit Read Only Registers**

HEX ADDRESS/COMMAND	REGISTER NAME	BIT 7 (D7)	BIT 6 (D6)	BIT 5 (D5)	BIT 4 (D4)	BIT 3 (D3)	BIT 2 (D2)	BIT 1 (D1)	BIT 0 (D0)
\$81	SUB-AUDIO STATUS	0	0	0	0	TONE DECODE	CTCSS RX TONE		
							MSB BIT 2	BIT 1	LSB BIT 0

**Read Only Register Description****SUB-AUDIO STATUS Register (Hex address \$81)**

Reading the SUB-AUDIO STATUS register clears the interrupt (IRQN).

This register is used to indicate the status of the device as described below:

**(Bits 7, 6, 5 and 4)** Reserved for future use. These will be set to "0" but should be ignored by user's software.

**TONE DECODE (Bit 3)** This bit indicates the status of the tone decoder. A "1" indicates a tone has been detected (TONE DECODE) and a "0" indicates the loss of the tone (NOTONE).

TONE DECODE means that a tone has been decoded and its characteristics are defined by the bandwidth (see SUB-AUDIO CONTROL register \$80, Bits 5, 4, 3 and 2) and the CTCSS RX TONE number (see SUB-AUDIO STATUS register \$81, Bits 2, 1 and 0).

When Bit 6 in the SUB-AUDIO CONTROL register \$80 is set to "0" the TONE DECODE Bit 3 will be set to "0".

Identification of a valid tone which is not in the pre-programmed list of up to 7 tones will cause the decoder to move to the TONE DECODE state with the RX TONE address of "111" in Bits 2, 1 and 0; indicating a valid but unrecognised tone. Loss of tone will cause the NOTONE timer to be started. If loss of tone continues for the duration of the time-out period, then the decoder will move to NOTONE state and the identification of pre-programmed tones will start again. The time-out period is not user adjustable.

**CTCSS RX TONE (Bits 2, 1 and 0)**

These three bits hold a Hex number. Numbers \$0 to \$6 represent the address of the CTCSS tone decoded according to the tones programmed in the CTCSS RX PROGRAM register \$84. The Hex number \$7 indicates the presence of any tone that is not described by CTCSS DECODER BANDWIDTH (Bits 5, 4, 3 and 2 in the SUB-AUDIO CONTROL register \$80) and CTCSS FREQUENCY (Bits 11 to 0 in the CTCSS RX PROGRAM register \$84).

The flow chart shows the decoder and transmitter modes of operation for the example below:

1. Decoder, e.g. Address 0 = 100Hz, bandwidth =  $\pm 2.7\%$ , interrupt enabled.
2. Transmitter, e.g. Tx = 100Hz.

Note: \$8X is the Hex address/command.

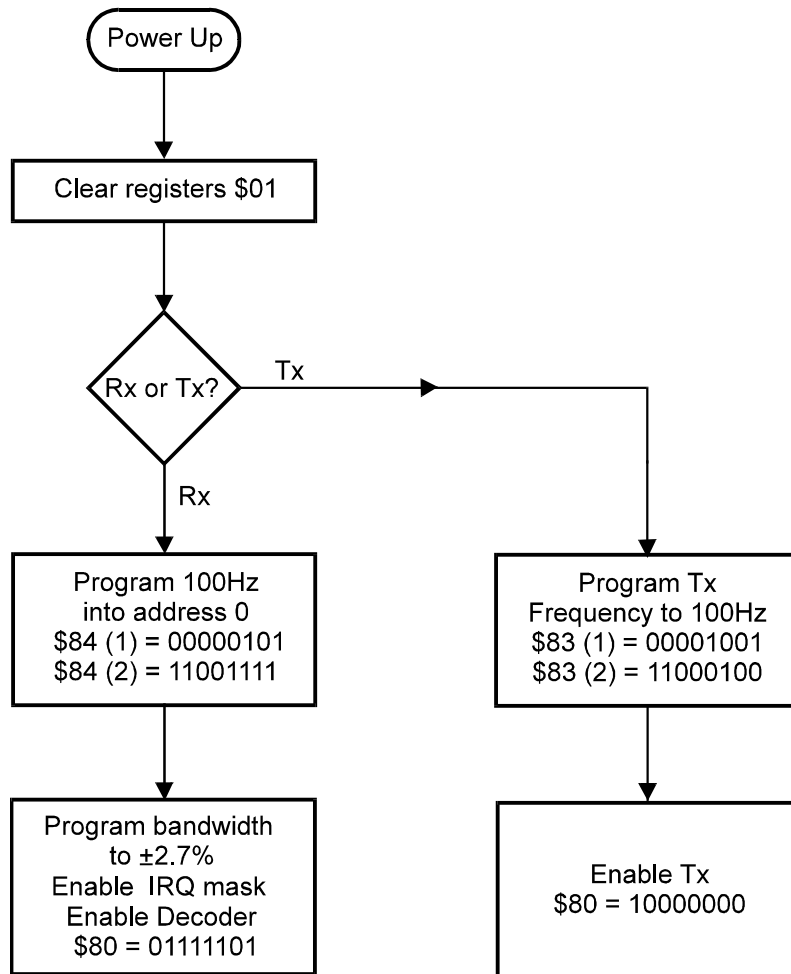

**Figure 3 Tx/Rx enabled**

The flow chart shows the tone cloning routine. The first programmed tone set (\$0-\$6) will decode after typically 140ms, subsequent tone sets will decode almost instantly (i.e. the information is available at the Reply Data Output in less than 100µs).

Note: \$8X and \$9C is the Hex address/command.

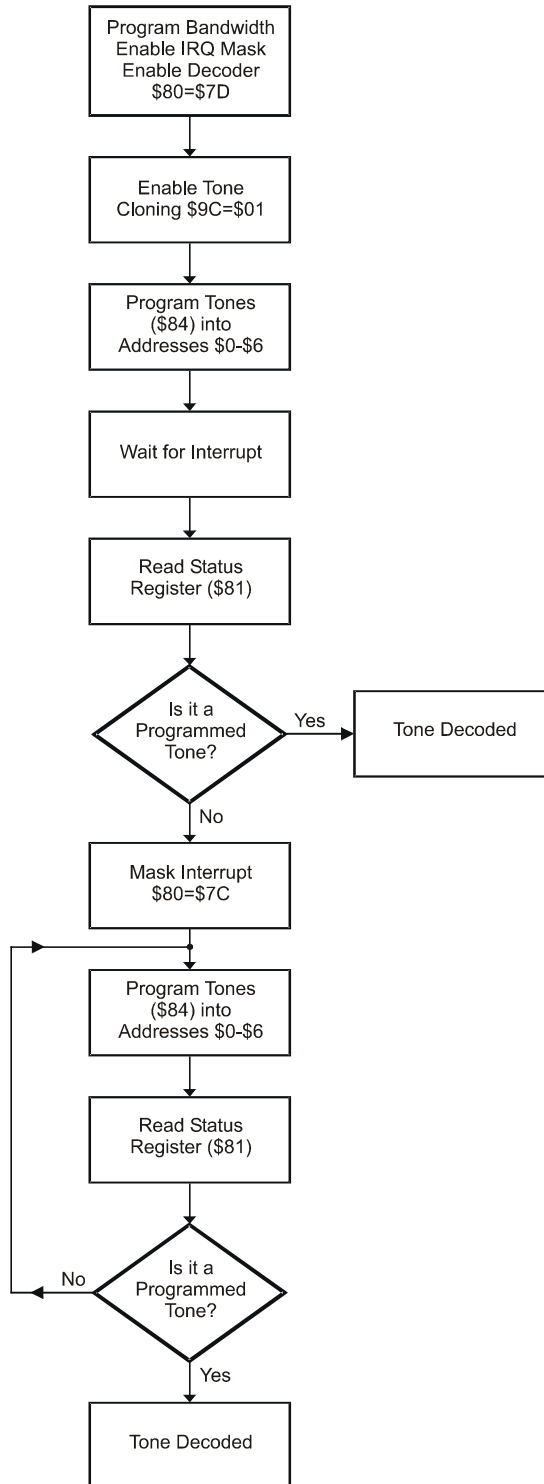

**Figure 4 Tone Cloning**

## 1.6 Application Notes

### 1.6.1 General

The CMX808A is intended for use in radio systems where sub-audio signalling is required for functions such as Family Radio Service (FRS) Handportables, Amateur Radio Equipment, General Mobile Radio Service (GMRS) and Short Range Business Radio.

The facility to decode any of up to 7 programmed tones allows FRS designers to offer equipment which can look for personal, family or open channel codes at the same time. Codes can be used as paging codes, open chat mode codes as well as personal and family codes.

Adjustable decoder bandwidths permits certainty and signal to noise performance to be traded when congestion or range limits the system performance.

### 1.6.2 Transmitter

The transmitter is enabled with Bit 7 in the SUB-AUDIO CONTROL register \$80.

The Tx frequency is set using bits 0 to 12 in the CTCSS TX FREQUENCY register \$83, using the formula below:

$$A = \frac{f_{XTAL} \text{ (Hz)}}{16 \times f_{TONE} \text{ (Hz)}}$$

where A is the binary number programmed into the 13 bits.

When Bit 7 (in the first 8 bits) is set to "1" the tone output is set at  $V_{BIAS}$  or NOTONE without regard to the number "A" programmed. When Bit 7 is "0" the programmed tone is set on the output. Programming bits 0 to 12 to "0" sets the output to  $V_{BIAS}$ . Powersave is also achieved by disabling the Tx (Bit 7 in the SUB-AUDIO CONTROL register \$80).

### 1.6.3 Receiver (Decode)

The CTCSS Receiver (Decoder) should first be set up according to the desired characteristics. This entails setting the CTCSS DECODER BANDWIDTH in the SUB-AUDIO CONTROL register \$80, also programming the centre frequencies of the desired tones in the CTCSS RX PROGRAM register \$84. (It can hold up to 7 different tones). Any tone can be in any location. During operation when the device is receiving, the tones are scanned in the sequence of their location, i.e. \$0 first and \$6 last and once a tone is detected the remaining tones are not checked. Therefore if two tones are close enough in frequency for their bandwidths to overlap then the one in the lowest location will be detected.

The CTCSS IRQ MASK in the SUB-AUDIO CONTROL register \$80 should also be set as required.

The CTCSS DECODER ENABLE in the SUB-AUDIO CONTROL register \$80 should then be set to "1".

The TONE CLONING register \$9C should be set as required.

When the receiver detects a change in its present state an interrupt will be generated. The change that occurred can be read from Bit 3 of the SUB-AUDIO STATUS register \$81 and if a tone is indicated by these bits then the number of that tone can be read from Bits 2, 1 and 0 of the same register. The interrupt is cleared by reading the SUB-AUDIO STATUS register.

#### 1.6.4 Tx Tone Table

The following table lists the commonly used CTCSS tones and the corresponding values for programming the CTCSS TX FREQUENCY register \$83.

STANDARD TONES								
Freq. (Hz)	Byte 1 (Hex)	Byte 2 (Hex)	Freq. (Hz)	Byte 1 (Hex)	Byte 2 (Hex)	Freq. (Hz)	Byte 1 (Hex)	Byte 2 (Hex)
<b>67.0</b>	0E	93	<b>103.5</b>	09	6F	<b>162.2</b>	06	05
<b>69.3</b>	0E	18	<b>107.2</b>	09	1C	<b>167.9</b>	05	D1
<b>71.9</b>	0D	95	<b>110.9</b>	08	CE	<b>173.8</b>	05	9E
<b>74.4</b>	0D	20	<b>114.8</b>	08	82	<b>179.9</b>	05	6E
<b>77.0</b>	0C	AF	<b>118.8</b>	08	38	<b>186.2</b>	05	3F
<b>79.7</b>	0C	41	<b>123.0</b>	07	F1	<b>192.8</b>	05	11
<b>82.5</b>	0B	D6	<b>127.3</b>	07	AC	<b>203.5</b>	04	CD
<b>85.4</b>	0B	6F	<b>131.8</b>	07	69	<b>210.7</b>	04	A3
<b>88.5</b>	0B	09	<b>136.5</b>	07	28	<b>218.1</b>	04	7A
<b>91.5</b>	0A	AC	<b>141.3</b>	06	E9	<b>225.7</b>	04	54
<b>94.8</b>	0A	4D	<b>146.2</b>	06	AE	<b>233.6</b>	04	2E
<b>97.4</b>	0A	07	<b>151.4</b>	06	73	<b>241.8</b>	04	0A
<b>100.0</b>	09	C4	<b>156.7</b>	06	3B	<b>250.3</b>	03	E7

NON-STANDARD TONES								
Freq. (Hz)	Byte 1 (Hex)	Byte 2 (Hex)	Freq. (Hz)	Byte 1 (Hex)	Byte 2 (Hex)	Freq. (Hz)	Byte 1 (Hex)	Byte 2 (Hex)
<b>62.5</b>	0F	A0	<b>183.5</b>	05	52	<b>199.5</b>	04	E5
<b>64.7</b>	0F	18	<b>189.9</b>	05	24	<b>206.5</b>	04	BB
<b>159.8</b>	06	1C	<b>196.6</b>	04	F8	<b>229.1</b>	04	43

### 1.6.5 Rx Tone Table

The following table lists the commonly used CTCSS tones together with the values for programming the CTCSS RX PROGRAM register \$84.

N.B. The values for byte 1 and 2 below apply to tone address 0 only. These values will vary depending on the location they are programmed into.

STANDARD TONES								
Freq. (Hz)	Byte 1 (Hex)	Byte 2 (Hex)	Freq. (Hz)	Byte 1 (Hex)	Byte 2 (Hex)	Freq. (Hz)	Byte 1 (Hex)	Byte 2 (Hex)
<b>67.0</b>	03	DC	<b>103.5</b>	06	0B	<b>162.2</b>	09	86
<b>69.3</b>	04	0D	<b>107.2</b>	06	48	<b>167.9</b>	09	CA
<b>71.9</b>	04	42	<b>110.9</b>	06	86	<b>173.8</b>	0A	43
<b>74.4</b>	04	52	<b>114.8</b>	06	C4	<b>179.9</b>	0A	88
<b>77.0</b>	04	87	<b>118.8</b>	07	03	<b>186.2</b>	0B	02
<b>79.7</b>	04	98	<b>123.0</b>	07	43	<b>192.8</b>	0B	48
<b>82.5</b>	04	CF	<b>127.3</b>	07	83	<b>203.5</b>	0C	03
<b>85.4</b>	05	06	<b>131.8</b>	07	C4	<b>210.7</b>	0C	4A
<b>88.5</b>	05	18	<b>136.5</b>	08	06	<b>218.1</b>	0C	C7
<b>91.5</b>	05	50	<b>141.3</b>	08	48	<b>225.7</b>	0D	45
<b>94.8</b>	05	8B	<b>146.2</b>	08	8A	<b>233.6</b>	0D	C4
<b>97.4</b>	05	C2	<b>151.4</b>	08	CD	<b>241.8</b>	0E	43
<b>100.0</b>	05	CF	<b>156.7</b>	09	42	<b>250.3</b>	0E	C3

NON-STANDARD TONES								
Freq. (Hz)	Byte 1 (Hex)	Byte 2 (Hex)	Freq. (Hz)	Byte 1 (Hex)	Byte 2 (Hex)	Freq. (Hz)	Byte 1 (Hex)	Byte 2 (Hex)
<b>62.5</b>	03	9C	<b>183.5</b>	0A	C6	<b>199.5</b>	0B	C3
<b>64.7</b>	03	CB	<b>189.9</b>	0B	41	<b>206.5</b>	0C	0A
<b>159.8</b>	09	4C	<b>196.6</b>	0B	87	<b>229.1</b>	0D	83



## 1.7 Performance Specification

### 1.7.1 Electrical Performance

#### 1.7.1.1 Absolute Maximum Ratings

Exceeding these maximum ratings can result in damage to the device.

	Min.	Max.	Units
Supply ( $V_{DD} - V_{SS}$ )	-0.3	7.0	V
Voltage on any pin to $V_{SS}$	-0.3	$V_{DD} + 0.3$	V
Current into or out of $V_{DD}$ and $V_{SS}$ pins	-30	+30	mA
Current into or out of any other pin	-20	+20	mA

<b>E3 Package</b>	Min.	Max.	Units
Total Allowable Power Dissipation at $T_{amb} = 25^{\circ}\text{C}$		300	mW
... Derating		5	mW/ $^{\circ}\text{C}$
Storage Temperature	-55	+125	$^{\circ}\text{C}$
Operating Temperature	-40	+85	$^{\circ}\text{C}$

<b>P4 Package</b>	Min.	Max.	Units
Total Allowable Power Dissipation at $T_{amb} = 25^{\circ}\text{C}$		800	mW
... Derating		13	mW/ $^{\circ}\text{C}$
Storage Temperature	-55	+125	$^{\circ}\text{C}$
Operating Temperature	-40	+85	$^{\circ}\text{C}$

#### 1.7.1.2 Operating Limits

Correct operation of the device outside these limits is not implied.

	Notes	Min.	Max.	Units
Supply ( $V_{DD} - V_{SS}$ )		3.0	5.5	V
Operating Temperature		-40	+85	$^{\circ}\text{C}$
Xtal Frequency		3.9996	4.0004	MHz

**1.7.1.3 Operating Characteristics**

For the following conditions unless otherwise specified:

Xtal Frequency = 4.0MHz

Audio Level 0dB ref. = 308mVrms at 1kHz

 $V_{DD} = 3.0V$  to  $5.0V$ ,  $T_{amb} = -40^{\circ}C$  to  $+85^{\circ}C$ .

Composite Signal = 308mVrms at 1kHz + 75mVrms Noise + 31mVrms Sub-Audio Signal

Noise Bandwidth = 5kHz Band Limited Gaussian

	Notes	Min.	Typ.	Max.	Units	
<b>DC Parameters</b>						
<b>At <math>V_{DD} = 3.0V</math></b>						
$I_{DD}$ (powersaved)	2	-	0.2	0.3	mA	
$I_{DD}$ (Encoder or Decoder only Operating)	2	-	1.3	2.0	mA	
<b>At <math>V_{DD} = 5.0V</math></b>						
$I_{DD}$ (powersaved)	2	-	0.5	0.8	mA	
$I_{DD}$ (Encoder or Decoder only Operating)	2	-	3.2	4.8	mA	
<b>"C-BUS" Interface</b>						
Input Logic "1"		70%	-	-	$V_{DD}$	
Input Logic "0"		-	-	30%	$V_{DD}$	
Input Leakage Current (Logic "1" or "0")		-1.0	-	1.0	$\mu A$	
Input Capacitance		-	-	7.5	pF	
Output Logic "1" ( $I_{OH} = 120\mu A$ )		90%	-	-	$V_{DD}$	
Output Logic "0" ( $I_{OL} = 360\mu A$ )		-	-	10%	$V_{DD}$	
"Off" State Leakage Current ( $V_{out} = V_{DD}$ )	3	-	-	10.0	$\mu A$	
<b>AC Parameters</b>						
<b>CTCSS Decoder</b>						
Sensitivity	(Pure CTCSS Tone)	5	-	-26.0	-	dB
Response Time	(Composite Signal)		-	140	-	ms
De-Response Time	(Composite Signal)		-	145	-	ms
Frequency Range			60.0	-	251	Hz
<b>CTCSS Encoder</b>						
Frequency Range			60.0	-	251	Hz
Tone Frequency Resolution			-	-	0.3	%
Tone Amplitude Tolerance	1	-1.0	0	+1.0		dB
Total Harmonic Distortion		-	3.0	-		%
<b>Audio Band-Pass Filter</b>						
Passband	6	350	-	3000		Hz
Passband Gain (at 1.0kHz)	6	-	0	-		dB
Passband Ripple (w.r.t. gain at 1.0kHz)	6	-2.0	-	+0.5		dB
Stopband Attenuation	6	30.0	-	-		dB
Residual Hum and Noise		-	-50.0	-		dBp
Alias Frequency		-	62.5	-		kHz
<b>Audio Attenuator</b>						
Nominal Adjustment Range		0	-	48		dB
Attenuation Accuracy		-1.5	-	1.5		dB
Step Size		-	1.6	-		dB

		Notes	Min.	Typ.	Max.	Units
<b>Output Impedances</b>						
TX SUB-AUDIO OUT	(Enabled)		-	2.0	-	kΩ
TX/RX AUDIO OUT	(Enabled)		-	600	-	Ω
TX/RX AUDIO OUT	(Disabled)		-	500	-	kΩ
VOLUME OUT	(Enabled)	7	-	600	-	Ω
<b>Rx Amplifier</b>						
Open Loop Gain	(I/P = 1mV at 100Hz)		-	70.0	-	dB
Unity Gain Bandwidth			-	5.0	-	MHz
Input Impedance	(at 100Hz)		10.0	-	-	MΩ
Output Impedance	(Open Loop)		-	6.0	-	kΩ
<b>Xtal/Clock Input</b>						
Pulse Width ('High' or 'Low')		4	40.0	-	-	ns
Input Impedance (at 100Hz)			10.0	-	-	MΩ
Gain (I/P = 1mVrms at 100Hz)			20.0	-	-	dB

- Notes:**
1. At  $V_{DD} = 5.0V$  only. Signal levels or currents are proportional to  $V_{DD}$ .
  2. Not including any current drawn from the device pins by external circuitry.
  3. IRQN pin.
  4. Timing for an external input to the XTAL/CLOCK pin.
  5. With input gain components set as recommended in Figure 2.
  6. See filter response (Figure 5).
  7. Small signal impedance  $V_{DD} = 5.0V$  and  $T_{amb}=25^{\circ}C$ . A minimum load resistance of  $6k\Omega$  is suggested.

**1.7.1 Electrical Performance (continued)**

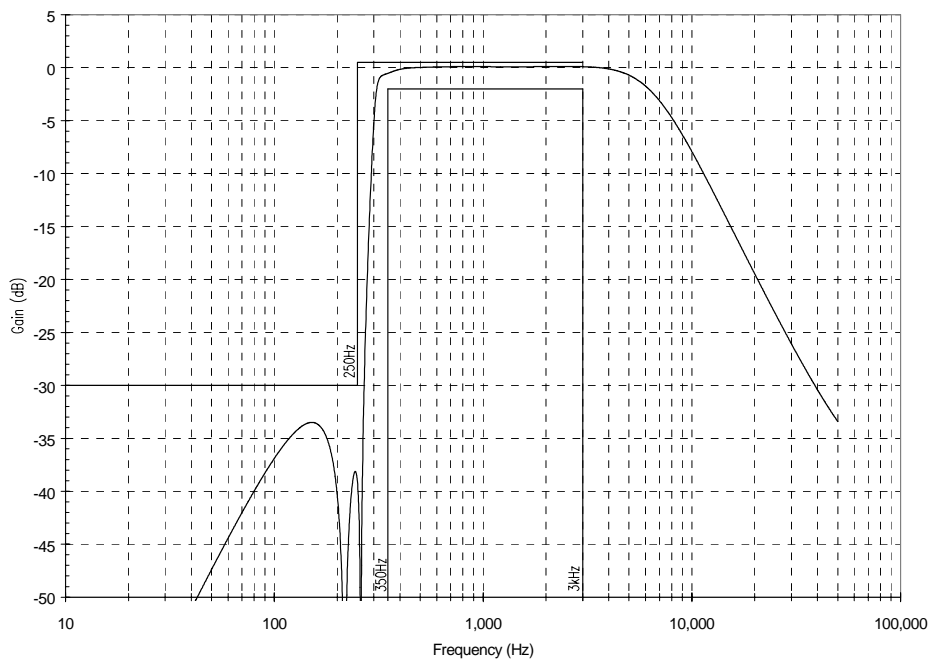

**Figure 5 Audio Band-Pass Filter Frequency Response**

1.7.1 Electrical Performance (continued)

Timing Diagrams

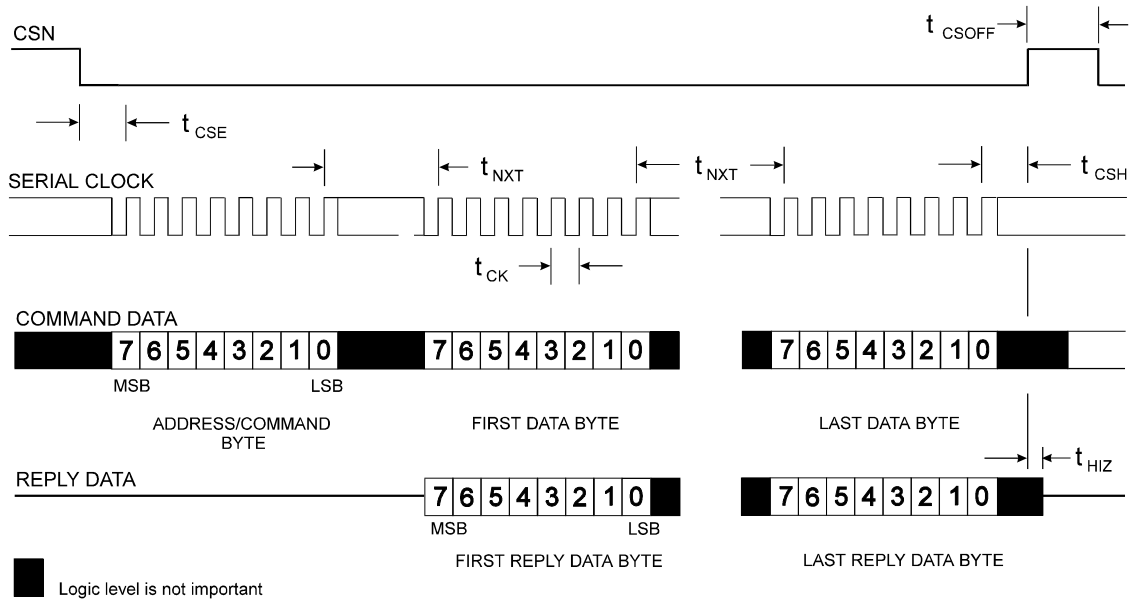

Figure 6 "C-BUS" Timing

For the following conditions unless otherwise specified:

Xtal Frequency = 4.0MHz,  $V_{DD}$  = 3.0V to 5.0V,  $T_{amb}$  = -40°C to +85°C.

Parameter	Notes	Min.	Typ.	Max.	Units
$t_{CSE}$	"CS-Enable to Clock-High"	2.0	-	-	$\mu$ s
$t_{CSH}$	Last "Clock-High to CS-High"	4.0	-	-	$\mu$ s
$t_{HIZ}$	"CS-High to Reply Output 3-state"	-	-	2.0	$\mu$ s
$t_{CSOFF}$	"CS-High" Time between transactions	2.0	-	-	$\mu$ s
$t_{NXT}$	"Inter-Byte" Time	4.0	-	-	$\mu$ s
$t_{CK}$	"Clock-Cycle" time	2.0	-	-	$\mu$ s

- Notes:**
- Depending on the command, 1 or 2 bytes of COMMAND DATA are transmitted to the peripheral MSB (Bit 7) first, LSB (Bit 0) last. REPLY DATA is read from the peripheral MSB (Bit 7) first, LSB (Bit 0) last.
  - Data is clocked into and out of the peripheral on the rising SERIAL CLOCK edge.
  - Loaded commands are acted upon at the end of each command.
  - To allow for differing  $\mu$ Controller serial interface formats "C-BUS" compatible ICs are able to work with either polarity SERIAL CLOCK pulses.

1.7.2 Packaging

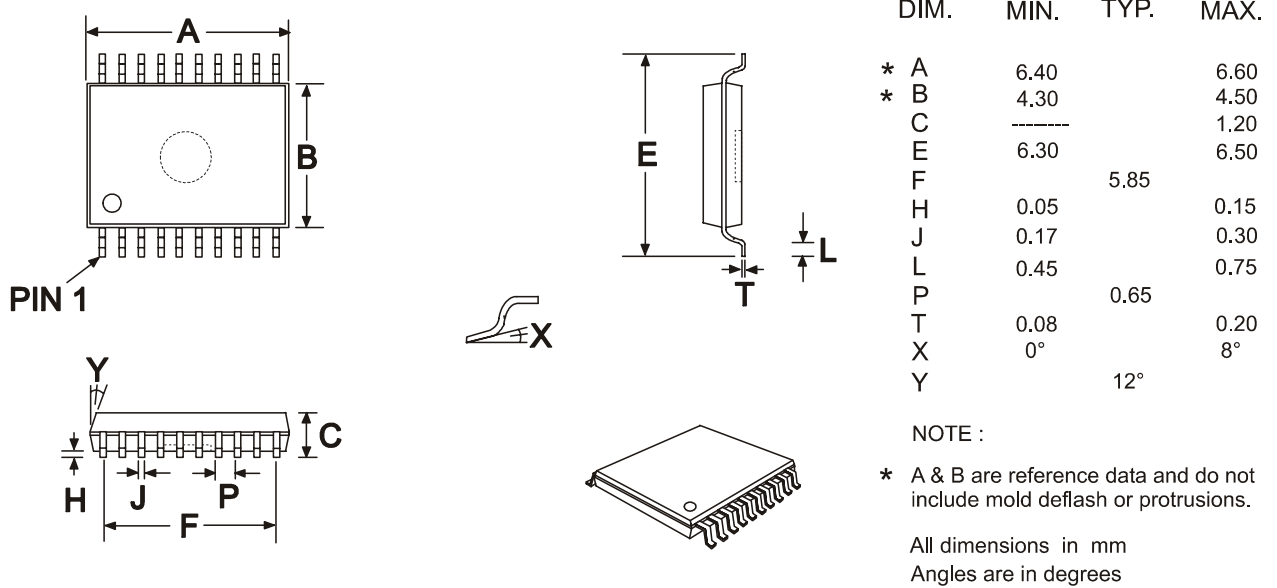

Figure 7 Mechanical Outline: Order as part no. CMX808AE3

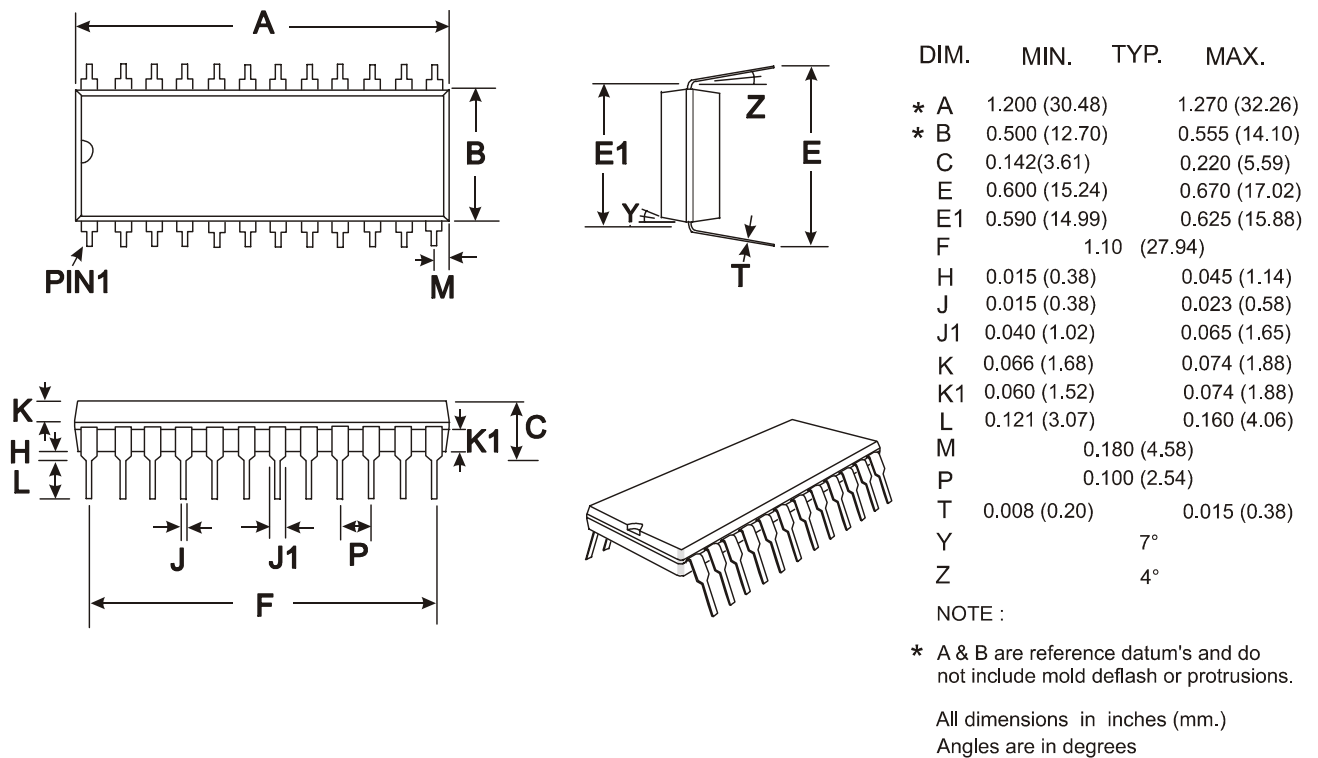

Figure 8 Mechanical Outline: Order as part no. CMX808AP4

Handling precautions: This product includes input protection, however, precautions should be taken to prevent device damage from electro-static discharge. CML does not assume any responsibility for the use of any circuitry described. No IPR or circuit patent licences are implied. CML reserves the right at any time without notice to change the said circuitry and this product specification. CML has a policy of testing every product shipped using calibrated test equipment to ensure compliance with this product specification. Specific testing of all circuit parameters is not necessarily performed.

**[www.cmlmicro.com](http://www.cmlmicro.com)**

**For FAQs see:** [www.cmlmicro.com/products/faqs/](http://www.cmlmicro.com/products/faqs/)

**For a full data sheet listing see:** [www.cmlmicro.com/products/datasheets/download.htm](http://www.cmlmicro.com/products/datasheets/download.htm)

**For detailed application notes:** [www.cmlmicro.com/products/applications/](http://www.cmlmicro.com/products/applications/)

 <b>CML Microcircuits (UK) Ltd</b> <small>COMMUNICATION SEMICONDUCTORS</small>	 <b>CML Microcircuits (USA) Inc.</b> <small>COMMUNICATION SEMICONDUCTORS</small>	 <b>CML Microcircuits (Singapore) Pte Ltd</b> <small>COMMUNICATION SEMICONDUCTORS</small>	
Oval Park, Langford, Maldon, Essex, CM9 6WG - England.  Tel: +44 (0)1621 875500 Fax: +44 (0)1621 875600  Sales: <a href="mailto:sales@cmlmicro.com">sales@cmlmicro.com</a>  Technical Support: <a href="mailto:techsupport@cmlmicro.com">techsupport@cmlmicro.com</a>	4800 Bethania Station Road, Winston-Salem, NC 27105 - USA.  Tel: +1 336 744 5050, 800 638 5577 Fax: +1 336 744 5054  Sales: <a href="mailto:us.sales@cmlmicro.com">us.sales@cmlmicro.com</a>  Technical Support: <a href="mailto:us.techsupport@cmlmicro.com">us.techsupport@cmlmicro.com</a>	No 2 Kallang Pudding Road, #09 to 05/06 Mactech Industrial Building, Singapore 349307  Tel: +65 6745 0426 Fax: +65 6745 2917  Sales: <a href="mailto:sg.sales@cmlmicro.com">sg.sales@cmlmicro.com</a>  Technical Support: <a href="mailto:sg.techsupport@cmlmicro.com">sg.techsupport@cmlmicro.com</a>	No. 218, Tian Mu Road West, Tower 1, Unit 1008, Shanghai Kerry Everbright City, Zhabei, Shanghai 200070, China.  Tel: +86 21 6317 4107 +86 21 6317 8916 Fax: +86 21 6317 0243  Sales: <a href="mailto:cn.sales@cmlmicro.com.cn">cn.sales@cmlmicro.com.cn</a>  Technical Support: <a href="mailto:sg.techsupport@cmlmicro.com">sg.techsupport@cmlmicro.com</a>

