

PLEASE CHECK WWW.MOLEX.COM FOR LATEST PART INFORMATION

Part Number: [0468190001](#)
Status: **Active**
Description: High Power Terminal 60A, 10Awg Crimp, Tin(Sn)

Documents:

[Drawing \(PDF\)](#) [RoHS Certificate of Compliance \(PDF\)](#)

General

Product Family	Crimp Terminals
Series	46819
Crimp Quality Equipment	Yes
Product Name	N/A

Physical

Gender	Female
Material - Metal	Copper
Material - Plating Mating	Nickel
Material - Plating Termination	Tin
Packaging Type	Reel
Termination Interface: Style	Crimp or Compression
Wire Insulation Diameter	4.70mm (.185") max.
Wire Size AWG	10
Wire Size mm ²	N/A

Material Info

Reference - Drawing Numbers

Sales Drawing	SD-46819-001
---------------	--------------

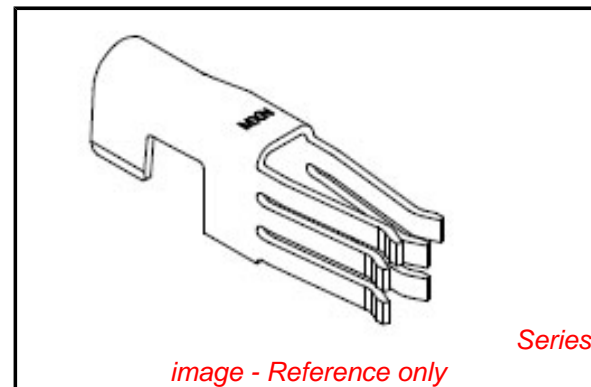

image - Reference only

EU RoHS

**ELV and RoHS
Compliant**
**REACH SVHC
Contains SVHC: No**
**Halogen-Free
Status**

China RoHS



**Need more information on product
environmental compliance?**

Email productcompliance@molex.com
 For a multiple part number RoHS Certificate of Compliance, [click here](#)

Please visit the [Contact Us](#) section for any non-product compliance questions.

Search Parts in this Series

[46819Series](#)

Mates With

[46817 Housing](#)

Application Tooling | FAQ

Tooling specifications and manuals are found by selecting the products below. Crimp Height Specifications are then contained in the Application Tooling Specification document.

Global

Description	Product #
Mini-Mac™ Applicator Air Feed for Power 60 Amp Crimp Terminals, 10 AWG	0638320800

PART NUMBER	CRIMP SIZE	NUMBER OF TERMINALS PER REEL	PLATING	DIM "A" WIDTH	DIM "B" HEIGHT
46819-0001	10	****	100μ INCHES OF MATTE TIN OVERALL OVER 50μ INCHES OF NICKEL OVERALL	5.37+0.25 -210+010	5.97+0.38 -235+015
46819-0002	8	****		7.12+0.25 -280+010	7.84+0.30 -309+012
46819-0003	6	****		7.62+0.25 -300+010	8.92+0.30 -350+012
46819-0011	10	****	100μ INCHES OF MATTE SELECT TIN OVER 50μ INCHES OF NICKEL OVERALL WITH 30μ INCHES OF SELECT GOLD	5.37+0.25 -210+010	5.97+0.38 -235+015
46819-0012	8	****		7.12+0.25 -280+010	7.84+0.30 -309+012
46819-0013	6	****		7.62+0.25 -300+010	8.92+0.30 -350+012

- NOTES:
1. MATERIAL: COPPER ALLOY .80/.032 THICK
 2. FINISH: PER MOLEX PLATING SPECIFICATION ES-88 - SEE CHART
 3. FOR CRIMP TOOLING CONTACT MOLEX OR VISIT THE MOLEX WEBSITE AT: WWW.MOLEX.COM
 4. SEE PRODUCT SPECIFICATION: PS-46819-001 FOR MORE INFORMATION
 5. FOR CRIMP SET UP INFORMATION SEE MOLEX APPLICATION SPECIFICATION DOCUMENT:
 - 6 AWG - ATS-638320600
 - 8 AWG - ATS-638320700
 - 10 AWG - ATS-638320800
 6. DESIGNED TO MATE WITH MOLEX P/N 46817-1****
 7. TERMINAL FOR USE WITH HOUSING 46818-0001
 8. TERMINAL FOR USE WITH TPA 46821-0001

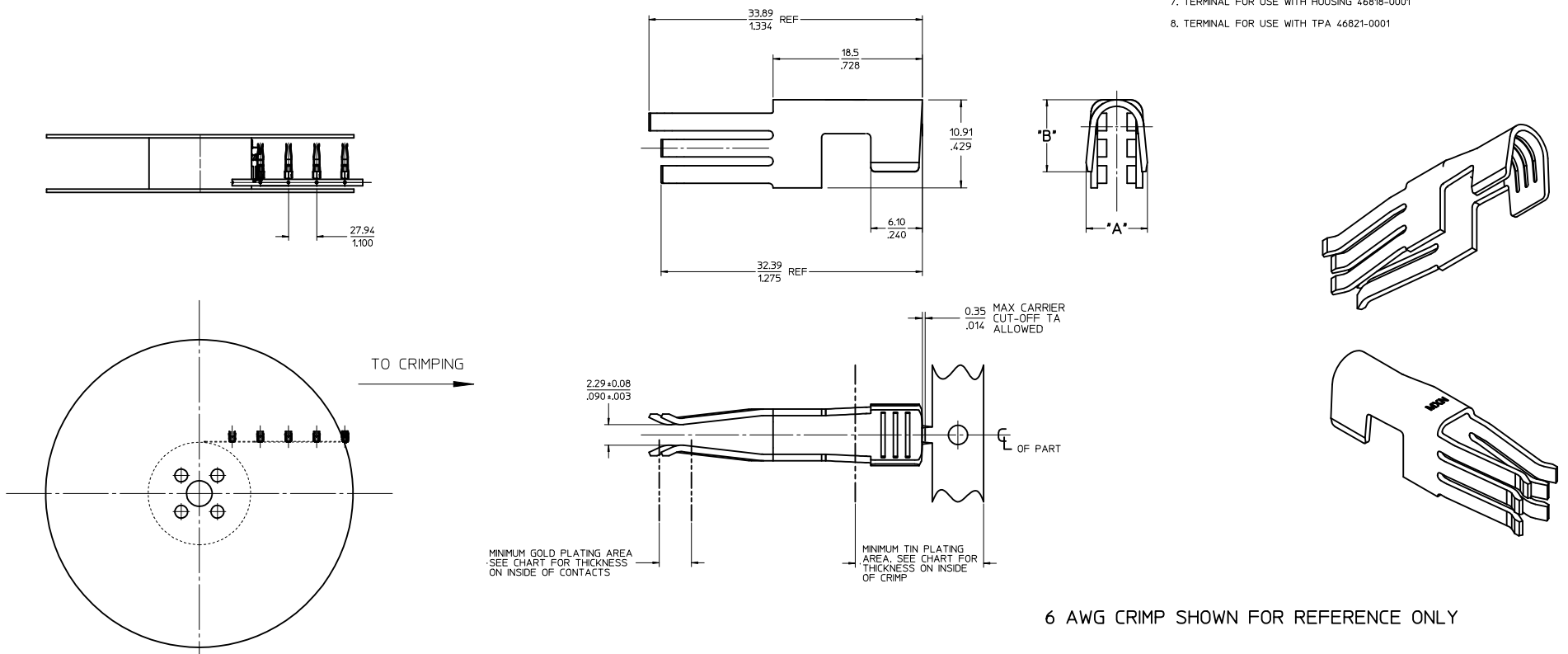

6 AWG CRIMP SHOWN FOR REFERENCE ONLY

REVISED NOTE IEC NO. UCF2010-1563 DRAWN: JUILLES 2010/01/11 CHKD: APATEL 2010/01/11 APPR: APATEL 2010/01/12 REV:	QUALITY SYMBOLS	GENERAL TOLERANCES (UNLESS SPECIFIED)	DIMENSION STYLE	SCALE	DESIGN UNITS	THIRD ANGLE PROJECTION
	▽=0	4 PLACES ± --- ± ---	MM/IN	4:1	METRIC	☉
	▽=0	3 PLACES ± --- ± .005				
	▽=0	2 PLACES ± 0.13 ± .010				
		1 PLACE ± 0.25 ± ---				
		ANGULAR ±1/2°				
		DRAFT WHERE APPLICABLE MUST REMAIN WITHIN DIMENSIONS				
			MATERIAL NO.	DATE	DATE	DATE
			SEE CHART	2009/03/09	2009/03/09	2009/03/10
			MOLEX INCORPORATED			
			DOCUMENT NO.			
			SD-46819-001			
						SHEET NO.
						1 OF 1