

# D Series Heatsinks

For SMT devices

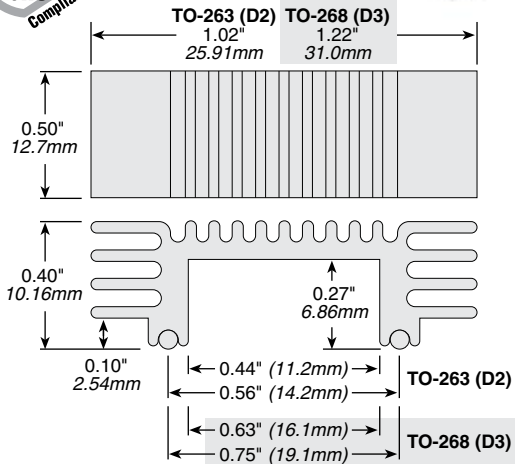

Note: order TO-263 for TO-252 devices

## LAND PATTERN

### TO-263 (D2)

use also for TO-252 (D)

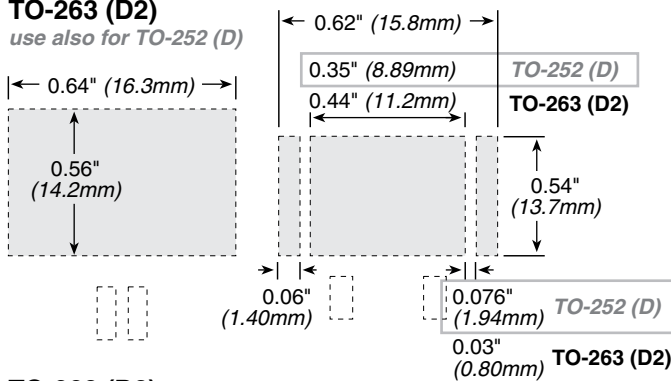

### TO-268 (D3)

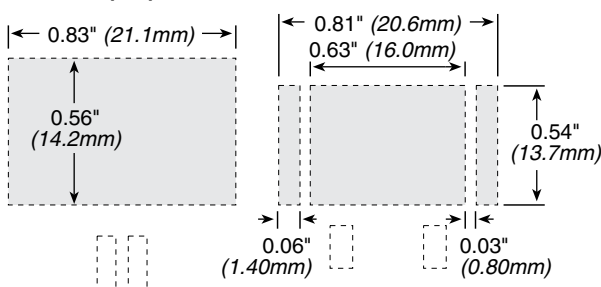

## TAPE AND REEL

- Pocket depth: 0.41" (10.50mm)
- Pocket pitch: 0.79" (20.00mm)
- Reel diameter: 13.00" (330.00mm)
- 250 pcs. per reel

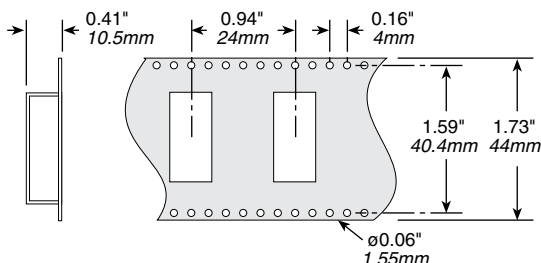

Ohmite D Series heatsinks provide an innovative solution for SMT compatible semiconductors and resistors. The unique design (Patent Pending) combines tin plated, solderable rods with an aluminum extruded heat sink body. These rods (or "rollers") are mated mechanically to the heatsink by forging to reduce the thermal resistance between the heatsink body and the solderable feet.

Specifically designed for use with the increasingly popular TO-252, TO-263 and TO-268 packages, the D Series affords the user superior thermal performance over the more common stamped aluminum heatsinks. By eliminating the staking joint typically used in stamped heatsinks, the resulting air gap and thermal "bottle-neck" is also eliminated, while surface area for cooling is maximized with the extruded fins of the D Series body.

## FEATURES

- Increased thermal performance up to 30% over bright copper heat sinks from improved radiation of the black finish
- Increased surface areas by 3 times therefore thermal performance up to 300% over the aluminum stamped heat sinks on markets
- Unique aluminum extrusion design reduces the heat sink cost versus similar designs utilizing copper
- Light weight aluminum construction allows faster pick and place assembly reducing the manufacturing cycle time
- Radius mounted "Rollers" are designed for maximizing heat transfer from the component and avoiding the thermal "bottle-neck" seen in stamped and staked heatsinks.
- Available in bulk packaging or tape & reel (250 units per reel)
- Weight:** D2 (TO-263): 3.8g  
D3 (TO-268): 4.1g
- RoHS Compliant

## HEAT DISSIPATION

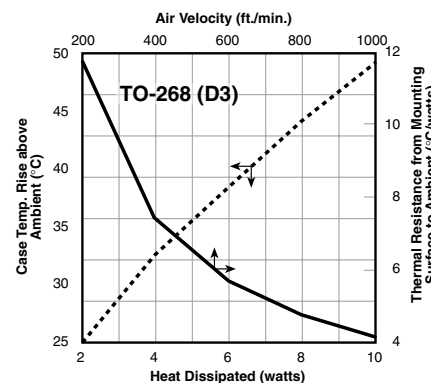
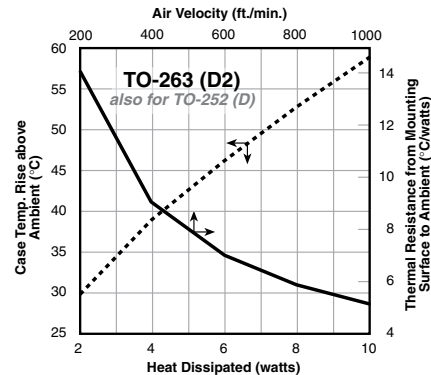

## STANDARD PART NUMBERS FOR D SERIES

Part Number	Description	Packaging
DV-T263-101E	for D2 pack, degreased finish	Bulk
DA-T263-101E	for D2 pack, black anodized finish	Bulk
DV-T263-101E-TR	for D2 pack, degreased finish	Reel
DA-T263-101E-TR	for D2 pack, black anodized finish	Reel
DV-T268-101E	for D3 pack, degreased finish	Bulk
DA-T268-101E	for D3 pack, black anodized finish	Bulk
DV-T268-101E-TR	for D3 pack, degreased finish	Reel
DA-T268-101E-TR	for D3 pack, black anodized finish	Reel

Note: order TO-263 for TO-252 devices