

WV Series Heatsinks

For TO-220 and TO-247 devices

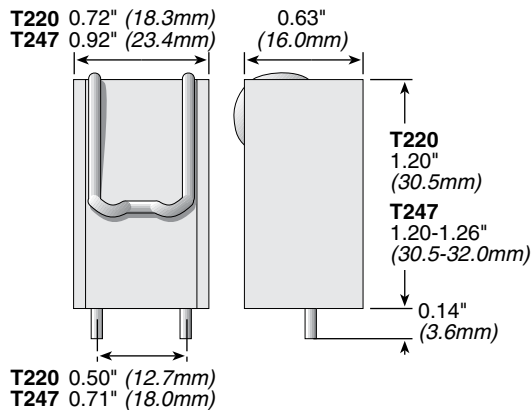

Heatsink Part Number	For Package Type	Ohmite Resistor Series	Surface Area (in ²)	Weight	Thermal Resistance*
WV-T220-101E	TO-220	TBH25, TCH35	6.5	0.35 oz/10g	R _{s-a} =10°C/W
WV-T247-101E	TO-247	TEH70	8.4	0.42 oz/12g	R _{s-a} =7°C/W

*Natural convection

Ohmite Manufacturing has launched a series of heatsink solutions for use with our popular TO-220 and TO-247 power resistors, or similarly packaged semiconductors. These self-aligning heatsinks feature solderable feet for through-hole placement, and an integrated clip which provides 13.2 (lbf) of force on the center of the resistor, enhancing thermal performance and reducing parts count and assembly time.

SPECIFICATIONS

- Heat Sink:** Aluminum alloy 6063-T5 or equivalent. Copper alloy C110 or equivalent
- Spring Clip:** Music wire, per ASTM A228
- Foot:** Cold-rolled steel, per ASTM A366, commercial quality or equivalent
- Insulator:** (optional) Sil-pad 900-S, K6 800-S, and K10, or equivalent
- Mounting:** thru-hole, vertical
- Suggested Sil Pad:** Sil-Pad 900S (Manufactured by Bergquist)
- Clip Force:** 13.2 lbf.

