

## TOY CAR REMOTE CONTROLLER WITH SEVEN FUNCTIONS

### DESCRIPTION

The TX-6B/RX-6B are a pair of CMOS LSIs designed for remote controlled car applications. They have seven control keys controlling the motions (i.e. forward, backward, rightward, leftward, two function keys and the turbo function) of the remote controlled car.

The TX-6B is housed in DIP-16 package, and the RX-6B is housed in DIP-18 package.

### FEATURES

- \* Wide operating voltage range  
TX-6B: ( $V_{DD}=2.2\sim 12.0V$ )  
RX-6B: ( $V_{DD}=3.0\sim 12.0V$ )
- \* Very Low stand-by current for TX-6B
- \* Auto-power-off function for TX-6B
- \* Few external components are needed
- \* Built-in 3.6V zener for RX-6B
- \* 7 functions remote controller controlling: forward, backward, right, left, turbo, and two function keys.

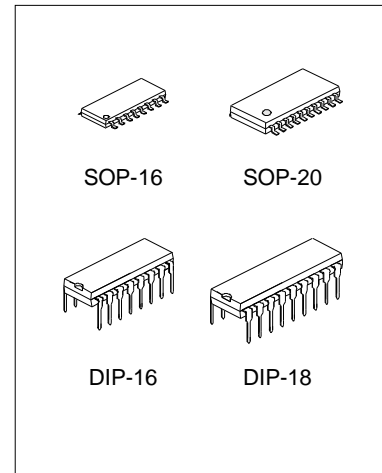

### ORDERING INFORMATION

Device	Package
TX-6B	DIP-16-300-2.54
RX-6B	DIP-18-300-2.54
TX-6BS	SOP-16-225-1.27
RX-6BS	SOP-20-300-1.27

### BLOCK DIAGRAM

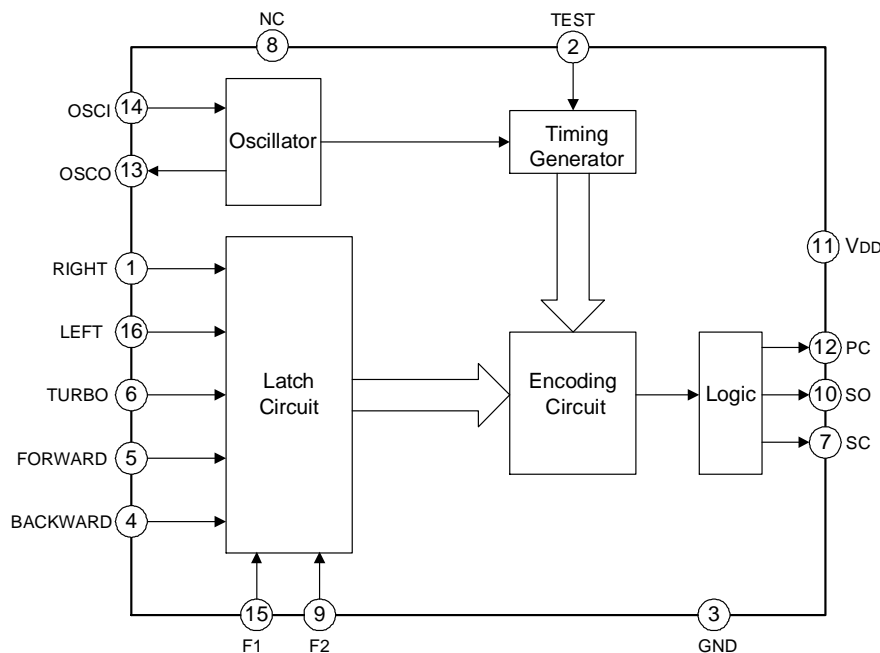

TX-6B/TX-6BS Block Diagram

**BLOCK DIAGRAM** (continued)

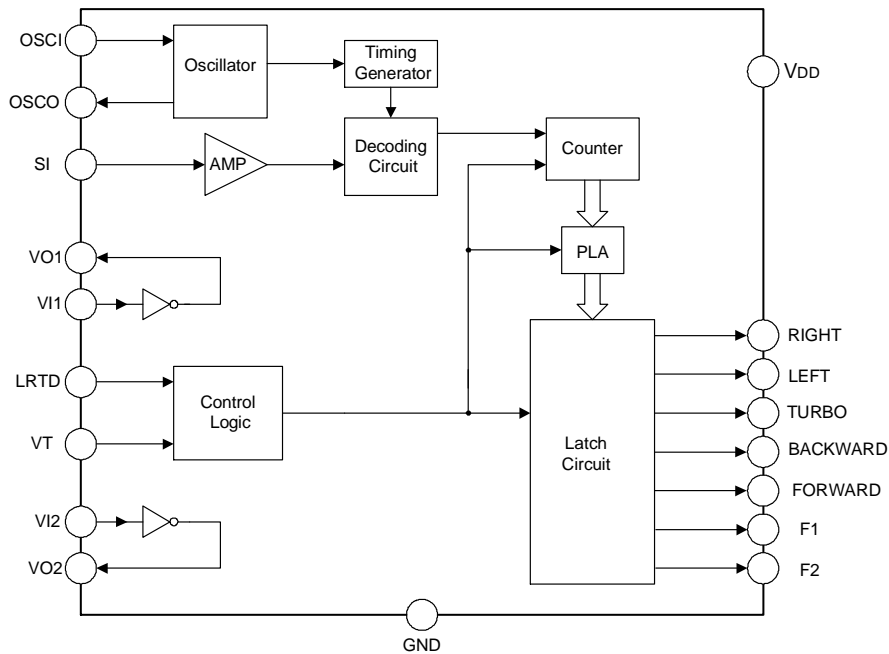

**RX-6B/RX-6BS Block Diagram**

**ABSOLUTE MAXIMUM RATINGS**

Characteristics	Symbol	Value	Unit
DC Supply Voltage	VDD	0.3 ~ 5.0	V
Input/Output Voltage	VIN, VOUT	GND-0.2V ~ VDD+0.2V	V
Operating Temperature	T <sub>opr</sub>	-10 ~ +60	°C
Storage Temperature	T <sub>stg</sub>	-25~+125	°C

**COMMENT**

Never allow a stress to exceed the values listed under "Absolute Maximum Ratings", otherwise the device would suffer from a permanent damage. Nor is a stress at the listed value be allowed to persist over a period, since an extended exposure to the absolute maximum rating condition may also affect the reliability of the device, if not causing a damage thereof.

**ELECTRICAL CHARACTERISTICS**

**TX-6B**

(VDD=9V, Fosc=128KHz, Tamb=25°C, unless otherwise specified.)

Characteristics	Symbol	Min.	Typ.	Max.	Unit
Operating Voltage	VDD	2.2	9.0	12.0	V
Operating Current	IDD	--	--	1.5	mA
Stand-By Current	ISTB	--	1.0	1000	μA
DC O/P Driving Current(RF)	I <sub>drive</sub>	--	10.0	--	mA
AC O/P Driving Current(IR)	I <sub>drive</sub>	--	6.0	--	mA
AC O/P Frequency	F <sub>audio</sub>	--	500	--	Hz

**RX-6B**

(VDD=9V, Fosc=128KHz, Tamb=25°C, unless otherwise specified.)

Characteristics	Symbol	Min.	Typ.	Max.	Unit
Operating Voltage	VDD	3.0	9.0	12.0	V
Operating Current	IDD	--	30.0	--	mA
O/P Driving Current	I <sub>drive</sub>	5.0	--	--	mA
O/P Driving Current(F1,F2)	I <sub>df</sub>	5.0	--	--	mA
Effect Decoding Frequency Variation	Ftolerance	-50%	--	50%	--

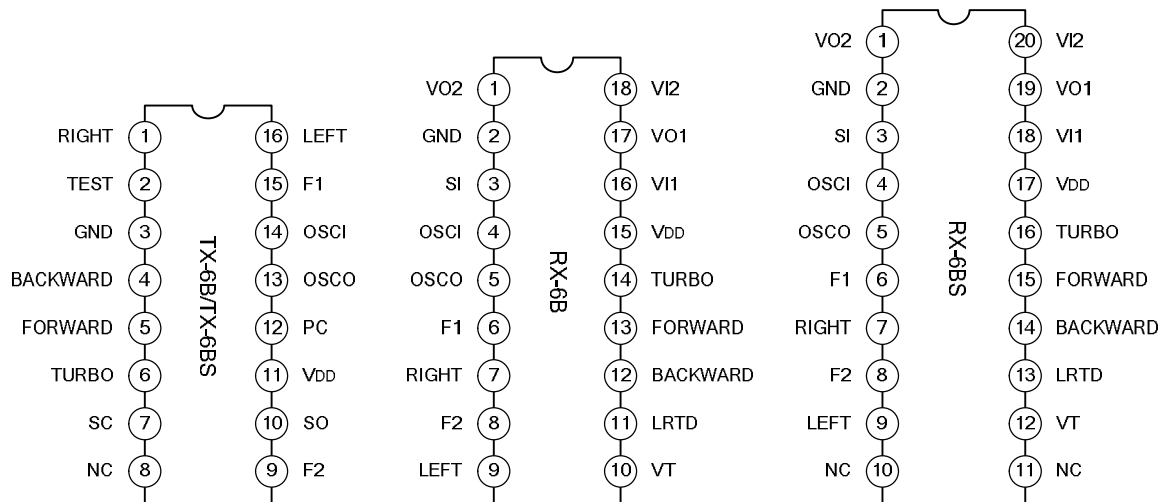
**PIN CONFIGURATION**

**PIN DESCRIPTION**
**TX-6B/TX-6BS**

Pin No.	Symbol	Description
1	RIGHT	The rightward function will be selected when this pin is connected to GND
2	TEST	This pin is used for testing mode
3	GND	Negative power supply
4	BACKWARD	The backward function will be selected when this pin is connected to GND
5	FORWARD	The forward function will be selected when this pin is connected to GND
6	TURBO	The turbo function will be selected, if this pin is connected to GND
7	SC	Output pin of the encoding signal with carrier frequency
8	NC	No connect
9	F2	F2 function select
10	SO	Output pin of the encoding signal without carrier frequency
11	VDD	Positive power supply
12	PC	Power control output pin
13	OSCO	Oscillator output pin
14	OSCI	Oscillator input pin
15	F1	F1 function select
16	LEFT	The leftward function will be selected when this pin is connected to GND

**RX-6B**

Pin No.	Symbol	Description
1	VO2	Inverter 2 output pin for signal amplify
2	GND	Negative power supply
3	SI	Input pin of the encoding signal
4	OSCI	Oscillator input pin
5	OSCO	Oscillator output pin
6	F1	F1 function output pin
7	RIGHT	Rightward output pin
8	F2	F2 function output pin
9	LEFT	Leftward output pin
10	VT	Auto Shut-OFF input pin. If VT voltage exceeds 1.4V, all outputs shut off automatically.
11	LRTD	Left/right turbo disable pin
12	BACKWARD	Backward output pin
13	FORWARD	Forward output pin
14	TURBO	TURBO output pin
15	VDD	Positive power supply
16	VI1	Inverter 1 input pin for signal amplify
17	VO1	Inverter 1 output pin for signal amplify
18	VI2	Inverter 2 input pin for signal amplify

**RX-6BS**

Pin No.	Symbol	Description
1	VO2	Inverter 2 output pin for signal amplify
2	GND	Negative power supply
3	SI	Input pin of the encoding signal
4	OSCI	Oscillator input pin
5	OSCO	Oscillator output pin
6	F1	F1 function output pin
7	RIGHT	Rightward output pin
8	F2	F2 function output pin
9	LEFT	Leftward output pin
10	NC	Not connect
11	NC	Not connect
12	VT	Auto Shut-OFF input pin. If VT voltage exceeds 1.4V, all outputs shut off automatically.
13	LRTD	Left/right turbo disable pin
14	BACKWARD	Backward output pin
15	FORWARD	Forward output pin
16	TURBO	TURBO output pin
17	VDD	Positive power supply
18	VI1	Inverter 1 input pin for signal amplify
19	VO1	Inverter 1 output pin for signal amplify
20	VI2	Inverter 2 input pin for signal amplify

## FUNCTION DESCRIPTION

The TX-6B/RX-6B are a pair of CMOS LSIs designed for remote controlled car applications. The TX-6B/RX-6B have seven control keys controlling the motions (i.e. forward, backward, rightward, leftward, two function keys and the turbo function) of the remote controlled car.

### 1. OVER-CURRENT PROTECTION

An Auto Shut-Off mechanism is built-in according to Toy Safety Requirement and effective during over-current situation in motor driver. The active high input applying to this Auto Shut-Off pin will turn off the motor. (VT pin, when unused, has to be connected to ground. The transfer point=1.4V)

### 2. DATA FORMAT

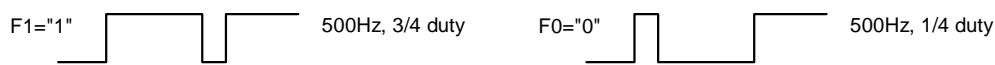

### 3. CODING METHOD

3.1 When a trigger pin is triggered, its data code will correspond to the data format of "F1", while the remaining pins will have the data format of "F0".

3.2. Data string: start code + data code + parity code + end code

Start code = F1 F1 F1 F1 F0

Data code =

F	B	T	R	L	F1	N	N	F2
---	---	---	---	---	----	---	---	----

F = Forward

B = Backward

T = Turbo

R = Right

L = Left

F1 = Function1

F2 = Function2

N = No used code

Parity code = for parity check

End code = for (latch data)

\* Data code can be any combination of F,B,T,R,L,F1,F2, except for F&B, R&L.

## OUTPUT TABLES

Function	Output Status						
	F	B	T	R	L	F1	F2
FORWARD	H						
LEFT+FORWARD	H				H		
RIGHT+FORWARD	H			H			
TURBO			H				
TURBO+FORWARD	H		H				
TURBO+LEFT+ FORWARD	H		H		H		
TURBO+RIGHT+FORWARD	H		H	H			
BACKWARD		H			H		
BACKWARD+RIGHT		H		H			
BACKWARD+LEFT		H					

(To be continued)

(Continued)

Function	Output Status						
	F	B	T	R	L	F1	F2
TURBO+BACKWARD		H	H		H		
TRUBO+BACKWARD+RIGHT		H	H	H			
TURBO+BACKWARD +LEFT		H	H				
LEFT					H		
RIGHT				H			
FUNCTION1						H	
FORWARD+FUNCTION1	H					H	
FORWARD+TURBO+FUNC1	H		H			H	
TURBO+FUNC1			H			H	
BACKWARD+FUNC1		H				H	
BACKWARD+TURBO+FUNC1		H	H			H	
LEFT+FORWARD+FUNC1	H				H	H	
RIGHT+FORWARD+FUNC1	H			H		H	
LEFT+ BACKWARD +FUNC1		H			H	H	
RIGHT+ BACKWARD +FUNC1		H		H		H	
LEFT+FUNCTION1					H	H	
RIGHT+FUNCTION1				H		H	

NOTE: (1) In the table, blank=F0. Rows from "FUNCTION1" to "RIGHT+FUNCTION1" (the last row) are similar for FUNCTION2. Thus, we can see from the table that we have more than 50 states of function combinations from 7 control keys.

(2) H = high level.

(3) LRTD pin functions as an option pin for LEFT/RIGHT turbo disable. Please refer to the following table.

"LRTD"	Key Selected	Output Function
HIGH (OPEN)	FORWARD+LEFT (RIGHT)+ TURBO	FORWARD+LEFT (RIGHT)+ TURBO
LOW	FORWARD+LEFT (RIGHT)+ TURBO	FORWARD+LEFT (RIGHT)

**TESTING CIRCUIT** ( $F_{osc}$  for RX-6B  $\approx$ 128KHz,  $F_{osc}$  for TX-6B  $\approx$ 128KHz)

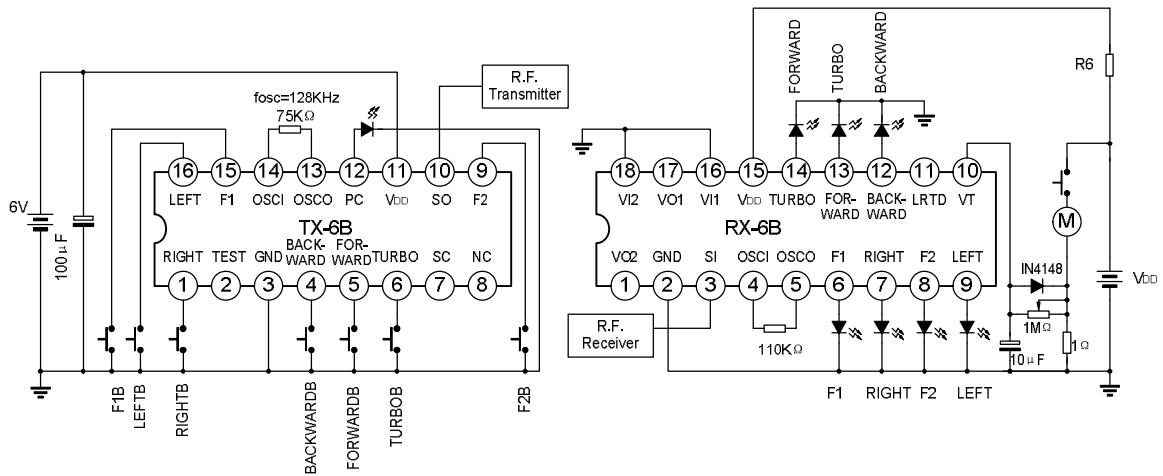

TX-6B output pin (SO) has an inverted phase with RX-6B input (SI). If TX-6B&RX-6B are connected without using a RF module, an inverter has to be inserted between these 2 pins, as shown in the right.

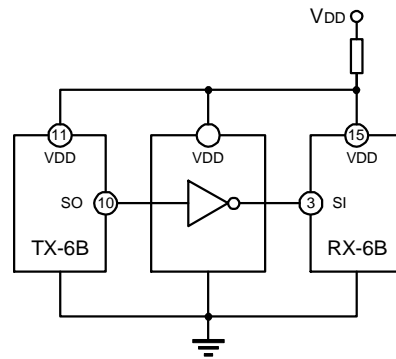

connect directly

*RX-6B R6, INDEX*

VDD	R6
12	270Ω
9	180Ω
6	68Ω





PACKAGE OUTLINE

DIP-16-300-2.54

UNIT: mm

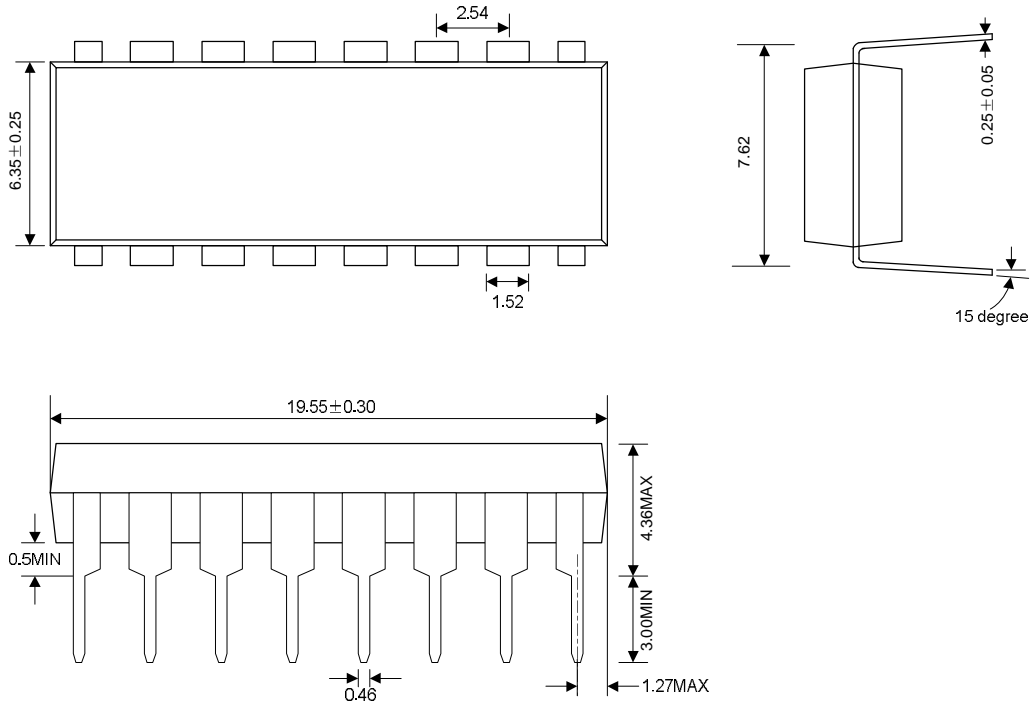

DIP-18-300-2.54

UNIT: mm

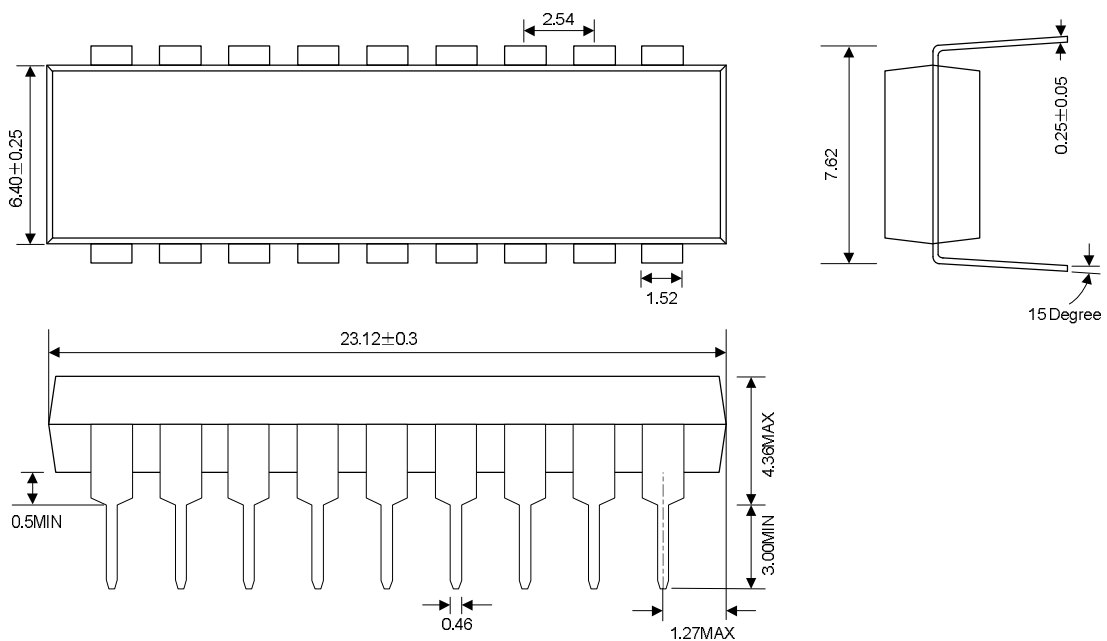

PACKAGE OUTLINE

SOP-16-225-1.27

UNIT: mm

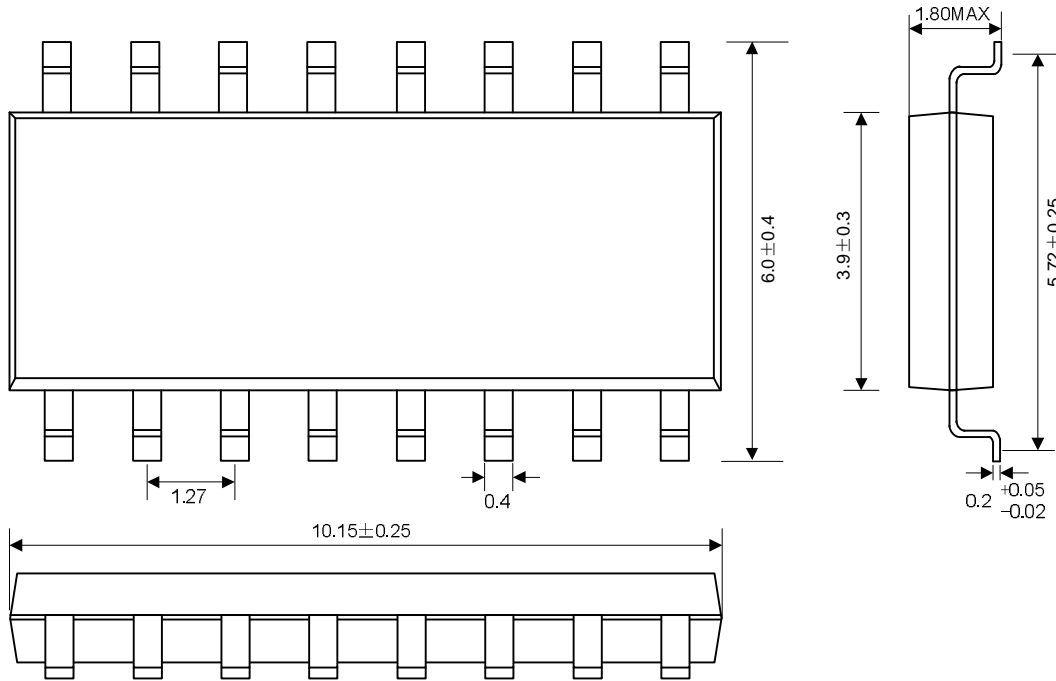

SOP-20-300-1.27

UNIT: mm

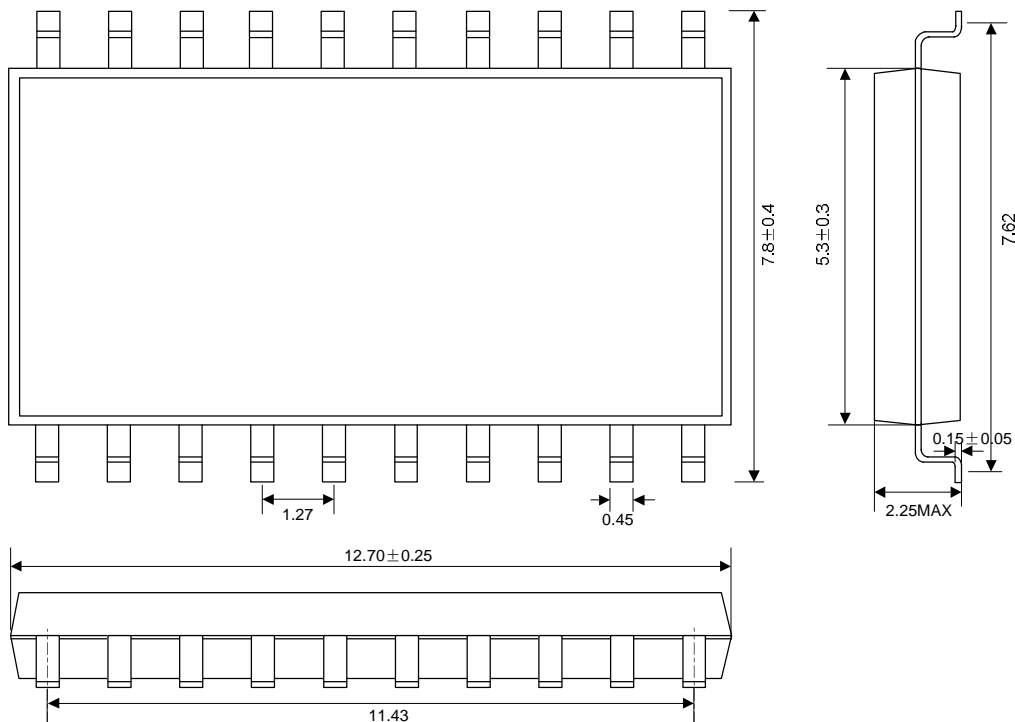



#### **HANDLING MOS DEVICES:**

Electrostatic charges can exist in many things. All of our MOS devices are internally protected against electrostatic discharge but they can be damaged if the following precautions are not taken:

- Persons at a work bench should be earthed via a wrist strap.
- Equipment cases should be earthed.
- All tools used during assembly, including soldering tools and solder baths, must be earthed.
- MOS devices should be packed for dispatch in antistatic/conductive containers.