

# Dielectric Patch Antenna

## Token Dielectric Antenna (DA) Technology Makes The List

### ▶ Preview

Dielectric antenna is fed using coaxial ceramic media. By a coaxial extension of the inner conductor to form an oscillator, used to excitation of electromagnetic waves, the sleeve of the role of the media, except clamping bar, the more important is the reflection of electromagnetic waves, thus ensuring the incentives from the coaxial line inner conductor of electromagnetic waves to the free end of dielectric rod transmission.

Token use of low-loss dielectric antennas, high-frequency dielectric material, strict process control, apply to the Global Positioning System (GPS), radio broadcast system of small antenna elements.

Token electronics manufacturing dielectric patch antenna with rectangular microstrip antenna design and offset one point feeding method for Global Positioning System GPS, media filters, multi-layer filters, cavity filters, band-pass filter, military filters, high-frequency filters and so on, in line with RoHS standards.

DA series of microwave antenna, which provides clients a custom design and deliver smaller tolerances. Dielectric antenna application specific design, but also for the frequency requirements, including different inductance values and Q specifications adjusted.

Token will also produce devices outside these specifications to meet specific customer requirements, please contact our sales for more information.

### ▶ Features

- Small patch dimensions.
- Using high quality factor.
- Stabilized temperature coefficient.
- Provide highly stabilized performance.

### ▶ Applications

- Global Positioning Systems (GPS)
- GPS Hold, Car Navigation System, GPS PDA.
- W-LAN.



## Typical Specifications

Part Number	Size (mm)	Center Frequency (MHz)	Band width (MHz)	Gain (dBi)	Ground Plane (mm)	Application
DA1575S25T4A	25*25*4	1575	≥10	4.5	35*35	GPS
DA1575S25T4B	25*25*4	1575	≥10	4.5	70*70	
DA1575S25T2B	25*25*2	1575	≥10	4.5	70*70	
DA1580S25T4A	25*25*4	1580	≥15	4.5	35*35	
DA1580S25T4B	25*25*4	1580	≥15	4.5	70*70	
DA1580S25T2B	25*25*2	1580	≥15	4.5	70*70	
DA1580S18T4	18*18*4	1580	≥10	3.0	50*50	
DA1580S18T2	18*18*2	1580	≥10	3.0	50*50	
DA1580S13T4	13*13*4	1580	≥5	0.0	50*50	
DA2450S13T4	13*13*4	2450	≥5	0.0	50*50	
DA2450S13T2	13*13*2	2450	≥5	0.0	50*50	
DA1575S36T4	36*36*4	1575	≥30	5.0	80*80	
DA2450D16	Φ16	2450	45	2.1	50*70	W-LAN
DA1616S25(Tx)	25*25*4	1616	≥10	4.0	70*70	Beidou Satellite Position System
DA2492S25(Rx)	25*25*4	2492	≥10	4.0	70*70	

Note: Fo available on request. Other parameters available on request.

## Dimensions (Unit: mm)

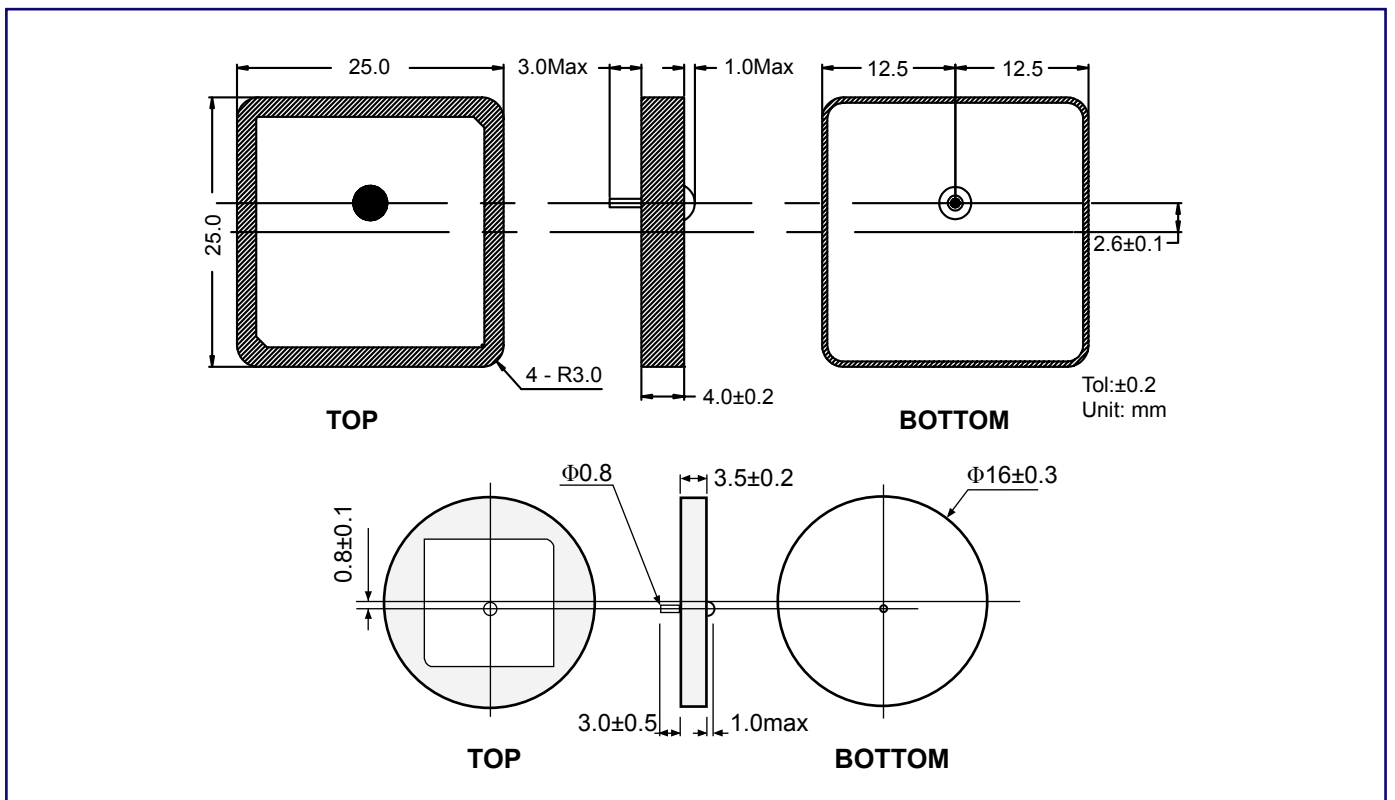

## Typical Characteristic

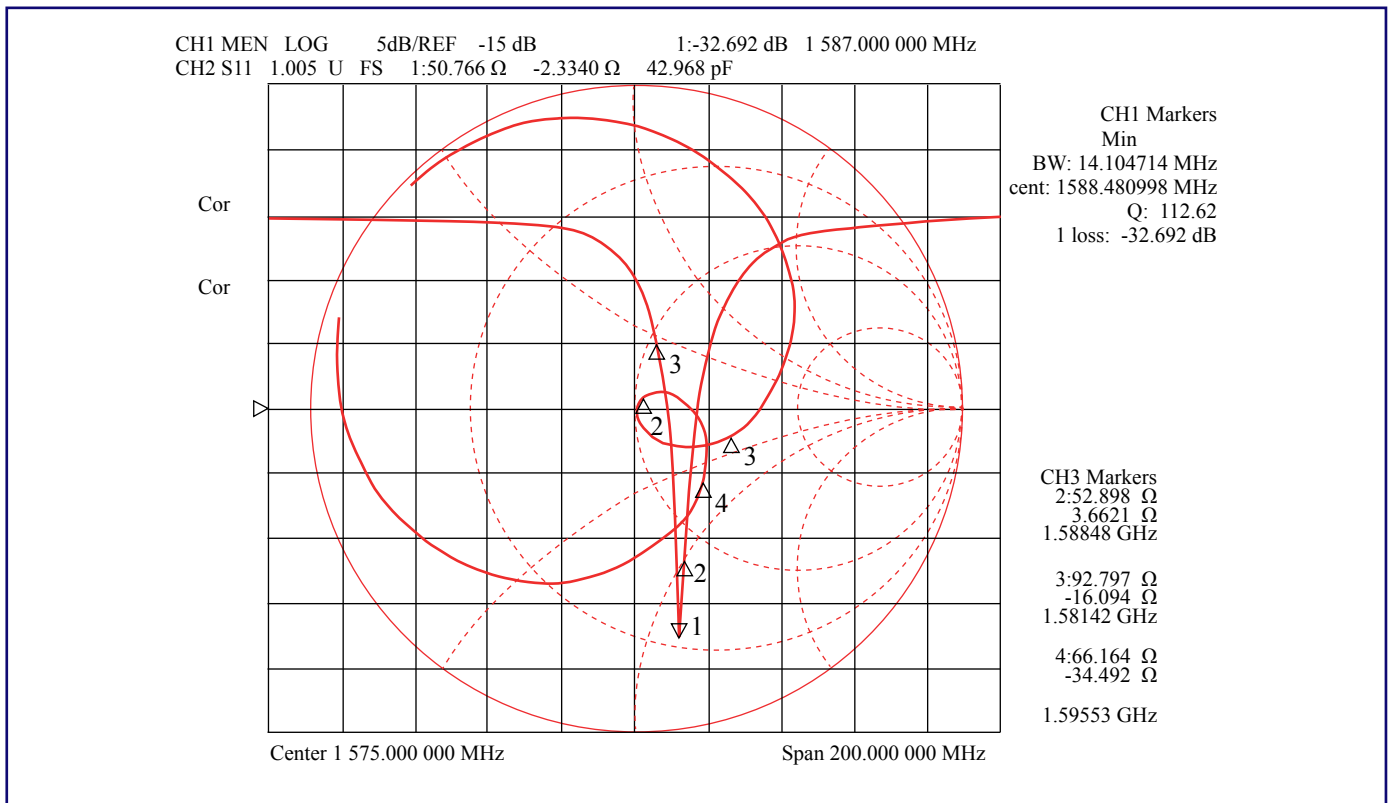

## How to Order

- DA  
①
- 1580  
②
- S  
③
- 18  
④
- T2  
⑤

- ① Dielectric Patch Antenna
- ② Center Frequency
- ③ Structure
- ④ Dimensions
- ⑤ Thickness

*Back to 1st Page - Dielectric Patch Antenna - DA*