

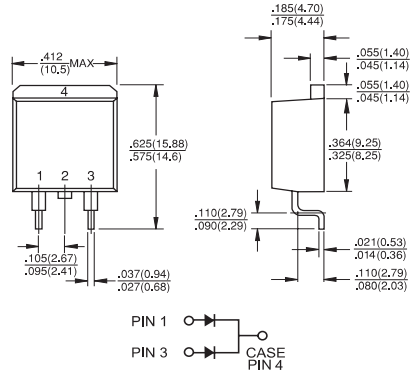

Features

- ✧ For surface mounted application
- ✧ Ideal for automated pick & place
- ✧ Low power loss, high efficiency
- ✧ High current capability, low VF
- ✧ High reliability
- ✧ Epitaxial construction
- ✧ Guard-ring for transient protection



Mechanical Data

- ✧ Cases: D²PAK molded plastic
- ✧ Epoxy: UL 94V-0 rate flame retardant
- ✧ Terminals: Pure tin plated, lead free. solderable per MIL-STD-202, Method 208 guaranteed
- ✧ Polarity: As marked
- ✧ High temperature soldering guaranteed: 260°C/10 seconds at terminals
- ✧ Weight: 1.70 grams

Dimensions in inches and (millimeters)

Maximum Ratings and Electrical Characteristics

Rating at 25 °C ambient temperature unless otherwise specified.

Single phase, half wave, 60 Hz, resistive or inductive load.

For capacitive load, derate current by 20%

Type Number	Symbol	SRS 2020	SRS 2030	SRS 2040	SRS 2050	SRS 2060	SRS 2090	SRS 20100	SRS 20150	Units
Maximum Recurrent Peak Reverse Voltage	V _{RRM}	20	30	40	50	60	90	100	150	V
Maximum RMS Voltage	V _{RMS}	14	21	28	35	42	63	70	105	V
Maximum DC Blocking Voltage	V _{DC}	20	30	40	50	60	90	100	150	V
Maximum Average Forward Rectified Current See Fig. 1	I _(AV)	20								A
Peak Forward Surge Current, 8.3 ms Single Half Sine-wave Superimposed on Rated Load (JEDEC method)	I _{FSM}	200								A
Maximum Instantaneous Forward Voltage @ 10A	V _F	0.55		0.70		0.92		1.02		V
Maximum D.C. Reverse Current @ Tc=25 °C at Rated DC Blocking Voltage @ Tc=100 °C	I _R	0.5				0.1				mA
		15		10		5.0			mA	
Typical Junction Capacitance (Note 2)	C _j	600		400		350			pF	
Typical Thermal Resistance (Note 1)	R _{θJC}	1.5								°C/W
Operating Junction Temperature Range	T _J	-65 to +125				-65 to +150				°C
Storage Temperature Range	T _{STG}	-65 to +150								°C

Notes: 1. Thermal Resistance from Junction to Case Per Leg
2. Measured at 1MHz and Applied Reverse Voltage of 4.0V D.C.

RATINGS AND CHARACTERISTIC CURVES (SRS2020 THRU SRS20150)

FIG.1- FORWARD CURRENT DERATING CURVE

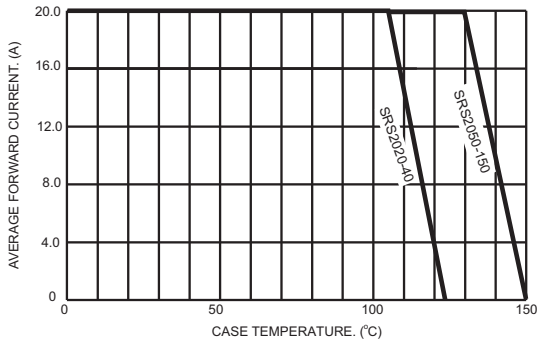

FIG.2- MAXIMUM NON-REPETITIVE PEAK FORWARD SURGE CURRENT PER LEG

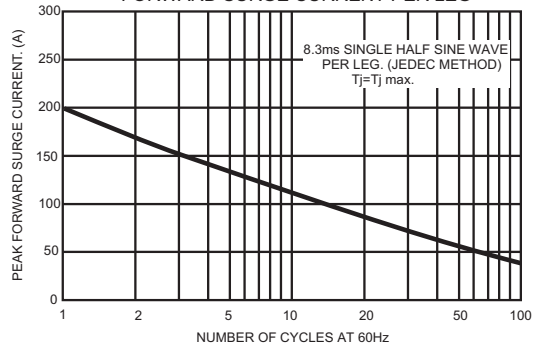

FIG.3- TYPICAL FORWARD CHARACTERISTICS PER LEG

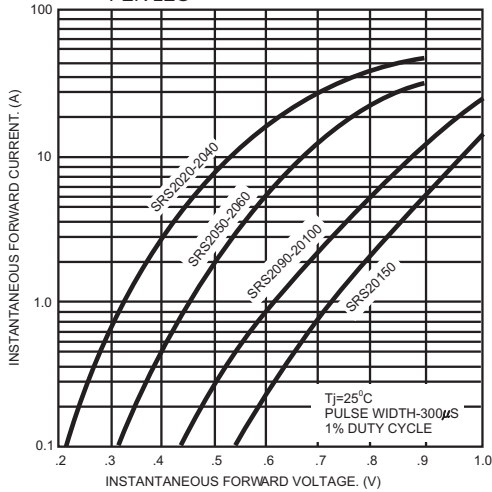

FIG.4- TYPICAL REVERSE CHARACTERISTICS PER LEG

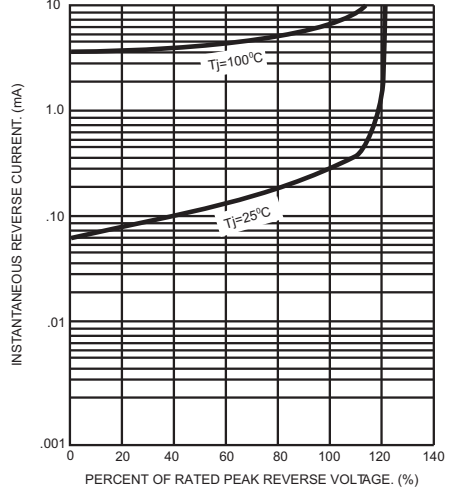

FIG.6- TYPICAL JUNCTION CAPACITANCE PER LEG

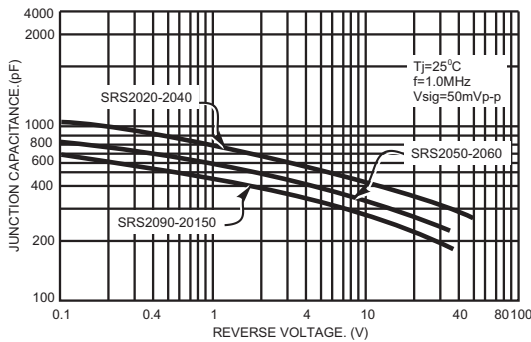

FIG.6- TYPICAL TRANSIENT THERMAL IMPEDANCE PER LEG

