



# SB520 SERIES

## SCHOTTKY BARRIER RECTIFIERS

**VOLTAGE** 20 to 60 Volts **CURRENT** 5 Amperes

**DO-201AD** Unit : inch(mm)

### FEATURES

- Plastic package has Underwriters Laboratory Flammability Classification 94V-O utilizing Flame Retardant Epoxy Molding Compound.
- Exceeds environmental standards of MIL-S-19500/228
- For use in low voltage, high frequency inverters, free wheeling, and polarity protection applications.
- In compliance with EU RoHS 2002/95/EC directives

### MECHANICAL DATA

- Case: DO-201AD Molded plastic
- Terminals: Axial leads, solderable per MIL-STD-750, Method 2026
- Polarity: Color band denotes cathode
- Mounting Position: Any
- Weight: 0.039 ounces, 1.122 grams

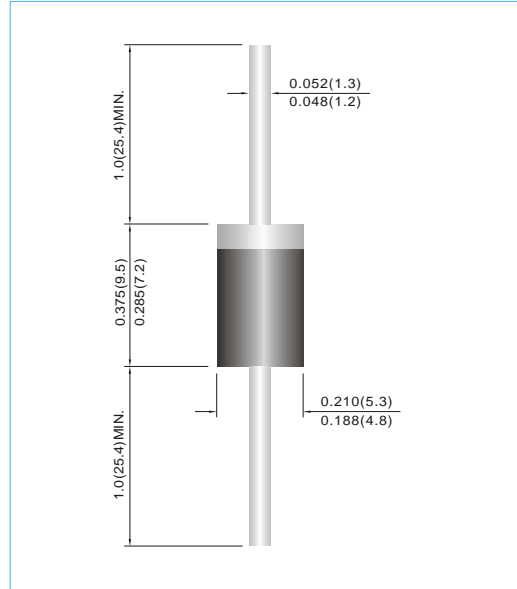

## MAXIMUM RATINGS AND ELECTRICAL CHARACTERISTICS

Ratings at 25°C ambient temperature unless otherwise specified. Single phase, half wave, 60 Hz, resistive or inductive load.

PARAMETER	SYMBOL	SB520	SB530	SB540	SB550	SB560	UNITS
Maximum Recurrent Peak Reverse Voltage	$V_{RRM}$	20	30	40	50	60	V
Maximum RMS Voltage	$V_{RMS}$	14	21	28	35	42	V
Maximum DC Blocking Voltage	$V_{DC}$	20	30	40	50	60	V
Maximum Average Forward Rectified Current (See Fig 1)	$I_{F(AV)}$	5					A
Peak Forward Surge Current : 8.3ms single half sine-wave superimposed on rated load (JEDEC method)	$I_{FSM}$	150					A
Maximum Forward Voltage at 5.0A (NOTES 3)	$V_F$	0.55			0.70		V
Maximum DC Reverse Current at Rated DC Blocking Voltage $T_J=25^{\circ}C$ $T_J=100^{\circ}C$	$I_R$	0.2 50			0.1 50		mA
Typical Thermal Resistance (NOTES 2) (NOTES 1) (NOTES 1)	$R_{\theta JA}$ $R_{\theta JC}$ $R_{\theta JL}$	50 12 15					$^{\circ}C / W$
Power Dissipation	$P_D$	5					W
Operating Junction Temperature Range	$T_J$	-55 to +125			-55 to +150		$^{\circ}C$
Storage Temperature Range	$T_{STG}$	-55 to +150					$^{\circ}C$

NOTES:

- Measured at ambient temperature at a distance of 9.5mm from the case
- Minimum Pad Area
- Pulse test : 300µs pulse width, 1% duty cycle



# SB520 SERIES

## RATING AND CHARACTERISTIC CURVES

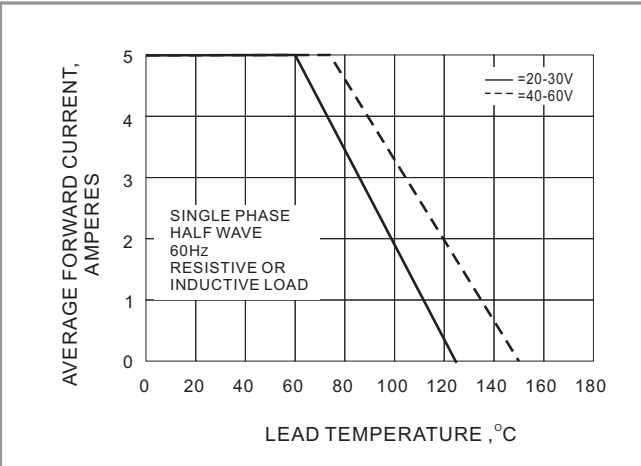

Fig. 1- FORWARD CURRENT DERATING CURVE

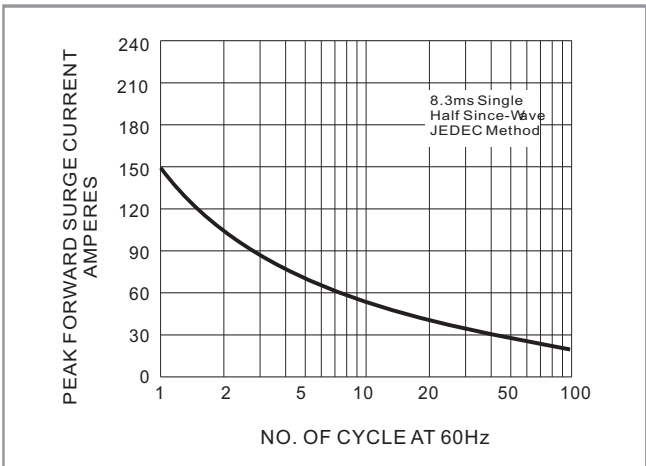

Fig. 2- MAXIMUM NON - REPETITIVE SURGE CURRENT

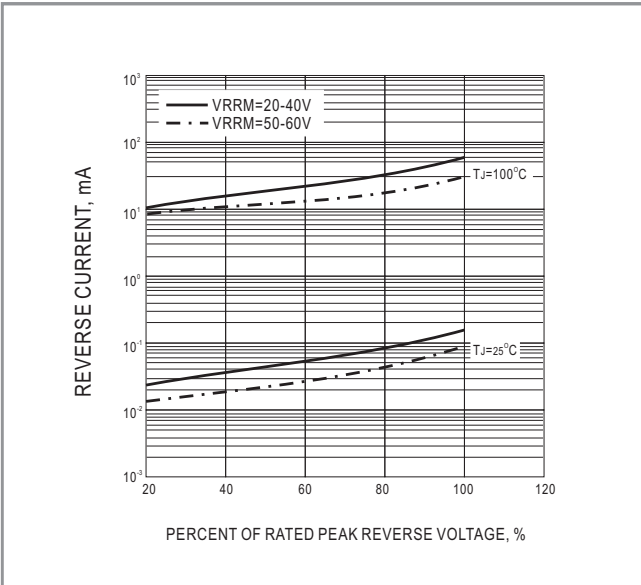

Fig. 3- TYPICAL REVERSE CHARACTERISTIC

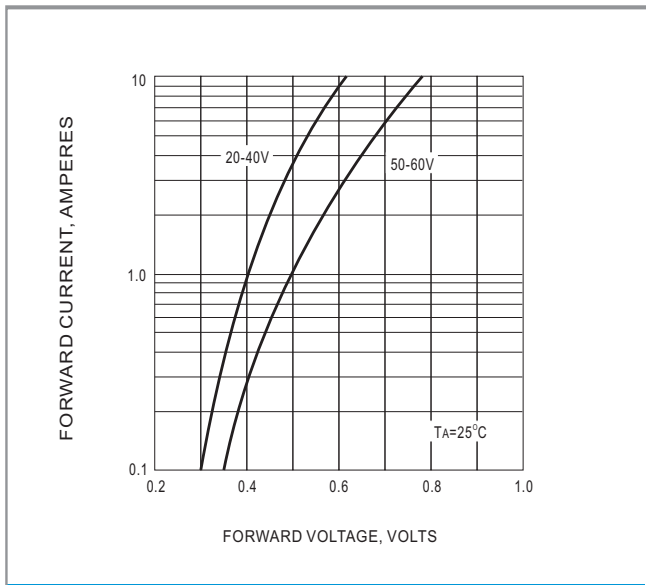

Fig. 4- TYPICAL INSTANTANEOUS FORWARD CHARACTERISTIC