

Data Sheet

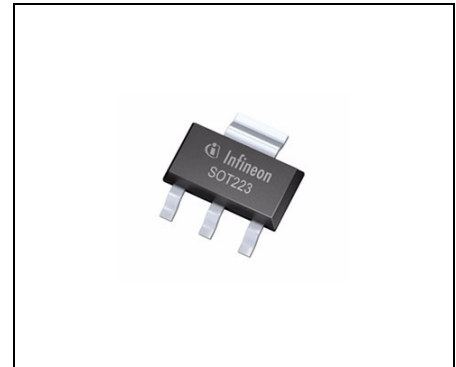

Features

- Output voltage 3.3 V or adjustable
- 1.0 A output current
- Low drop voltage < 1.2 V @ 800 mA
- Short circuit protected
- Overtemperature protected
- Operating range up to 15 V
- Industrial type
- Green Product (RoHS compliant)



For automotive and transportation applications, please refer to the Infineon TLE and TLF voltage regulator series.

Functional Description

The IFX 1117 is a monolithic integrated fixed NPN type voltage regulator that can supply loads up to 1.0 A. The device is housed in the small surface mounted SOT223 package. The IC is equipped with additional protection against overload, short circuit and overtemperature.

The IFX 1117 GSV33 supplies a regulated output voltage of 3.3 V ($\pm 2\%$). The IFX 1117 GSV supplies an output voltage with $\pm 2\%$ precision adjustable via an external voltage divider. The input voltage for the IFX 1117 GSV33 ranges from 4.5 V ($= V_Q + V_{DR}$) to 15 V for a load current of 800 mA, for the maximum load current of 1.0 A a minimum input voltage of 4.7 V is required. The drop voltage V_{DR} ranges from 1.1 V to 1.4 V depending on the load current level.

The device operates in the temperature range of $T_j = 0$ to 125 °C.

Type	Package	Marking
IFX 1117 GSV33	PG-SOT223-4	111733
IFX 1117 GSV	PG-SOT223-4	1117V

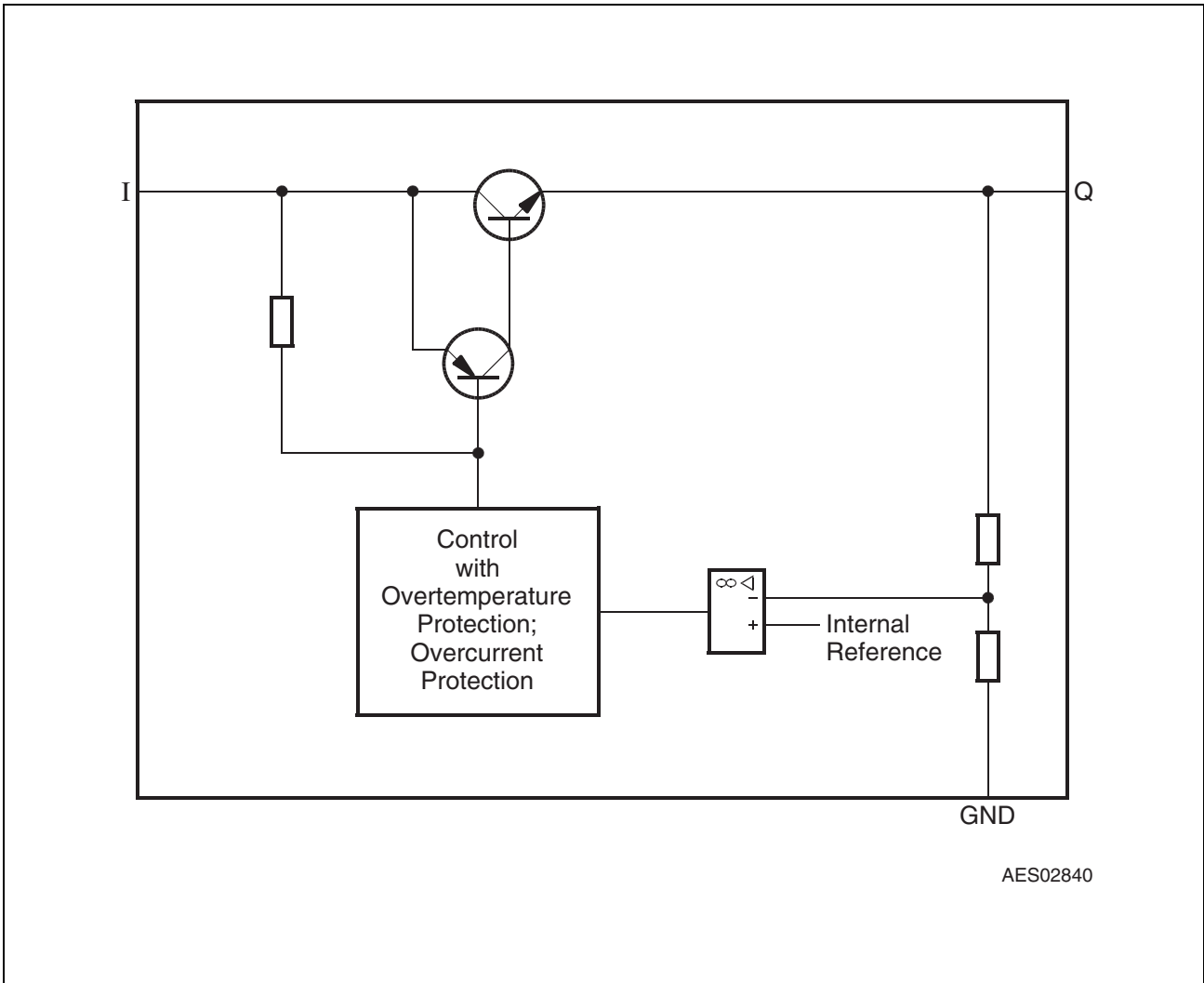

Figure 1 Block Diagram for Fixed Output Voltage IFX 1117 GSV33

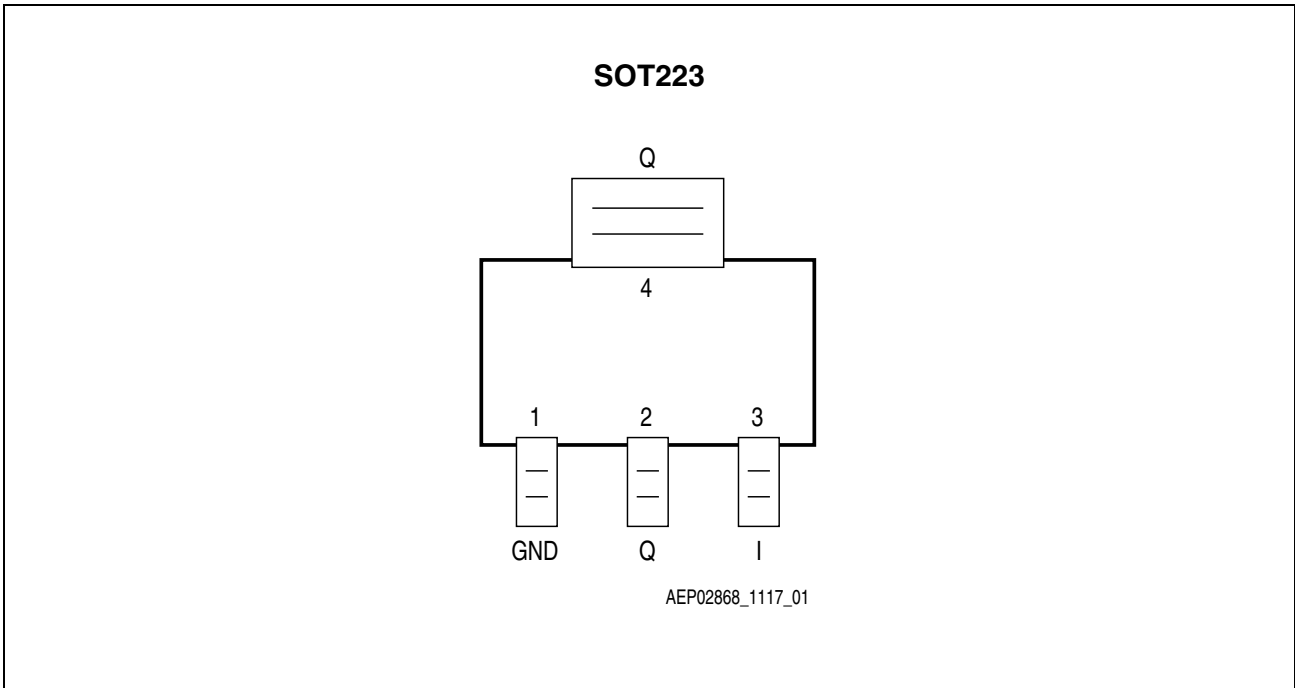

Figure 2 Pin Configuration IFX 1117 GSV33 (top view)

Table 1 Pin Definitions and Functions IFX 1117 GSV33

Pin No.	Symbol	Function
1	GND	Ground
2	Q	Output; Connect output pin to GND via a capacitor $C_Q \geq 10 \mu\text{F}$ with $\text{ESR} \leq 20 \Omega$ (see also graph “Region of Stability”)
3	I	Input
4 (TAB)	Q	Output; Connect to pin 2 and heatsink area on PCB

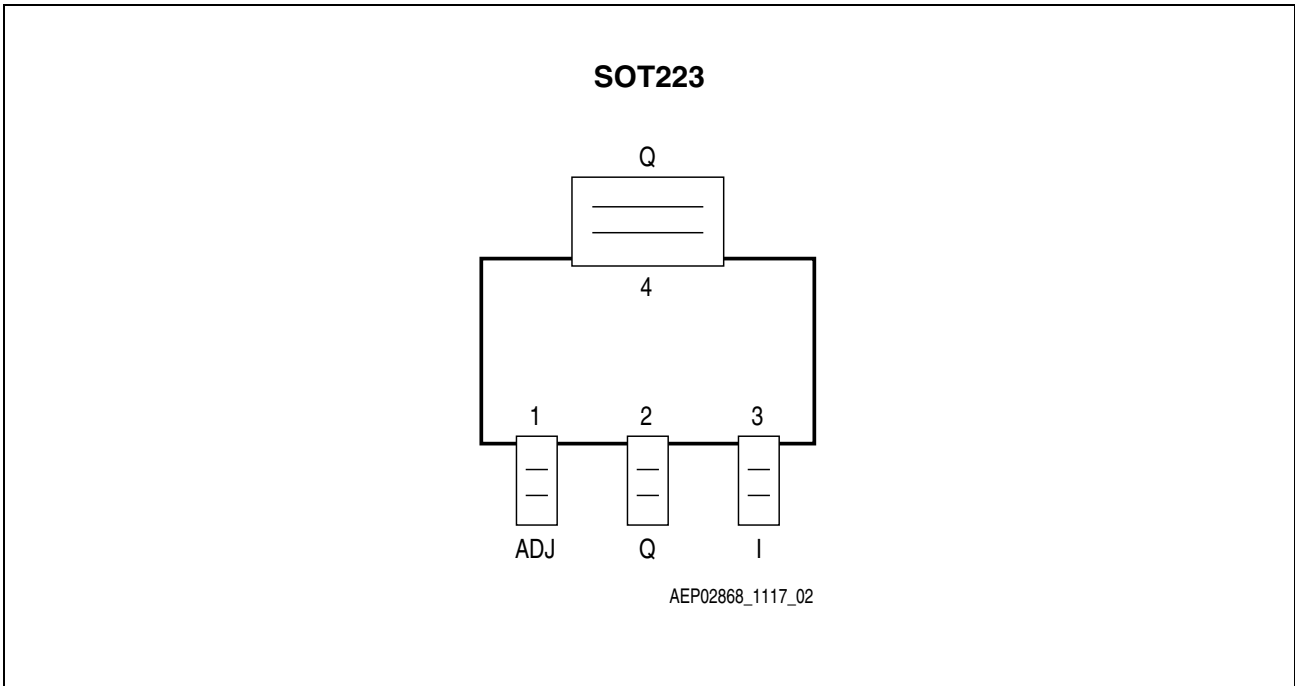

Figure 3 Pin Configuration IFX 1117 GSV (top view)

Table 2 Pin Definitions and Functions IFX 1117 GSV

Pin No.	Symbol	Function
1	ADJ	Adjust; defines output voltage level by external voltage divider between Q, ADJ and GND.
2	Q	Output; Connect output pin to GND via a capacitor $C_Q \geq 10 \mu\text{F}$ with $\text{ESR} \leq 20 \Omega$ (see also graph “Region of Stability”).
3	I	Input
4 (TAB)	Q	Output; Connect to pin 2 and heatsink area on PCB

Table 3 Absolute Maximum Ratings

Parameter	Symbol	Limit Values		Unit	Test Condition
		Min.	Max.		
Input - Output Voltage Difference (variable device only)					
Voltage	$V_I - V_Q$	-0.3	20	V	–
Input Voltage (fixed voltage version only)					
Voltage	V_I	-0.3	20	V	–
Output					
Voltage	V_Q	-0.3	20	V	–
Current	I_Q	–	–	–	Internally limited
ESD Rating					
Electrostatic discharge voltage	V_{ESD}	-2	2	kV	Human Body Model
Temperature					
Storage temperature	T_{stg}	-50	150	°C	–
Junction temperature	T_j	-40	150	°C	–

Note: Stresses above those listed here may cause permanent damage to the device. Exposure to absolute maximum rating conditions for extended periods may affect device reliability.

Table 4 Operating Range

Parameter	Symbol	Limit Values		Unit	Remarks
		Min.	Max.		
Input Voltage	V_I	$V_Q + V_{DR}$	15	V	–
Junction temperature	T_j	0	125	°C	–

Table 5 Thermal Resistance

Junction ambient	R_{thja}	–	164	K/W	PG-SOT223-4, footprint only.
		–	81	K/W	PG-SOT223-4, 300 mm ² heat sink area
Junction case	R_{thjc}	–	4	K/W	–

Note: In the operating range, the functions given in the circuit description are fulfilled.

Characteristics 3.3 V Fixed Output Voltage Device IFX 1117 GSV33
 $0\text{ }^{\circ}\text{C} < T_j < 125\text{ }^{\circ}\text{C}$; $V_I = 5\text{ V}$, $I_Q = 10\text{ mA}$; unless otherwise specified.

Parameter	Symbol	Limit Values			Unit	Measuring Conditions
		min.	typ.	max.		
Output voltage	V_Q	3.23 5	3.300	3.36 5	V	$0\text{ mA} \leq I_Q \leq 800\text{ mA}$ $4.7\text{ V} \leq V_I \leq 10\text{ V}$
Output voltage	V_Q	–	3.300	–	V	$0\text{ mA} \leq I_Q \leq 1000\text{ mA}$; $4.7\text{ V} \leq V_I \leq 15\text{ V}$
Line regulation	ΔV_Q	–	1	6	mV	$4.7\text{ V} \leq V_I \leq 15\text{ V}$
Load regulation	ΔV_Q	–	1	10	mV	$0\text{ mA} \leq I_Q \leq 800\text{ mA}$; ¹⁾
		–	2	–	mV	$0\text{ mA} \leq I_Q \leq 1.0\text{ A}$ ¹⁾
Drop voltage	V_{DR}	–	1.00	1.10	V	$I_Q = 100\text{ mA}$ ²⁾
Drop voltage	V_{DR}	–	1.05	1.15	V	$I_Q = 500\text{ mA}$ ²⁾
Drop voltage	V_{DR}	–	1.10	1.20	V	$I_Q = 800\text{ mA}$ ²⁾
Drop voltage	V_{DR}	–	1.30	1.40	V	$I_Q = 1.0\text{ A}$ ²⁾
Current consumption; $I_q = I_I - I_Q$	I_q	–	5	10	mA	$I_Q = 10\text{ mA}$
Temperature stability	ΔV_Q	–	16.5	–	mV	³⁾
Long Term Stability	–	–	0.3	–	%	³⁾
Current limit	I_{Qmax}	1100	–	2250	mA	$V_Q = 0.5\text{ V}$
RMS Output Noise	–	–	30	–	ppm	ppm of V_Q , $T_j = 25\text{ }^{\circ}\text{C}$ $10\text{ Hz} \leq f \leq 10\text{ kHz}$ ³⁾
Power Supply Ripple Rejection	$PSRR$	60	65	–	dB	$f_r = 120\text{ Hz}$, $V_r = 1\text{ V}_{PP}$ ³⁾

1) Measured at constant junction temperature

2) Drop voltage measured when the output voltage has dropped 100 mV from the nominal value obtained at $V_I = 5.0\text{ V}$.

3) Specified by design; not subject to production test.

Characteristics Adjustable Output Voltage Device IFX 1117 GSV
0 °C < T_j < 125 °C; V_I = 5 V, I_Q = 10 mA; unless otherwise specified.

Parameter	Symbol	Limit Values			Unit	Measuring Conditions
		min.	typ.	max.		
Reference voltage	V _Q	1.22 5	1.250	1.27 0	V	10 mA ≤ I _Q ≤ 800 mA; 1.4 V ≤ (V _I -V _Q) ≤ 10 V
Output voltage	V _Q	–	1.250	–	V	10 mA ≤ I _Q ≤ 1000 mA; 2.65 V ≤ V _I ≤ 15 V
Line regulation	ΔV _Q	–	0.035	0.2	% ¹⁾	1.5 V ≤ (V _I -V _Q) ≤ 13.75 V
Load regulation	ΔV _Q	–	0.2	0.4	% ¹⁾	10 mA ≤ I _Q ≤ 800 mA; ²⁾
		–	0.25	–	% ¹⁾	10 mA ≤ I _Q ≤ 1.0 A ²⁾
Drop voltage	V _{DR}	–	1.00	1.10	V	I _Q = 100 mA ³⁾
Drop voltage	V _{DR}	–	1.05	1.15	V	I _Q = 500 mA ³⁾
Drop voltage	V _{DR}	–	1.10	1.20	V	I _Q = 800 mA ³⁾
Drop voltage	V _{DR}	–	1.30	1.40	V	I _Q = 1.0 A ³⁾
Minimum Load Current ⁴⁾	I _q	–	1.7	5.0	mA	V _I = 15 V
Adjust Current	I _{ADJ}	–	100	120	μA	I _Q = 10 mA
Adjust Current Change	ΔI _{ADJ}	–	2	5	μA	1.4 V ≤ (V _I -V _Q) ≤ 13.6 V; 10 mA ≤ I _Q ≤ 800 mA
Temperature stability	ΔV _Q	–	0.5	–	% ¹⁾	⁵⁾
Long Term Stability	–	–	0.3	–	% ¹⁾	⁵⁾
Current limit	I _{Qmax}	1100	–	2250	mA	V _Q = 0.5 V
RMS Output Noise	–	–	30	–	ppm	ppm of V _Q , T _j = 25 °C 10 Hz ≤ f ≤ 10 kHz ⁵⁾
Power Supply Ripple Rejection	PSRR	65	70	–	dB	f _r = 120 Hz, V _r = 1 V _{PP} ⁵⁾

1) Related to V_Q

2) Measured at constant junction temperature

3) Drop voltage measured when the output voltage has dropped 100 mV from the nominal value obtained at V_I = 5.0 V.

4) Minimum load current required to maintain regulation

5) Specified by design; not subject to production test.

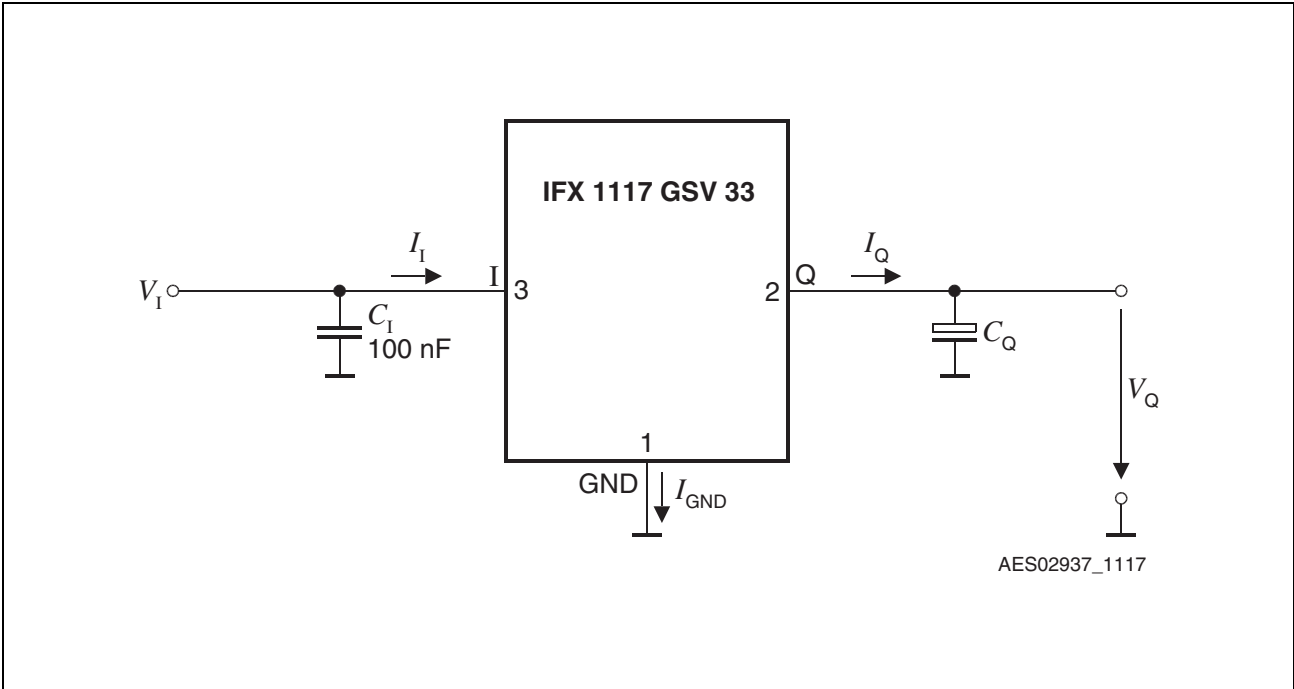

Figure 4 Measuring Circuit

Application Information

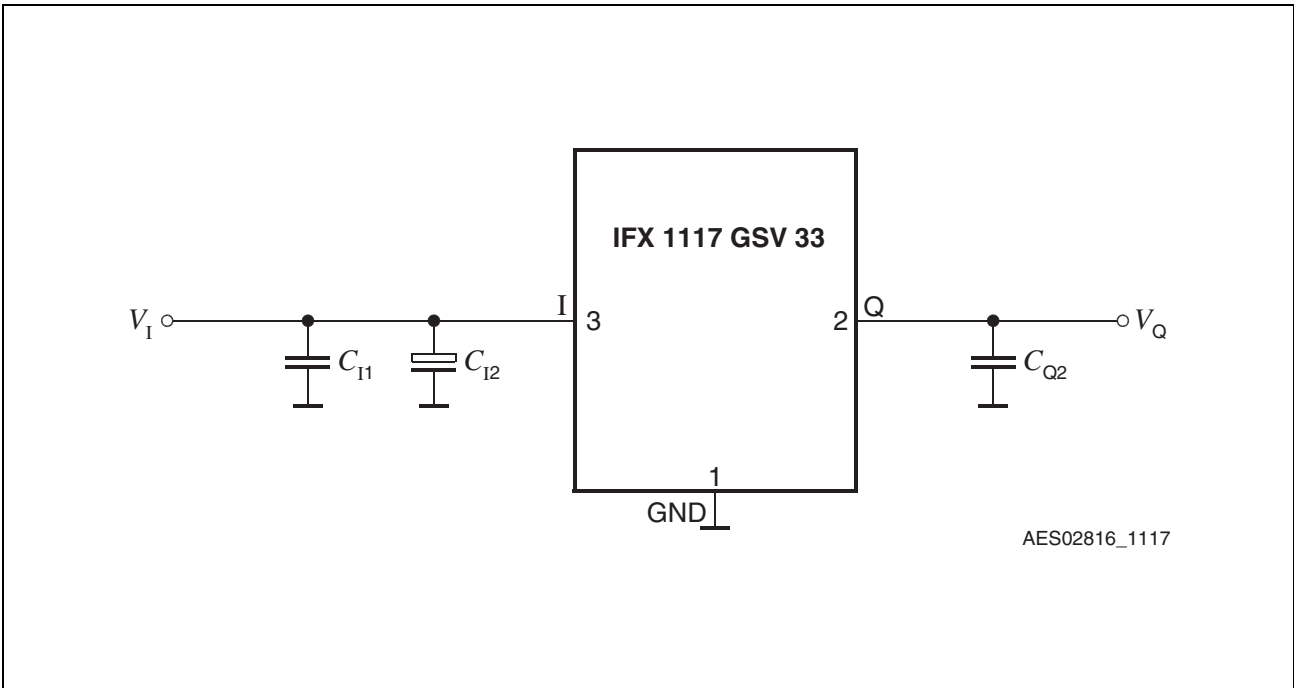

Figure 5 Typical Application Circuit IFX 1117 GSV33

Output

The IFX 1117 requires a 10 μF output capacitor with $\text{ESR} \leq 20 \Omega$ for the stability of the regulation loop. The use of a tantalum output capacitor is recommended.

For the adjustable device IFX 1117 GSV the output voltage level can be defined by a voltage divider between Q, ADJ and GND.

The output voltage calculates:

$$V_Q = V_{\text{REF}} \times \left(1 + \frac{R_2}{R_1}\right) + I_{\text{ADJ}} \times R_2 \quad (1)$$

At the input of the regulator a capacitor is recommended to compensate line influences. As a minimum a 100 nF ceramic input capacitor should be used. If the regulator is used in an environment with long input lines an input capacitance of 10 μF is suggested.

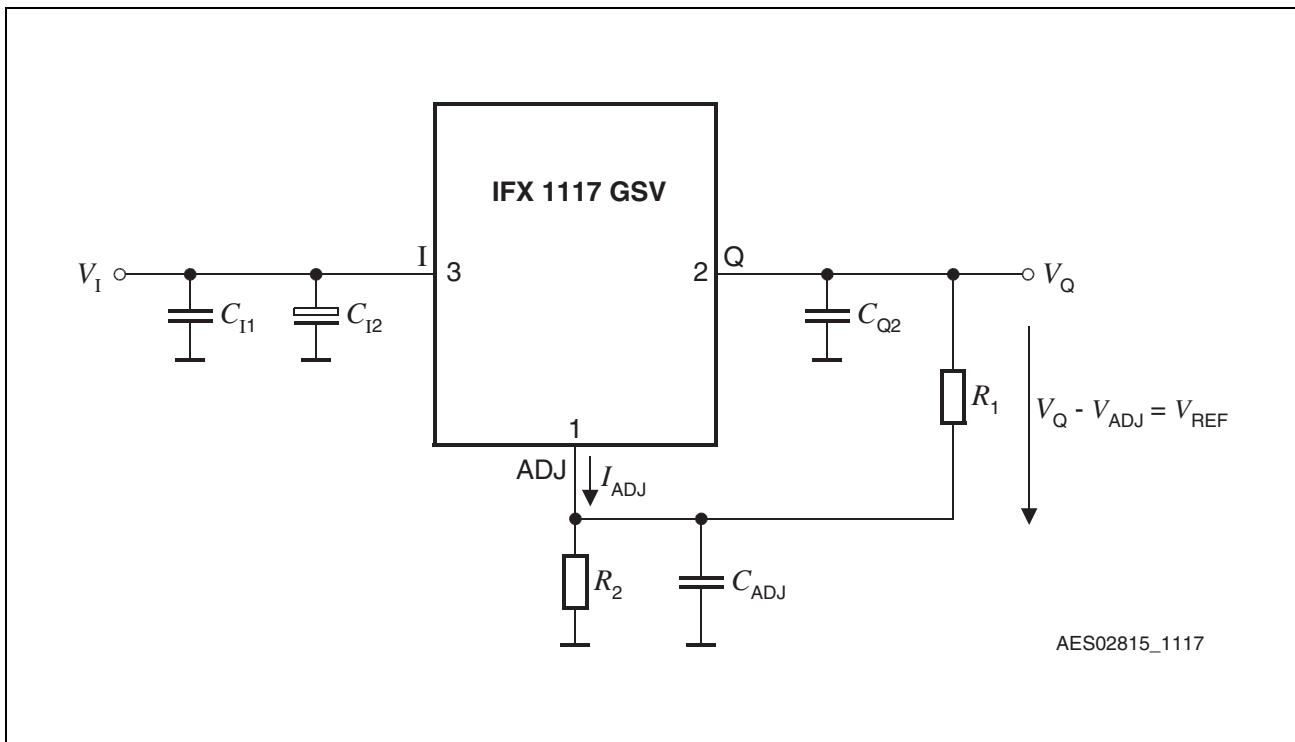
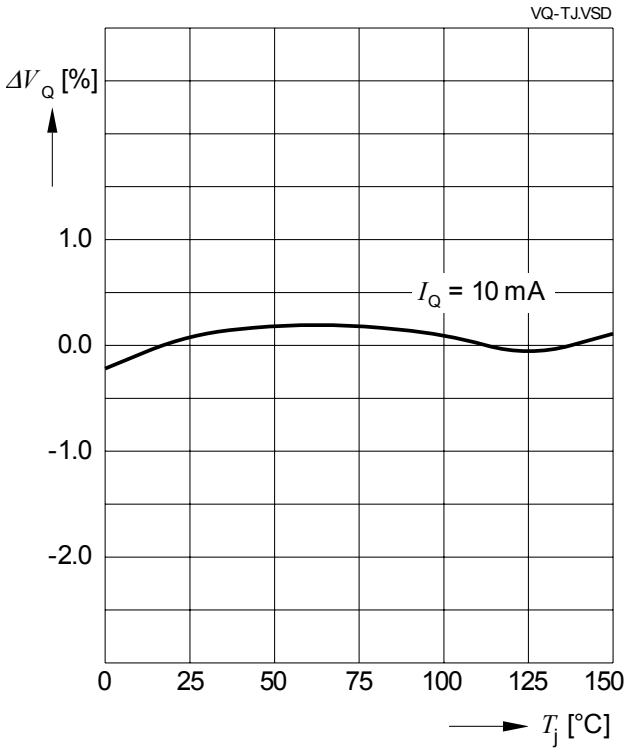

Figure 6 Typical Application Circuit IFX 1117 GSV

Typical Performance Characteristics

Output Voltage V_Q versus Junction Temperature T_j



Dropout Voltage V_{dr} versus Output Current I_Q

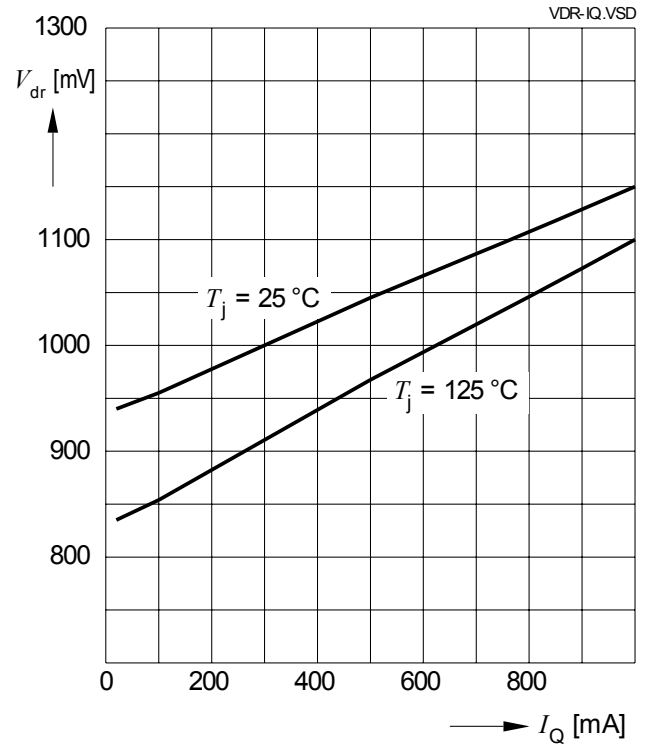

Dropout Voltage V_{dr} versus Junction Temperature T_j

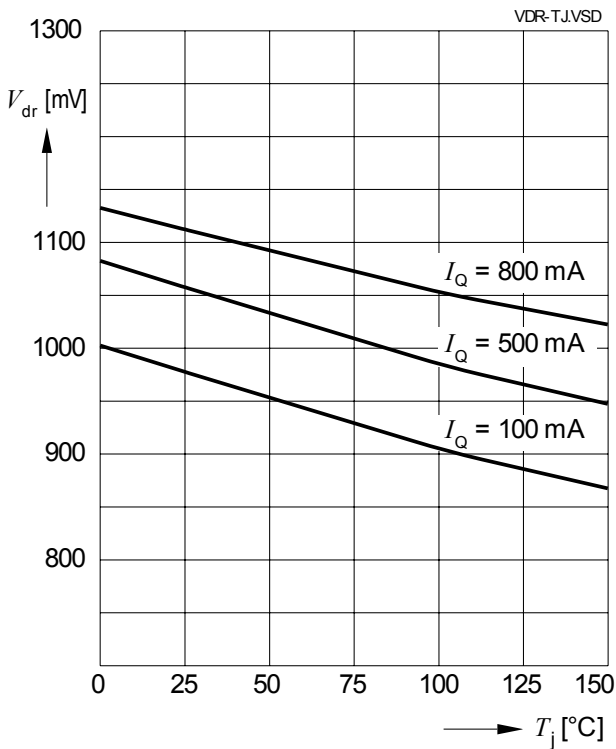

Maximum Output Current I_Q versus Junction Temperature T_j

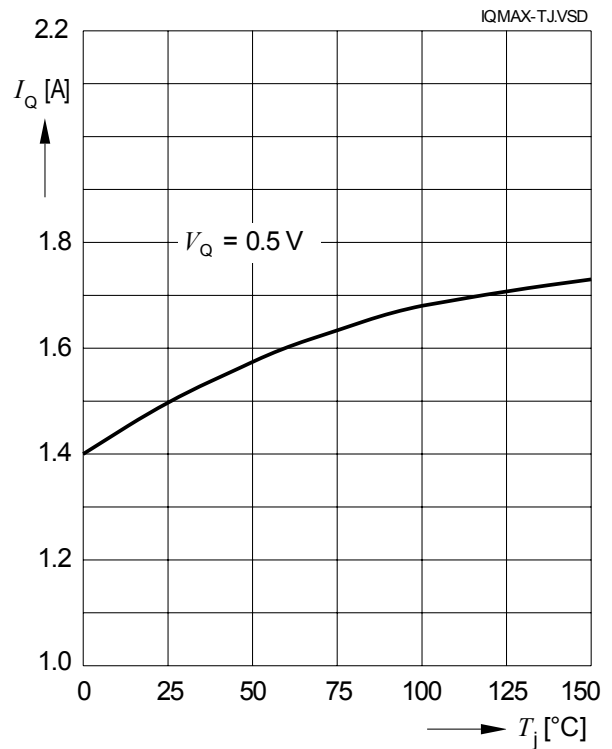

Typical Performance Characteristics

Adjust Pin Current I_{ADJ} versus Junction Temperature T_j

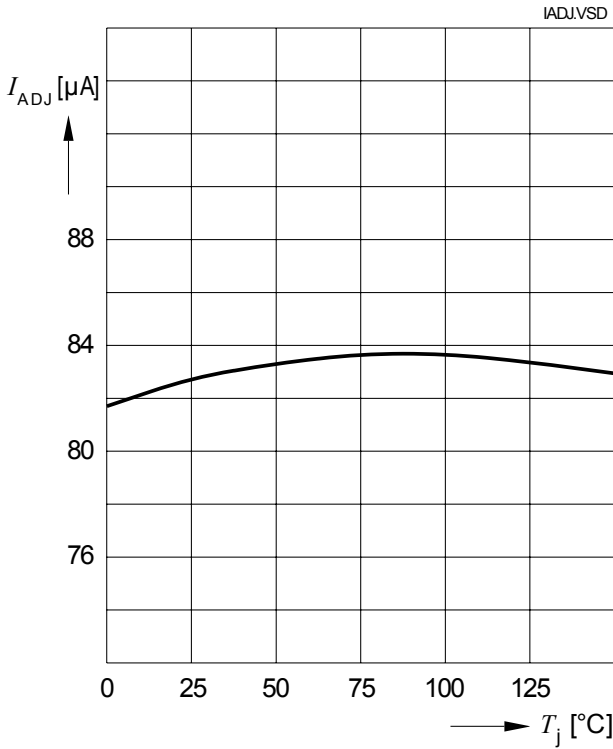

Power Supply Ripple Rejection $PSRR$ versus Frequency f

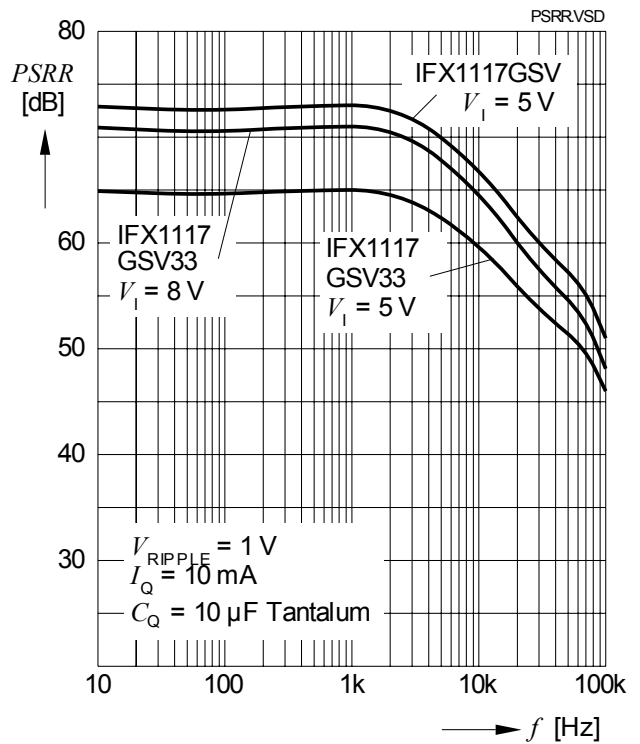

Region of Stability Version GSV33

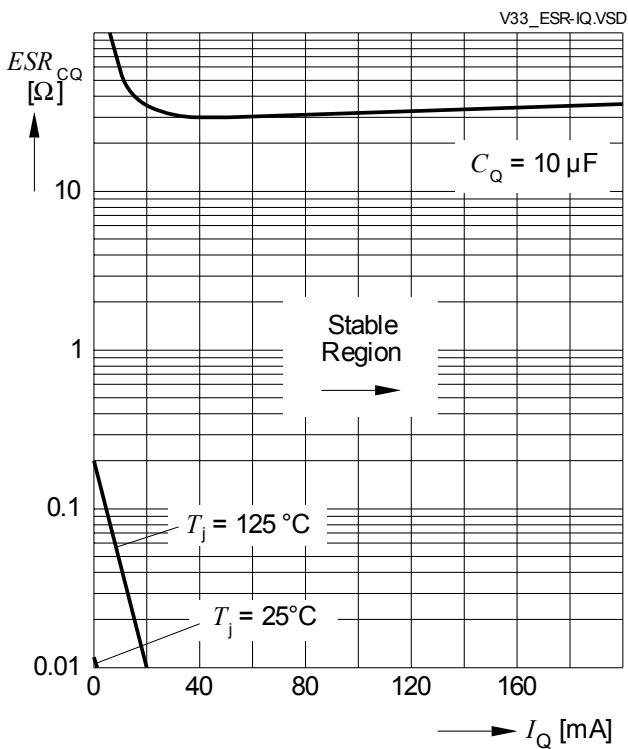

Region of Stability Version GSV

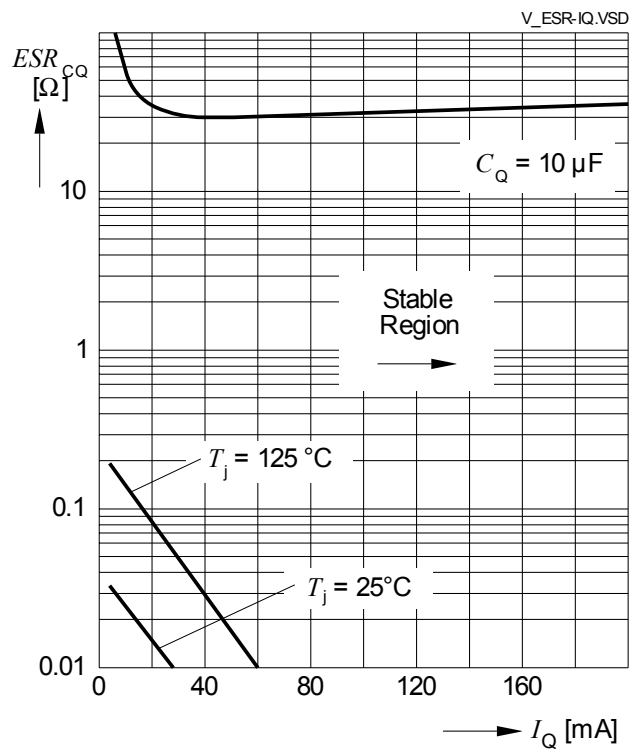

Typical Performance Characteristics

**Load Transient Response
Version GSV33**

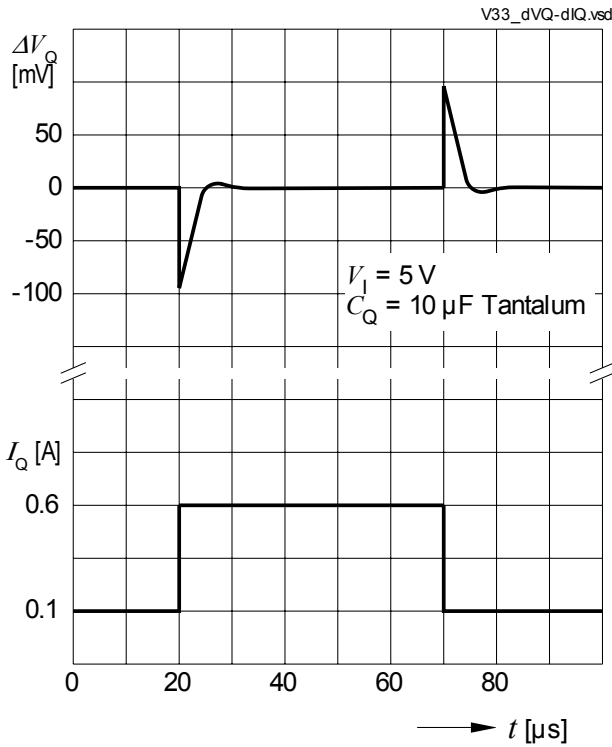

**Line Transient Response
Version GSV33**

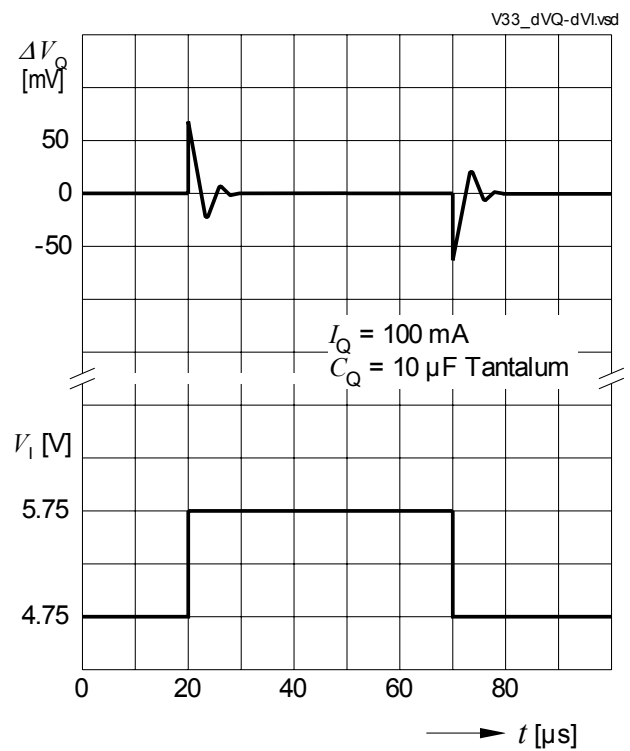

**Load Transient Response
Version GSV**

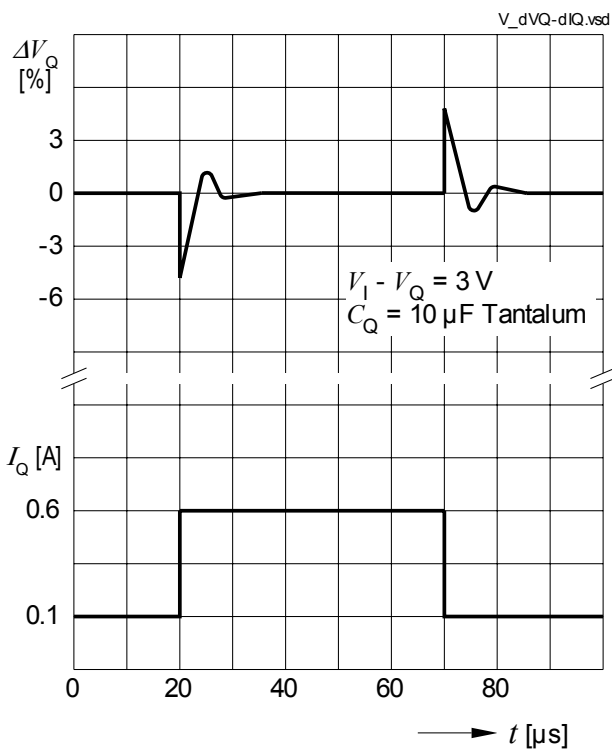

**Line Transient Response
Version GSV**

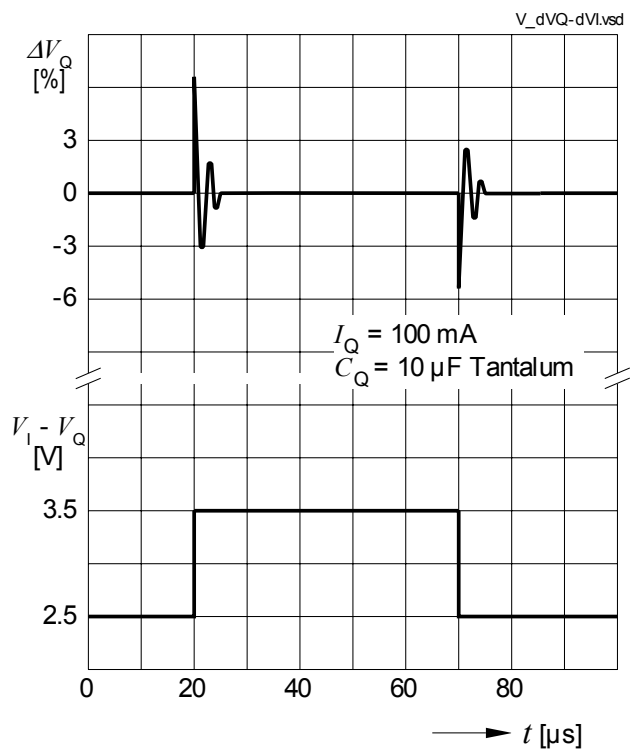

Package Outline

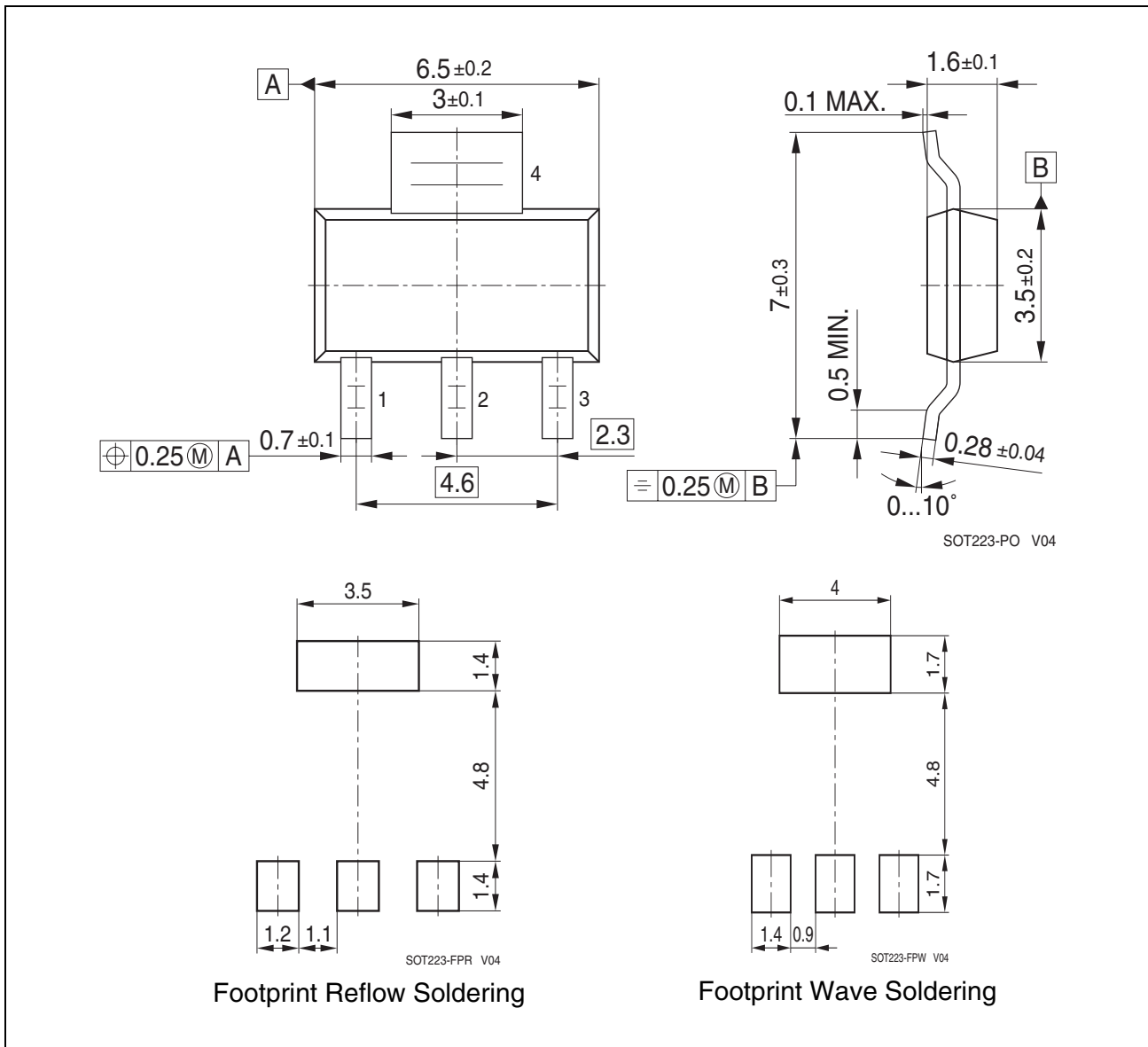

Figure 7 Outline and footprint PG-SOT223-4

Green Product (RoHS-Compliant)

To meet the world-wide customer requirements for environmentally friendly products and to be compliant with government regulations the device is available as a green product. Green products are RoHS-Compliant (i.e Pb-free finish on leads and suitable for Pb-free soldering according to IPC/JEDEC J-STD-020).

You can find all of our packages, sorts of packing and others in our Infineon Internet Page "Products": <http://www.infineon.com/products>.

SMD = Surface Mounted Device

Dimensions in mm

Revision History

Version	Date	Changes
Rev. 1.21	2009-09-04	Overview page: Inserted reference statement to TLE/TLF series.
Rev. 1.2	2008-08-08	Changed Package to "Green" Variant PG-SOT-223-4.
Rev. 1.1	2004-07-20	"Typical Performance Characteristics" graphs added.
Rev. 1.0	2004-06-01	Final Data Sheet

Edition 2009-09-04

**Published by
Infineon Technologies AG
81726 München, Germany
© Infineon Technologies AG 2009.
All Rights Reserved.**

Legal Disclaimer

The information given in this document shall in no event be regarded as a guarantee of conditions or characteristics ("Beschaffenheitsgarantie"). With respect to any examples or hints given herein, any typical values stated herein and/or any information regarding the application of the device, Infineon Technologies hereby disclaims any and all warranties and liabilities of any kind, including without limitation warranties of non-infringement of intellectual property rights of any third party.

Information

For further information on technology, delivery terms and conditions and prices please contact your nearest Infineon Technologies Office (www.infineon.com).

Warnings

Due to technical requirements components may contain dangerous substances. For information on the types in question please contact your nearest Infineon Technologies Office.

Infineon Technologies Components may only be used in life-support devices or systems with the express written approval of Infineon Technologies, if a failure of such components can reasonably be expected to cause the failure of that life-support device or system, or to affect the safety or effectiveness of that device or system. Life support devices or systems are intended to be implanted in the human body, or to support and/or maintain and sustain and/or protect human life. If they fail, it is reasonable to assume that the health of the user or other persons may be endangered.