

**PLEASE CHECK WWW.MOLEX.COM FOR LATEST PART INFORMATION**

**Part Number:** **0191930283**  
**Status:** **Active**  
**Description:** VersaKrimp™ Ring Tongue Terminal for 4 AWG Wire

**Documents:**

[Drawing \(PDF\)](#) [RoHS Certificate of Compliance \(PDF\)](#)

**Agency Certification**

CSA LR18689  
 UL E32244

**General**

Product Family Ring and Spade Terminals  
 Series [19193](#)  
 Crimp Quality Equipment Yes  
 Mil-Spec N/A  
 Product Name VersaKrimp™  
 Type Ring

**Physical**

Barrel Type Closed - Brazed  
 Insulation None  
 Material - Plating Mating Tin  
 Packaging Type Bag  
 Plating min: Mating (µin) 100  
 Plating min: Mating (µm) 2.5  
 Plating min: Termination (µin) 100  
 Plating min: Termination (µm) 2.5  
 Stud Size 3/8" (M9)  
 Termination Interface: Style Crimp or Compression  
 Wire Size AWG 4

**Material Info**

Old Part Number F-369-38

**Reference - Drawing Numbers**

Sales Drawing SD-19193-006

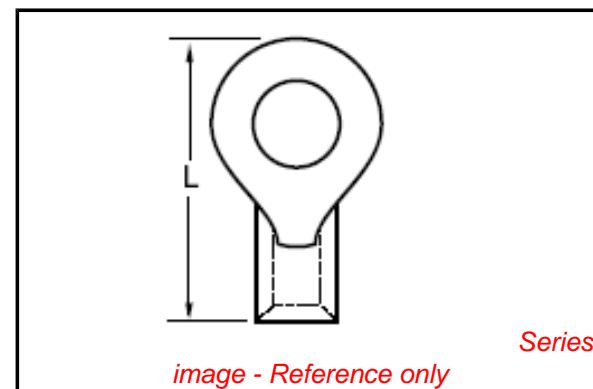

*image - Reference only*

**EU RoHS**

**ELV and RoHS  
 Compliant**  
**REACH SVHC  
 Contains SVHC: No**  
**Halogen-Free  
 Status  
 Not Reviewed**

**China RoHS**



**Need more information on product  
 environmental compliance?**

Email [productcompliance@molex.com](mailto:productcompliance@molex.com)  
 For a multiple part number RoHS Certificate of  
 Compliance, [click here](#)

Please visit the [Contact Us](#) section for any  
 non-product compliance questions.

**Search Parts in this Series**

[19193Series](#)

**Application Tooling | [FAQ](#)**

*Tooling specifications and manuals are  
 found by selecting the products below.  
 Crimp Height Specifications are then  
 contained in the Application Tooling  
 Specification document.*

**Global**

Description	Product #
Putt Pump Dieless Head System	<a href="#">0192860065</a>
Manual Putt Pump Hydraulic System, Die set required	<a href="#">0192860117</a>
Die Set (large) for the HHLS Hydraulic Crimper	<a href="#">0192900007</a>
Hand Crimp Tool	<a href="#">0640013900</a>

**PLEASE CHECK [WWW.MOLEX.COM](http://WWW.MOLEX.COM) FOR LATEST PART INFORMATION**

Customer Dwg:

MATERIAL: Copper  
 PLATING: Electro-Tin  
 STUD SIZE: "D" ±.005

- 10 - .198
- 14 - .265
- 56 - .328
- 38 - .390
- 76 - .453
- 12 - .515
- 58 - .656
- 34 - .781
- 209 = .209
- 413 = .413

VERSAKRIMP

BRAZE SEAM

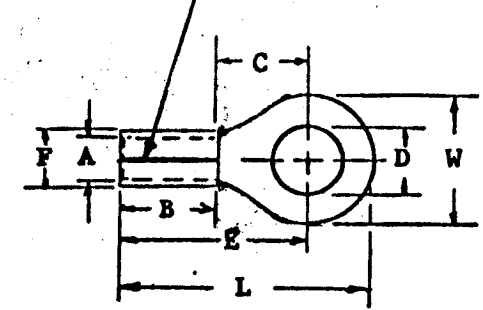

Customer Dimensions

Part No.	Wire Size	"W"	"C" Min	"E" Max	"B" Min	"L" Max	"A" Min	Stock Thkns. (A)	"F" Max	AVAILABLE STUD SIZE
F-366-	#4	.652 .678	.520	1.028	.425	1.385	.280	REF. .075	.470	209, 413 10, 14, 56, 38, 76, 12,
F-367-	#4	.465 .485	.520	1.028	.425	1.288	.280	REF. .075	.470	10, 14, 56
F-369-	#4	.875 .895	.989	1.497	.425	1.970	.280	REF. .075	.470	14, 56, 38, 76, 12, 58
F-370-	#4	1.250 1.270	.989	1.497	.425	2.158	.280	REF. .075	.470	14, 56, 38, 76, 12, 58, 34

For parts to be on tape add "T" at end of part number.

REVISION	SCALE: NONE	DATE
	DRWN. BY: LEM	3/2/70
	CHKD. BY:	
	APPRD. BY:	
A	DRAWING NO.:	



TITLE: "F" RING TONGUE TERMINAL

DIMENSIONAL TOLERANCE UNLESS OTHERWISE SPECIFIED		
FRAC.	DEC.	ANG.
±	±	±