

isc Silicon NPN Power Transistor

2SC3570

DESCRIPTION

- Collector-Emitter Sustaining Voltage
: $V_{CEO(SUS)} = 400V(\text{Min.})$
- Low Collector Saturation Voltage
- Fast Switching Speed

APPLICATIONS

- Designed for switching regulator, DC-DC converter and high frequency power amplifier applications.

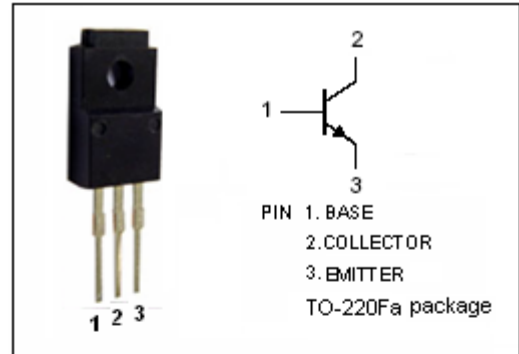

ABSOLUTE MAXIMUM RATINGS($T_a=25^\circ\text{C}$)

SYMBOL	PARAMETER	VALUE	UNIT
V_{CBO}	Collector-Base Voltage	500	V
V_{CEO}	Collector-Emitter Voltage	400	V
V_{EBO}	Emitter-Base Voltage	8	V
I_C	Collector Current-Continuous	5	A
I_{CM}	Collector Current-Peak	10	A
I_B	Base Current-Continuous	2.5	A
P_C	Total Power Dissipation @ $T_C=25^\circ\text{C}$	25	W
T_J	Junction Temperature	150	$^\circ\text{C}$
T_{stg}	Storage Temperature Range	-55~150	$^\circ\text{C}$

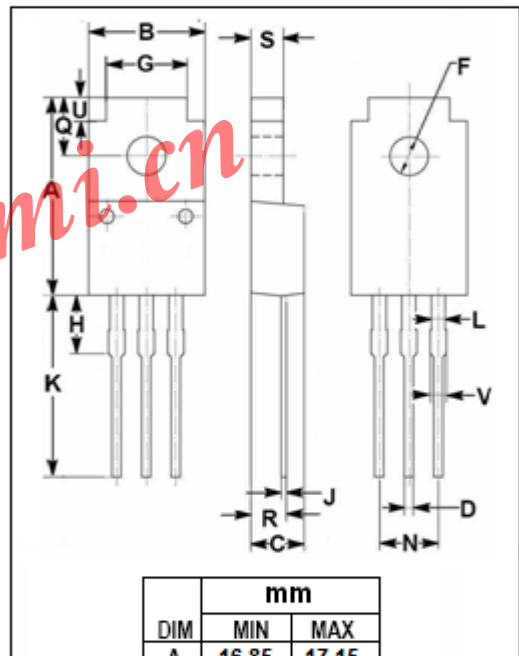

isc Silicon NPN Power Transistor

2SC3570

ELECTRICAL CHARACTERISTICS

 $T_C=25^\circ\text{C}$ unless otherwise specified

SYMBOL	PARAMETER	CONDITIONS	MIN	MAX	UNIT
$V_{CEO(SUS)}$	Collector-Emitter Sustaining Voltage	$I_C=2.0A; I_B=0.4A, L=1mH$	400		V
$V_{CEX(SUS)-1}$	Collector-Emitter Sustaining Voltage	$I_C=2.0A; I_{B1}=-I_{B2}=0.4A, L=180\mu H, \text{clamped}$	450		V
$V_{CEX(SUS)-2}$	Collector-Emitter Sustaining Voltage	$I_C=4A; I_{B1}=0.8A; I_{B2}=-0.4A, L=180\mu H, \text{clamped}$	400		V
$V_{CE(sat)}$	Collector-Emitter Saturation Voltage	$I_C=2A; I_B=0.4A$		1.0	V
$V_{BE(sat)}$	Base-Emitter Saturation Voltage	$I_C=2A; I_B=0.4A$		1.2	V
I_{CBO}	Collector Cutoff Current	$V_{CB}=400V; I_E=0$		10	μA
I_{CER}	Collector Cutoff Current	$V_{CE}=400V; R_{BE}=51\Omega, T_a=125^\circ\text{C}$		1.0	mA
I_{CEX}	Collector Cutoff Current	$V_{CE}=400V; V_{BE(off)}=-1.5V, T_a=125^\circ\text{C}$ $V_{CE}=400V; V_{BE(off)}=-1.5V, T_a=125^\circ\text{C}$		10 1.0	μA mA
I_{EBO}	Emitter Cutoff Current	$V_{EB}=5V; I_C=0$		10	μA
h_{FE-1}	DC Current Gain	$I_C=0.5A; V_{CE}=5V$	20	80	
h_{FE-2}	DC Current Gain	$I_C=2.0A; V_{CE}=5V$	10		

Switching times

t_{on}	Turn-on Time	$I_C=2A, R_L=75\Omega, I_{B1}=-I_{B2}=0.4A, V_{CC}\approx 150V$		1.0	μs
t_{stg}	Storage Time			2.0	μs
t_f	Fall Time			0.7	μs

◆ h_{FE-2} Classifications

M	L	K
20-40	30-60	40-80