

Multi-mode SCSI Terminator

FEATURES

- Fully compliant with Ultra160/m SCSI, Ultra2 and Ultra3 standards.
- Auto-selection Multi-Mode SE or LVD termination for 9 signal line pairs.
- 5 V operation
- Built in thermal shutdown circuitry
- Supports Master/Slave input.
- SCSI bus hot-plug compatible.
- Supports active-negation drive.

DESCRIPTION

The SS7500 is a multimode SCSI terminator that conforms to the SCSI (SP2) specification which is designed for low voltage differential (LVD) termination.

The SS7500 provides backward compatibility to the SCSI and SCSI-2 specifications.

Multimode function sets up the use of legacy devices on the bus without changing any hardware setting. Automatic selection is made by voltage detection on the diffsense line. If the device is connected to an LVD-only bus, the SS7500 will use LVD termination. If the device is connected in a Single Ended mode, the SS7500 will be connected in a SE termination. The SCSI termination architecture uses high speed elements for the design, therefore providing fast response time.

PACKAGE PIN OUT

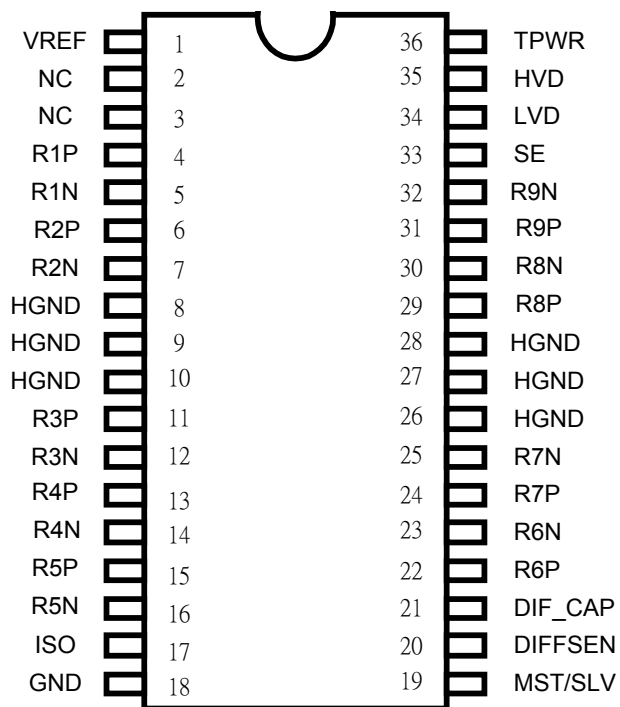

SS7500

PIN DESCRIPTION

PIN	SYMBOL	DESCRIPTION
36	TPWR	Vin 5V supply. Connect to SCSI bus power line.
1	VREF	Reference Voltage. Must be decoupled with a 4.7uF as shown in Figure 1.
2,3	NC	Do not connect any signal to this pin.
8,9,10 26,27,28	HGND	Heat Sink Ground. Connect to large area PC board ground trace in order to increase power dissipation.
4,6,11 13,15,22 24,29,31	RxP	Signal Terminator. Line for single ended or positive line for differential mode.
5,7,12 14,16,23 25,30,32	RxN	Single Terminator. Line for single ended or negative line for differential mode.
17	ISO	Shuts down the terminator when pull high.
18	GND	Signal Ground.
19	MST/SLV	Mode select pin. Master mode will enable the DIFFSEN drive SCSI bus if this signal ties high.
20	DIFFSEN	This signal will drive 1.3V to the SCSI bus during the Master mode in order to detect which type of device is connected to the SCSI bus.
21	DIF_CAP	This pin should be connected to a 0.1uF capacitor to ground and 20K resistor to SCSI bus DIFFSEN line for DIFFSEN filter.
33	SE	Single ended. Indicates SE device is on the SCSI bus when this pin is active.
34	LVD	Low Voltage Differential. Indicates the terminator is in LVD operation.
35	HVD	High Voltage Differential. Indicates the HVD device is detected and terminator is in shut down mode.

DC CHARACTERISTICS:

PARAMETER	SYMBOL	MIN	TYP	MAX	UNITS
TPWR Current	Itpwr		35		mA
Input Leakage Current High	Iih	0			uA
Input Leakage Current Low	Iil			1.0	uA
Output Current High Vout = 2.4 V	Ioh	0			mA
Output Current Low Vout = 0.4V	Iol	4.0			mA
DIFFSEN Output Voltage	Vov	1.2		1.4	V
DIFFSEN Source Current	Isc		5	15	mA
DIFFSEN Sink Current	Isi	20		200	uA
DIFFSEN SE Voltage Range	Vse	-0.3		0.5	V
DIFFSEN LVD Voltage Range	Vlvd	0.7		1.9	V
DIFFSEN HVD Voltage Range	Vhvd	2.4		Vtpwr+0.3	V
Operating Temperature	Ta	0		70	°C

Single Ended Characteristics

PARAMETER	SYMBOL	MIN	TYP	MAX	UNITS
SE Termination Resistance	Rse	104.5	110	115.5	Ω
SE Voltage Reference	Vref	2.70		3.00	V
SE Output Current	Ioc			25.4	mA

LVD Characteristics

PARAMETER	SYMBOL	MIN	TYP	MAX	UNITS
Differential Mode Termination Resistance	Rd	100		110	Ω
Common Mode Termination Resistance	Rc	110	226	300	Ω
Differential Mode Bias All lines open	Vdb	100		125	mV
Common Mode Bias	Vcb	1.125		1.375	V

REGULATOR Characteristics

(0°C to 70°C)

PARAMETER	SYMBOL	MIN	TYP	MAX	UNITS
Source Current	Isour		200	230 Vout=0.2v	mA
Sink Current	Isink	100	200		mA

NOTE: Unless otherwise specified, these specifications apply over the operating ambient temperature range from 0°C to 70°C.

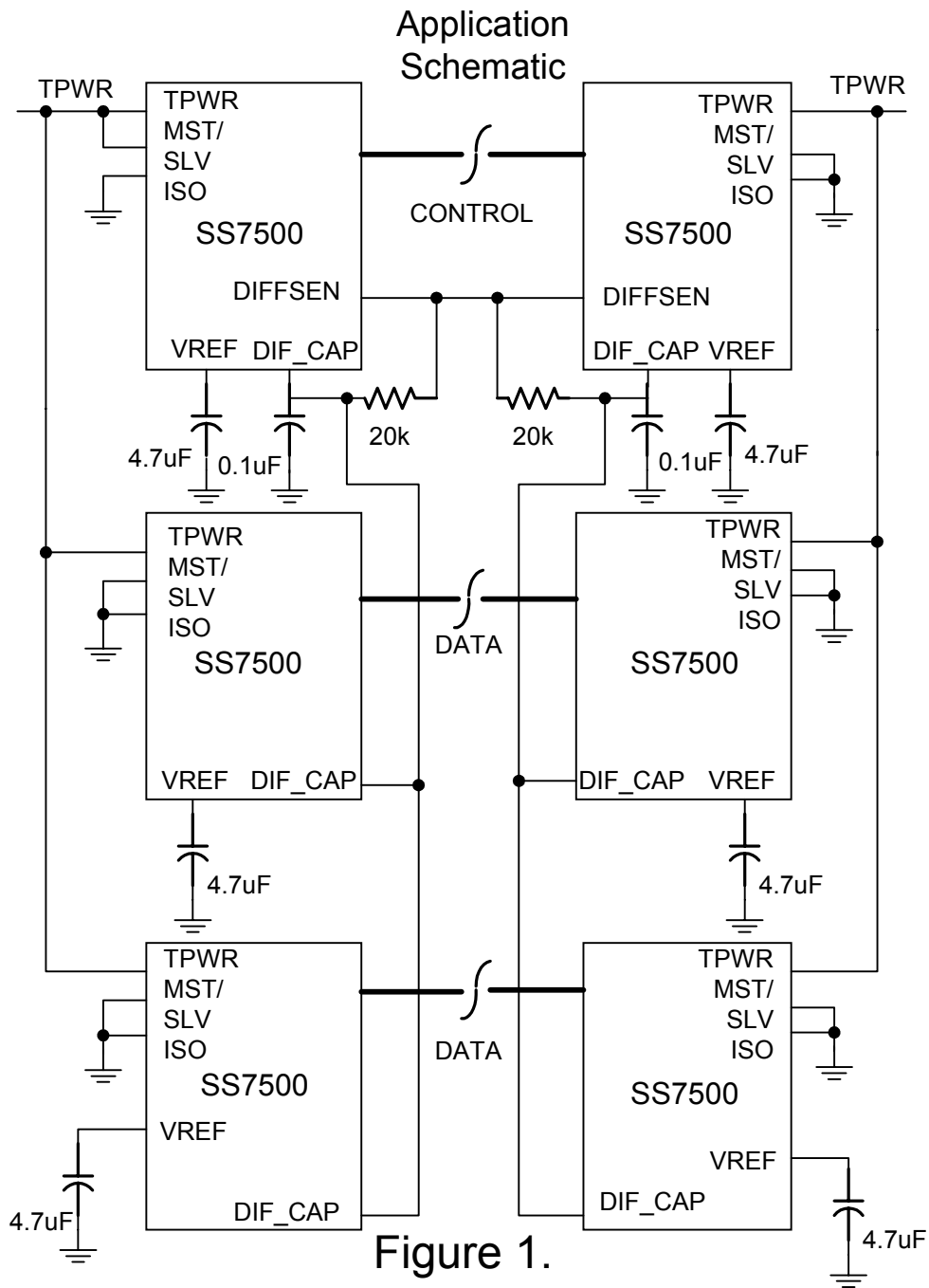

Package Dimension

SSOP-36

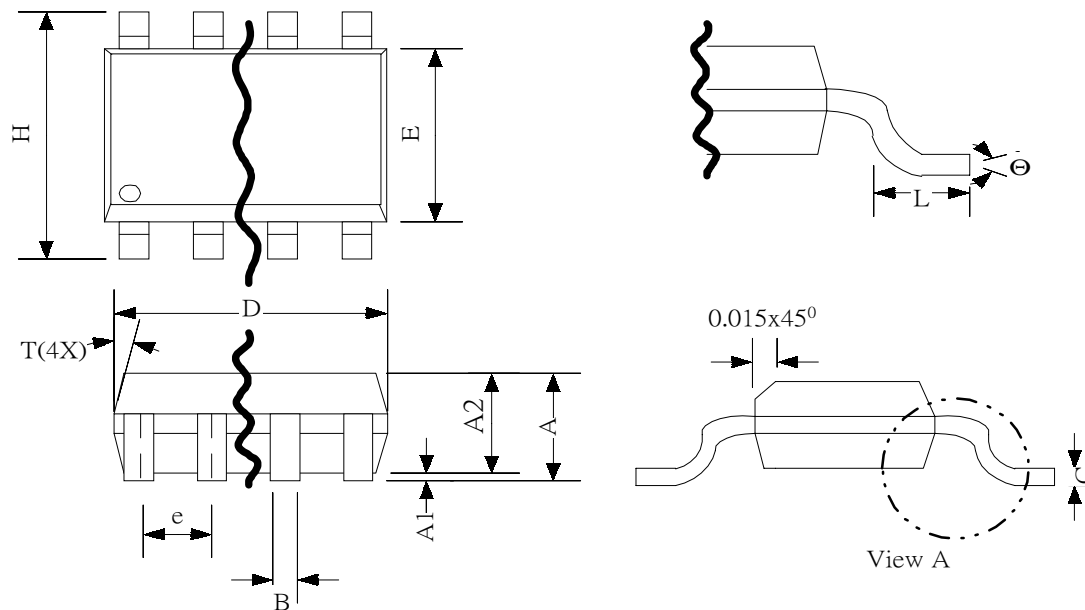

SYMBOL	MILLIMETERS		INCHES	
	MIN	MAX	MIN	MAX
A	2.41	2.59	0.095	0.110
A1	0.20	0.40	0.008	0.016
A2	2.26	2.52	0.089	0.099
B	0.30	0.45	0.012	0.018
C	0.127	0.254	0.005	0.010
D	15.75	16.00	0.620	0.630
E	7.391	7.595	0.291	0.299
e	0.8BSC		0.032BSC	
H	10.033	10.668	0.395	0.420
L	0.508	1.016	0.020	0.040
T	----	0.10	----	0.004
Θ	0°	8°	0°	8°

Information furnished by Silicon Standard Corporation is believed to be accurate and reliable. However, Silicon Standard Corporation makes no guarantee or warranty, express or implied, as to the reliability, accuracy, timeliness or completeness of such information and assumes no responsibility for its use, or for infringement of any patent or other intellectual property rights of third parties that may result from its use. Silicon Standard reserves the right to make changes as it deems necessary to any products described herein for any reason, including without limitation enhancement in reliability, functionality or design. No license is granted, whether expressly or by implication, in relation to the use of any products described herein or to the use of any information provided herein, under any patent or other intellectual property rights of Silicon Standard Corporation or any third parties.