



DESCRIPTION

PT2386 is an enhanced 3D Audio Effect IC utilizing CMOS Technology specially designed for the new generation of audio equipments. PT2386 features a bass booster function as well as the latest PTC 3D Audio Technology, thereby, guaranteeing highly powerful, extensive and true-to-life stereo sound stage effect. Furthermore, it does not need any additional complex external circuits making it very easy to design into any audio equipment products. Housed in 18 pins DIP package, PT2386 can operate at a wide operating voltage range and has low power consumption. Pin assignments and application circuit are optimized for easy PCB layout and cost saving benefits.

FEATURES

- CMOS technology
- Wide operating voltage Range: VDD=4V to 10V
- Low power consumption
- Very low total harmonic distortion: THD < 0.01%
- Wide output voltage range: greater than 3Vrms
- PTC 3D audio technology
- Built-in 3D LED driver
- 3D effect switching mode: direct or cyclic
- Least external components

APPLICATIONS

- Multi-media audio equipment
- Home audio equipment
- Portable audio equipment
- Car audio equipment
- Other audio equipment



BLOCK DIAGRAM

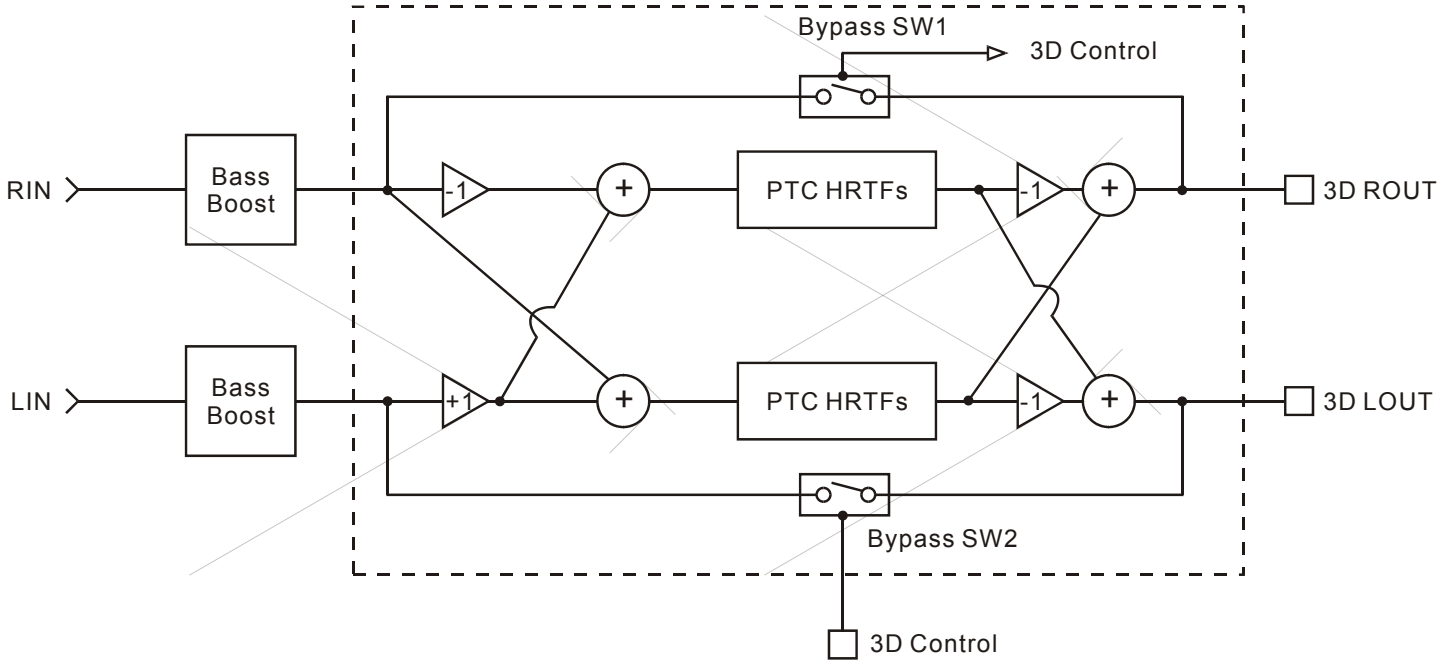



PIN CONFIGURATION

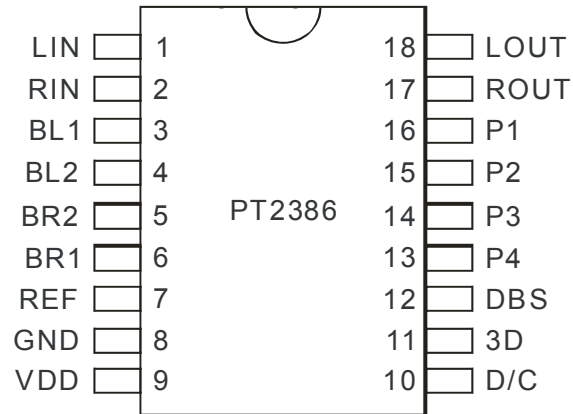



PIN DESCRIPTION

Pin Name	I/O	Description	Pin No.
LIN	I	Left channel input pin	1
RIN	I	Right channel input pin	2
BL1	O	Left channel bass booster pin 1 Connect an external capacitor to this pin	3
BL2	I	Left channel bass booster pin 2 Connect an external capacitor to this pin	4
BR2	I	Right channel bass booster pin 2 Connect an external capacitor to this pin	5
BR1	O	Right channel bass booster pin 1 Connect an external capacitor to this pin	6
REF	-	Reference voltage pin	7
GND	-	Ground	8
VDD	-	Positive power supply	9
D/C	I	3D effect switch mode select pin	10
3D	I/O	3D switch/3D LED driver pin	11
DBS	O	3D capacitor pin 1 Connect an external capacitor to this pin	12
P4	I/O	3D capacitor pin 2 Connect an external capacitor to this pin	13
P3	I/O	3D capacitor pin 2 Connect an external capacitor to this pin	14
P2	I/O	3D capacitor pin 3 Connect an external capacitor to this pin	15
P1	I/O	3D capacitor pin 3 Connect an external capacitor to this pin	16
ROUT	O	Right channel output pin	17
LOUT	O	Left channel output pin	18



FUNCTION DESCRIPTION

3D EFFECT ACTIVATION

The 3D effect function is controlled by the 3D Pin. The D/C Pin is used to select the mode of which the 3D effect function is activated. PT2386 provides two ways to activate the 3D effect function, namely: Direct or Cyclic Mode.

CYCLIC MODE

When the D/C Pin is connected to VDD, the Cyclic Mode is selected. Please refer to the diagram below.

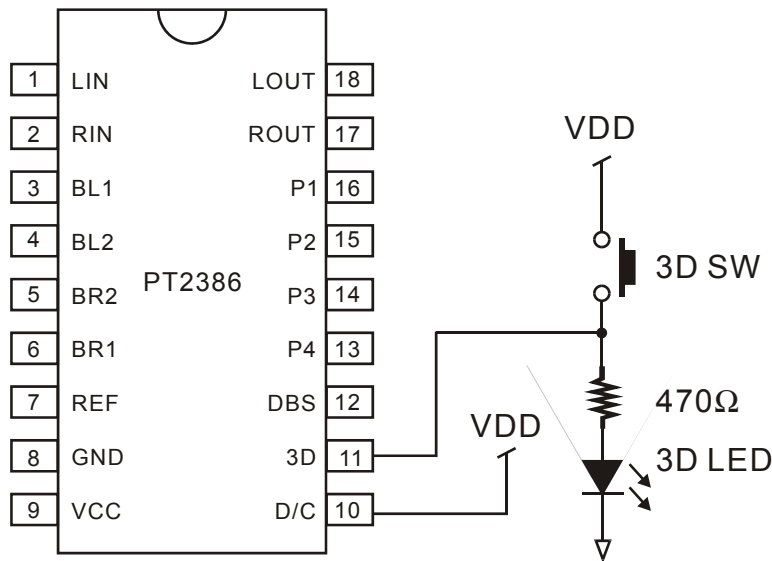

The 3D Switch toggles between activating and deactivating the 3D effect function. Under this mode, a 3D LED Display Indicator can be connected. When the 3D effect function is enabled, the LED is displayed. To make sure that the 3D effect function switching operation will work properly, the 3D pin trigger voltage value must not be less than 0.9VDD.



3D Effect IC

PT2386

DIRECT MODE

When the D/C Pin is connected to the Ground, the Direct Mode is selected. Please refer to the diagram below.

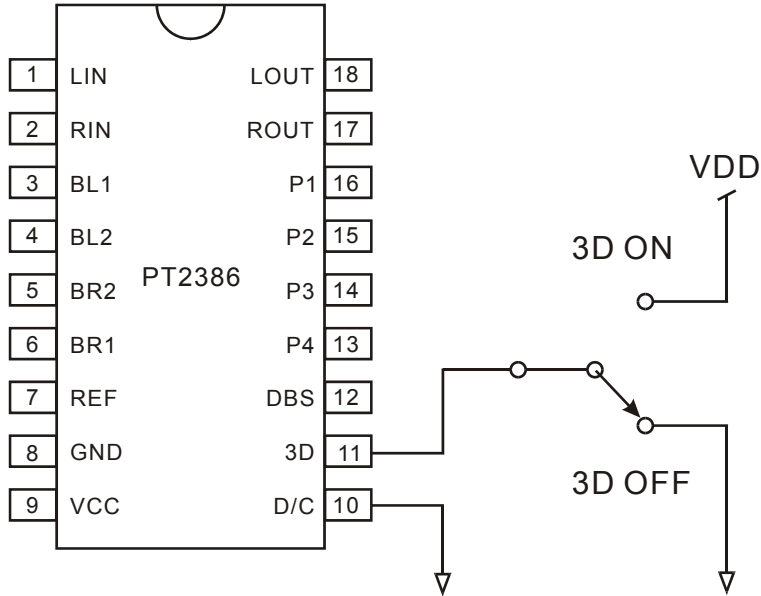

Under this condition, when the 3D pin is connected to VDD, the 3D effect function is activated. When the 3D Pin is connected to Ground, the 3D effect function is disabled. To make sure that the 3D effect function switching operation will work properly, the 3D pin trigger voltage value must not be less than 0.6VDD.



3D BASS BOOSTER

The 3D effect function and the bass booster feature can be activated at the same time. Please refer to the diagram below

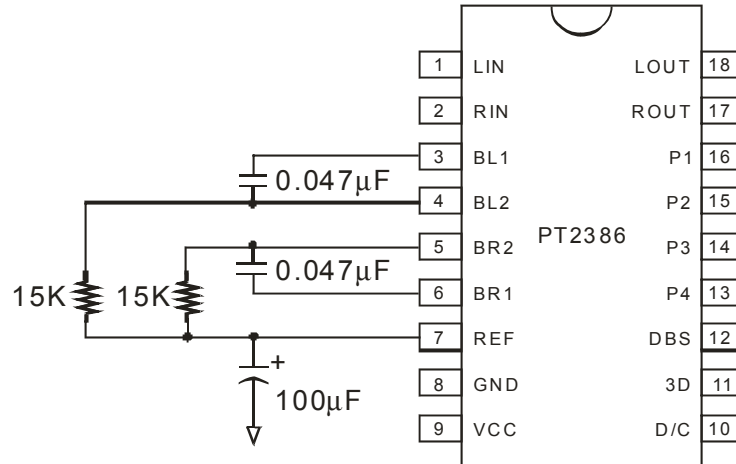

The bass booster level can be adjusted by changing the values of the external components (resistor/capacitor) connected to the Bass Booster Pins (BL1, BL2, BR1, BR2). If the value of the resistors connected to BR2, BL2 are decreased, the Bass Booster gain will increase. The typical resistor value is 15KΩ.

Decreasing the value of the capacitance connected to BL1, BL2, BR1, BR2 will increase the bass booster frequency range. Please refer to the diagrams below.

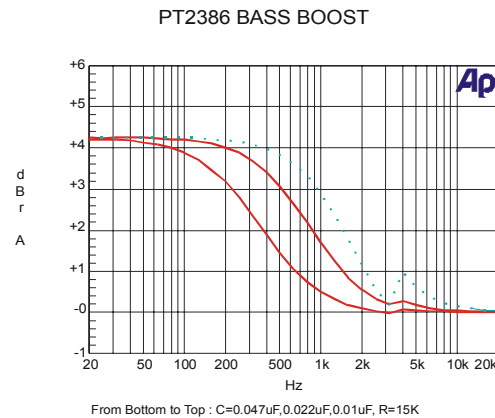
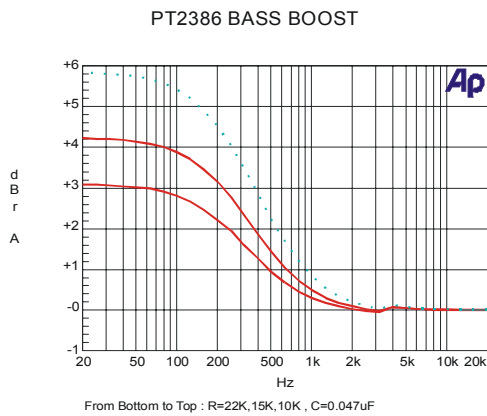

In order to avoid output clipping, it is recommended that the input signal be limited when the bass booster function is enabled. If the 3D function is switched ON and the bass booster function is not needed, then the bass booster pins -- BL1, BL2, BR1, BR2 must be "open".



SIGNAL OUTPUT PHASE

The input/output interval phase of PT2386 is 180° inverting when the 3D effect is either turned ON or OFF. For audio system design having more than 2 channels, it is recommended that the phase between each channels be given special attention.



ABSOLUTE MAXIMUM RATINGS

Parameter	Symbol	Rating	Unit
Power supply voltage	V_{DD}	12	V
Input voltage	V_I	-0.3 to $V_{DD}+0.3$	V
Operating temperature	T_{opr}	-40 to +85	°C
Storage temperature	T_{stg}	-65 to +150	°C

ELECTRICAL CHARACTERISTICS

(Unless otherwise specified, $V_{DD}=9V$, $V_{in}=1V_{rms}$, $F=1KHz$, $T_a=25^{\circ}C$)

Parameter	Symbol	Conditions	Min.	Typ.	Max.	Unit
Operating voltage	V_{DD}		4	9	10	V
Operating current	I_{CC}	$V_{DD}=5V$, $V_{in}=0V$	3	4	-	mA
		$V_{DD}=9V$, $V_{in}=0V$	7	10	14	
Maximum output voltage	V_{Omax}	$V_{DD}=5V$, $R_{LOAD}=10K\Omega$, THD=1%	-	1.1	1.2	mA
		$V_{DD}=9V$, $R_{LOAD}=10K\Omega$, THD=1%	-	3.0	3.2	
Maximum input voltage	V_{Imax}	$V_{DD}=5V$, 3D=OFF	-	0.9	-	Vrms
		$V_{DD}=9V$, 3D=OFF	-	2.5	-	
Voltage gain	A_V	3D=OFF	-	2	-	dB
Total harmonic distortion	THD	A-weighting	-	0.005	0.01	%
Signal-to-noise ratio	S/N	A-weighting	85	90	95	dB
Channel separation	S_c		-	85	-	dB
Input impedance	R_{IN}	$V_{in}=1V_{rms}$	40	47	55	K Ω
Output impedance	R_{OUT}	$V_{out}=1V_{rms}$	290	400	-	Ω
“High” level input voltage (3D pin)	V_{IH3D}	D/C pin=VDD	-	0.9	-	V_{DD}
		D/C pin=GND	-	0.5	-	
“Low” level input voltage (3D pin)	V_{IL3D}	D/C pin=GND	-	0.2	-	V_{DD}



APPLICATION CIRCUIT

(CYCLIC MODE WITH 3D EFFECT & BASS BOOSTER FUNCTION)

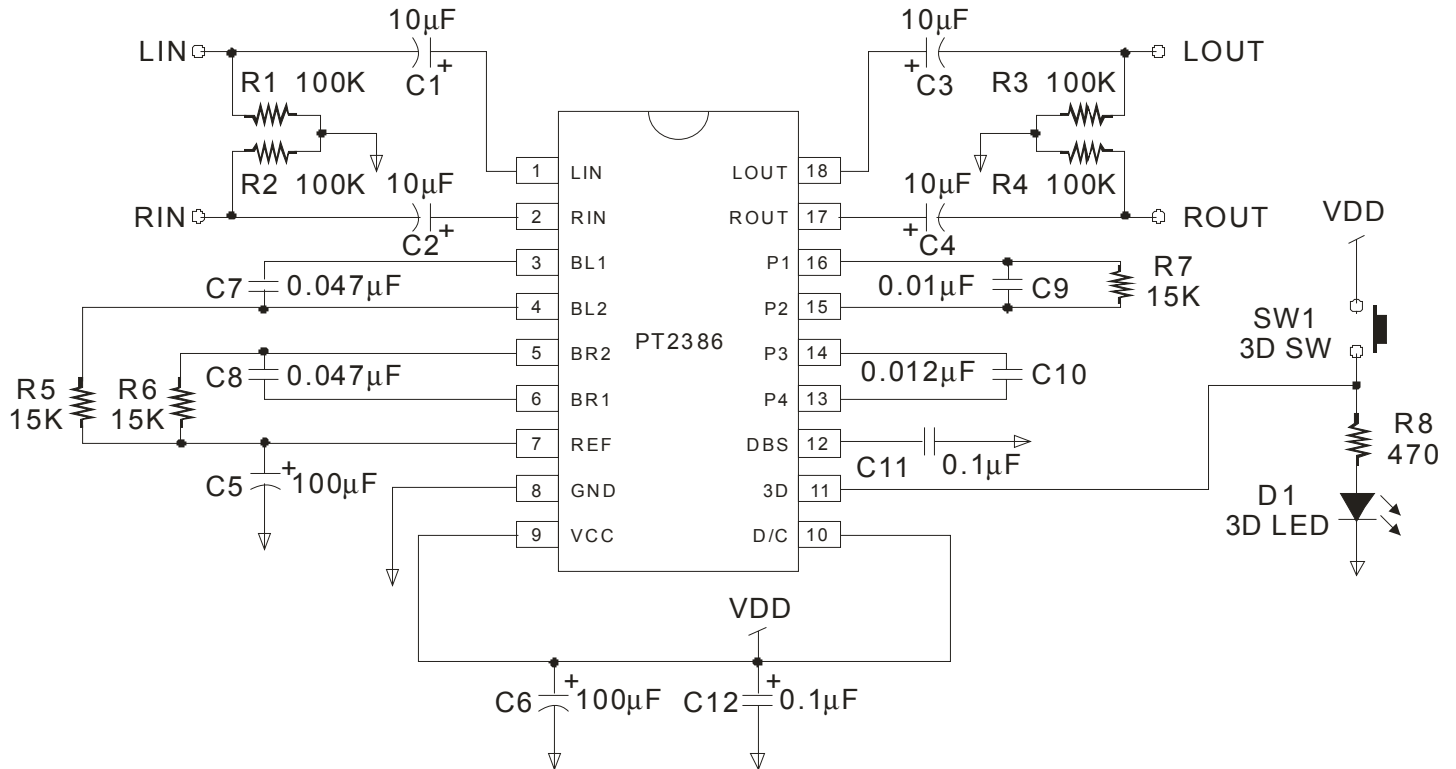



DIRECT MODE WITH 3D EFFECT & BASS BOOSTER FUNCTION

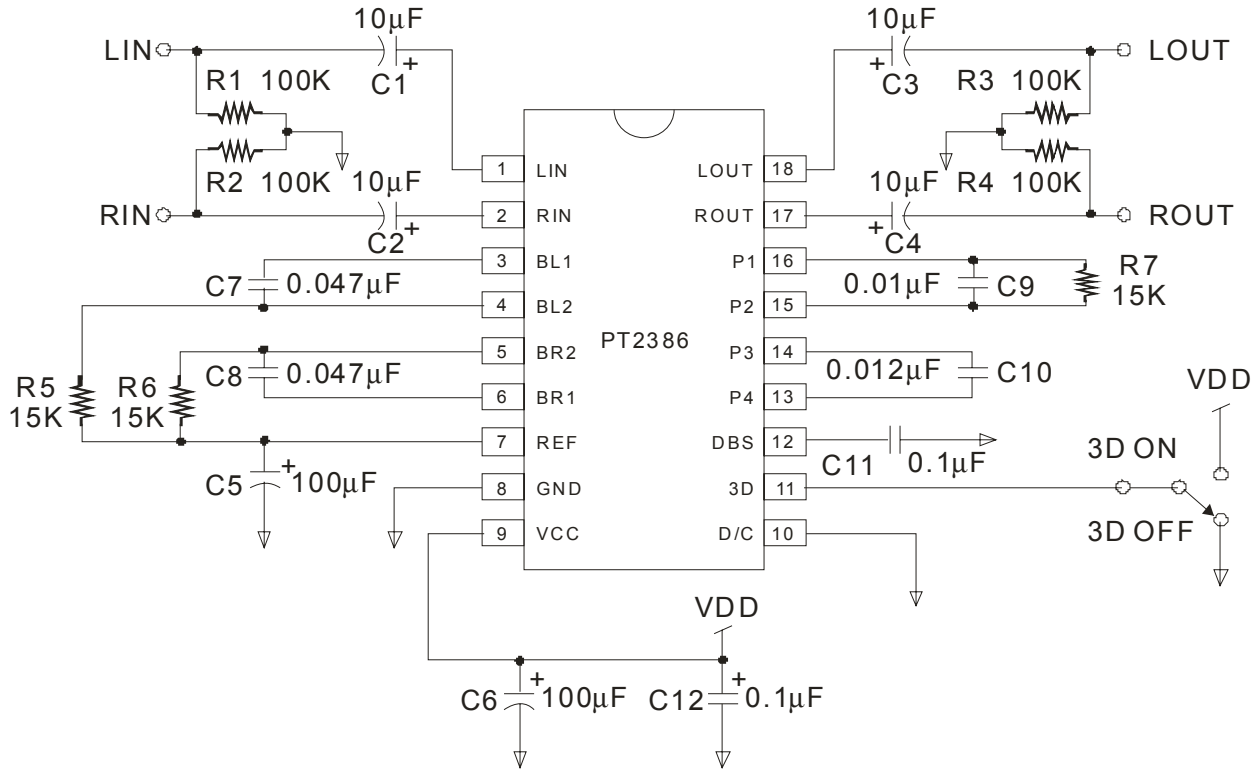



ORDER INFORMATION

Valid part Number	Package Type	Top Code
PT2386	18 Pins, DIP, 300mil	PT2386
PT2386-S	18 Pins, SOP, 300mil	PT2386-S



PACKAGE INFORMATION

18 PINS, DIP, 300MIL

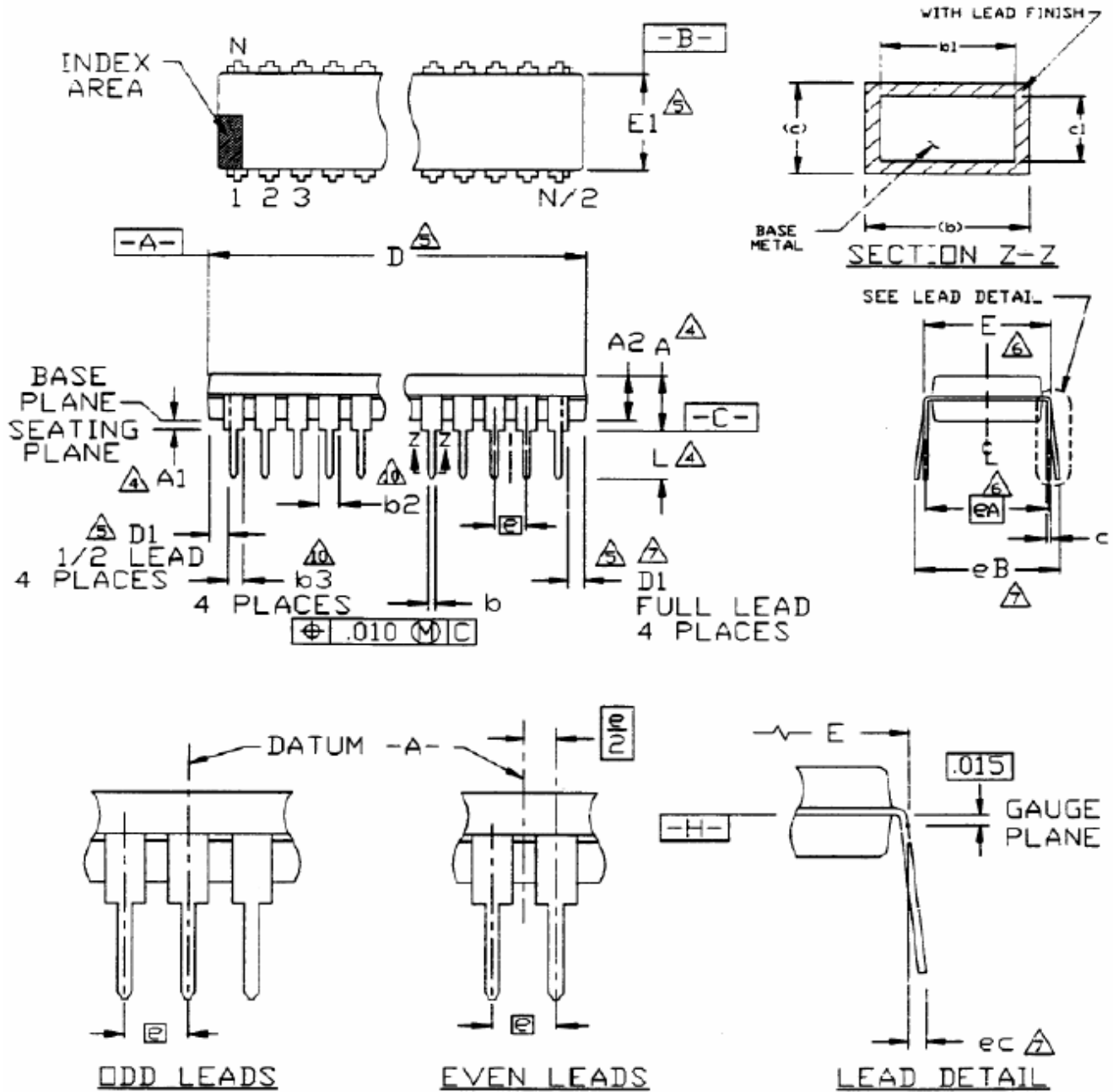



Symbol	Min.	Nom.	Max.
A			0.21
A1	0.15		
A2	0.115	0.13	0.195
b	0.014	0.018	0.022
b2	0.045	0.06	0.07
b3	0.03	0.039	0.045
c	0.008	0.01	0.014
D	0.88	0.90	0.92
D1	0.005		
E	0.30	0.31	0.325
E1	0.24	0.25	0.28
e	0.1 BSC.		
eA	0.3 BSC.		
eB			0.43
eC	0.00		0.60
L	0.115	0.13	0.15

Notes:

- All dimensioning are in INCHES.
 - Dimensioning and tolerancing per ANSI Y14.5M-1982.
 - Dimension "A", "A1" and "L" are measured with package seated in JEDEC Seating Plane Gauge GS-3.
 - "D", "D1" and "E1" dimensions do not include mold flash or protrusions. Mold flash or protrusions shall not exceed 0.010 inch.
 - "E" and "eA" measured with the leads constrained to be perpendicular to datum \square -C.
 - "eB" and "eC" are measured at the lead tips with the leads unconstrained.
 - "N" is the number of terminal position (N=18).
 - Pointed or rounded lead tips are preferred to ease insertion.
 - "b2" and "b3" maximum dimensions are not include dambar protrusions. Dambar protrusions shall not exceed 0.010 inch (0.25mm)
 - Distance between leads including Dambar protrusions to be 0.005 inch minimum.
 - Datum plane \square -H coincident with the bottom of lead, where lead exits body.
 - Refer to JEDEC MS-001, Variation AC
- JEDEC is the trademark of JEDEC SOLID STATE TECHNOLOGY ASSOCIATION.



18 PINS, SOP, 300MIL

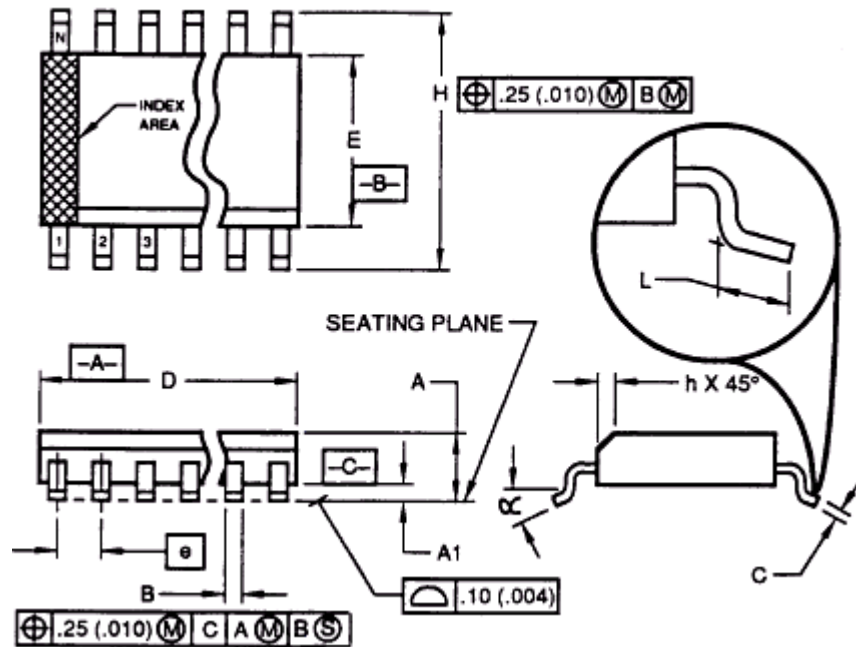

Symbol	Min.	Nom.	Max.
A	2.35		2.65
A1	0.10		0.30
B	0.33		0.51
C	0.23		0.32
D	11.35		11.75
E	7.40		7.60
e	1.27 BSC.		
H	10.00		10.65
h	0.25		0.75
L	0.40		1.27
∞	0°		8°



Notes:

1. Dimensioning and tolerancing per ANSI Y14.5-1982.
2. Dimension "D" does not include mold flash, protrusions or gate burrs. Mold flash protrusion or gate burrs shall not exceed 0.15mm (0.006 in) per side.
3. Dimension "E" does not include interlead flash or protrusions. Interlead flash or protrusions shall not exceed 0.25mm (0.010 in) per side.
4. The chamfer on the body is optional. If it is not present, a visual index feature must be located within the crosshatched area.
5. "L" is the length of the terminal for soldering to substrate.
6. "N" is the number of terminal positions. (N=18)
7. The lead width "B" as measured 0.36mm (0.014 in) or greater above the seating plane, shall not exceed a maximum value of 0.61mm (0.24 in)
8. Controlling dimension: MILLIMETER.
9. Refer to JEDEC MS-013 Variation AB.

JEDEC is the trademark of JEDEC SOLID STATE TECHNOLOGY ASSOCIATION.