

SI-8000E Series

Full-Mold, Separate Excitation Step-down Switching Mode Regulator ICs

■ Features

- Compact full-mold package (equivalent to TO220)
- High efficiency: 80%
- Requires only 4 discrete components
- Internally-adjusted phase correction and output voltage
- Built-in reference oscillator (60kHz)
- Built-in overcurrent and thermal protection circuits

■ Applications

- Power supplies for telecommunication equipment
- Onboard local power supplies

■ Lineup

Part Number	SI-8050E
V _o (V)	5.0
I _o (A)	0.6

■ Absolute Maximum Ratings

Parameter	Symbol	Ratings	Unit
DC Input Voltage	V _{IN}	43	V
Power Dissipation	P _{D1}	14(With infinite heatsink)	W
	P _{D2}	1.5(Without heatsink, stand-alone operation)	W
Junction Temperature	T _J	+125	°C
Storage Temperature	T _{stg}	-40 to +125	°C
Thermal Resistance(junction to case)	θ _{J-c}	7.0	°C/W
Thermal Resistance(junction to ambient air)	θ _{J-a}	66.7	°C/W

■ Recommended Operating Conditions

Parameter	Symbol	Ratings		Unit
		SI-8050E		
DC Input Voltage Range	V _{IN}	7 to 40		V
Output Current Range	I _o	0 to 0.6		A
Operating Junction Temperature Range	T _{jop}	-30 to +125		°C
Operating Temperature Range	T _{op}	-30 to +125		°C

■ Electrical Characteristics

(T_a=25°C)

Parameter	Symbol	Ratings			Unit
		SI-8050E			
		min.	typ.	max.	
Output Voltage	V _o	4.80	5.00	5.20	V
	Conditions	V _{IN} =20V, I _o =0.3A			
Efficiency	η		80		%
	Conditions	V _{IN} =20V, I _o =0.3A			
Oscillation Frequency	f		60		kHz
	Conditions	V _{IN} =20V, I _o =0.3A			
Line Regulation	ΔV _{OLINE}		80	100	mV
	Conditions	V _{IN} =10 to 30V, I _o =0.3A			
Load Regulation	ΔV _{OLOAD}		30	40	mV
	Conditions	V _{IN} =20V, I _o =0.1 to 0.4A			
Temperature Coefficient of Output Voltage	ΔV _o /ΔT _a		±0.5		mV/°C
Overcurrent Protection Starting Current	I _{S1}	0.61			A
	Conditions	V _{IN} =10V			

External Dimensions (TO220F-5)

(Unit : mm)

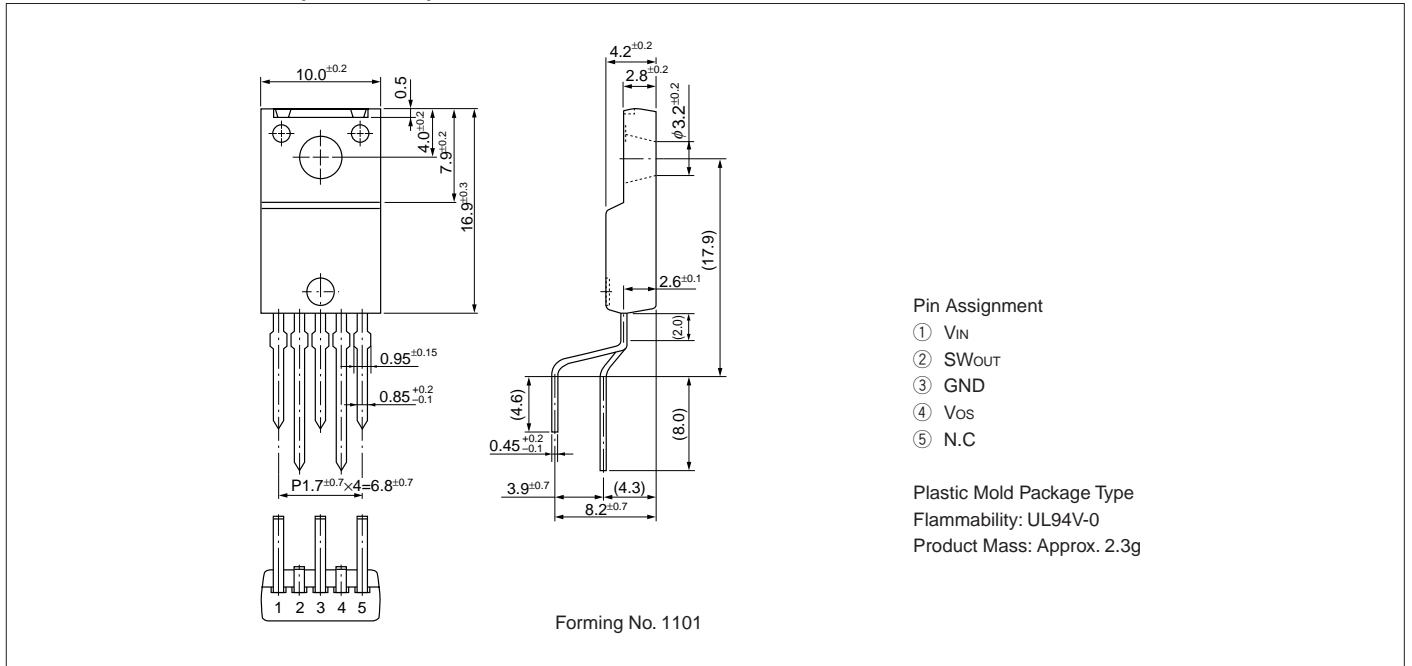

Block Diagram

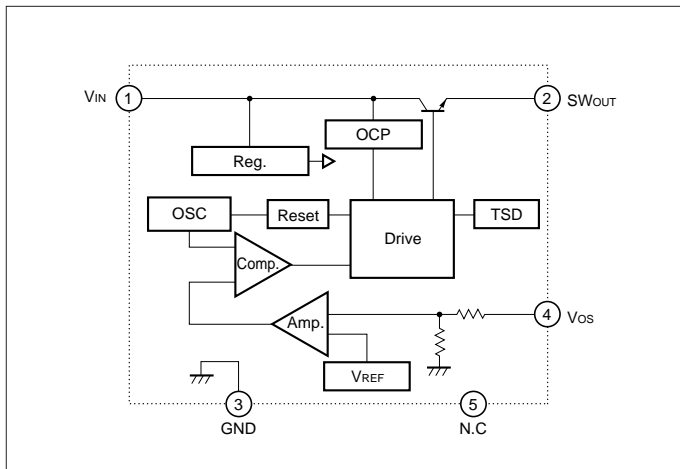

Typical Connection Diagram

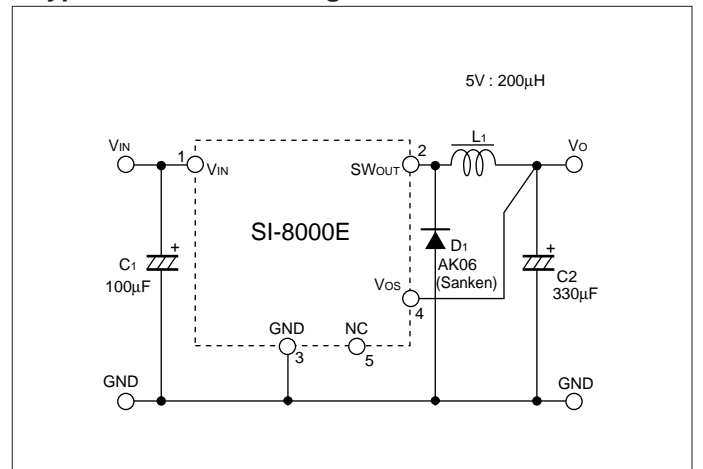

Ta-Pd Characteristics

