

# Customer Information Sheet

DRAWING No.: M80-19500XX

SHEET 2 OF 2

IF IN DOUBT - ASK

(C)

NOT TO SCALE

THIRD ANGLE PROJECTION

ALL DIMENSIONS IN mm

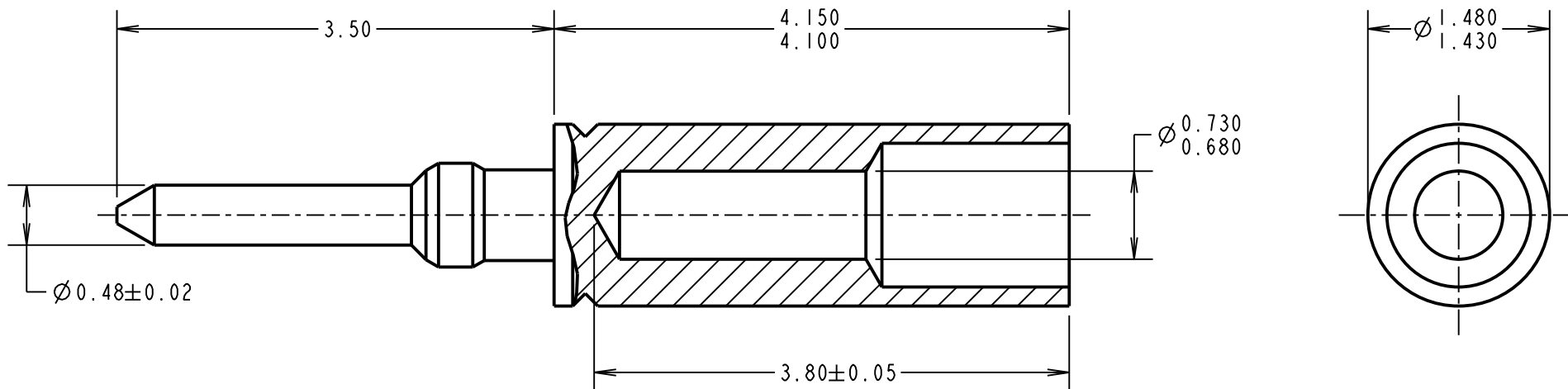

**SPECIFICATION:**

**MATERIAL:**

CONTACT SHELL = BRASS

**FINISH:**

05 = 0.25 - 0.30µ GOLD

06 = 3.5 - 5.0µ 100% TIN

OVER 1.0 - 2.0µ NICKEL

**MECHANICAL:**

DURABILITY = 500 OPERATIONS

**ENVIRONMENTAL:**

OPERATING TEMPERATURE = -55°C TO +125°C

**PACKING:**

BULK

FOR COMPLETE CONNECTOR SPECIFICATION, SEE COMPONENT SPECIFICATION C005XX (LATEST ISSUE)

**NOTES:**

- SUITABLE FOR WIRE GAUGE 24-28 AWG. MAXIMUM INSULATION DIAMETER Ø1.10mm, BS 3G 210 TYPE A WIRE RECOMMENDED. STRIP WIRE BY 2.00mm FOR CRIMPING.
- RECOMMENDED CRIMP TOOL = M22520/2-01, POSITIONER = Z80-193
- FOR INSTRUCTIONS ON HAND CRIMP TOOL M22520/2-01, SEE INSTRUCTION SHEET IS-01.
- SUITABLE FOR USE IN MALE CRIMP JACKSCREW DATAMATE MOULDINGS.

ORDER CODE:

**M80-19500XX**

FINISH

06 - 3.5-5.0µ 100% TIN OVER  
1.0-2.0µ NICKEL  
05 - 0.25-0.30µ GOLD

RA	2	03.08.10	10893
NAME	ISS.	DATE	C/NOTE
APPROVED:		R. ADDE	
CHECKED:		M. G. PLESTED	
DRAWN:		W. J. BOURNE	
CUSTOMER REF.:			
ASSEMBLY DRG:			

**HARWIN**

THIS DRAWING AND ANY INFORMATION OR DESCRIPTIVE MATTER SET OUT HEREON ARE CONFIDENTIAL AND COPYRIGHT PROPERTY OF THE HARWIN GROUP AND MUST NOT BE DISCLOSED, LOANED, COPIED OR USED FOR MANUFACTURING, TENDERING OR FOR ANY OTHER PURPOSE WITHOUT THEIR WRITTEN PERMISSION.

**TOLERANCES**

X. = ±1mm  
X.X = ±0.25mm  
X.XX = ±0.10mm  
X.XXX = ±0.01mm

ANGLES = ±5°  
UNLESS STATED

**MATERIAL:**

BRASS

FINISH: SEE ORDER CODE

S/AREA: mm<sup>2</sup>

**TITLE:**

JACKSCREW DATAMATE  
MALE CRIMP CONTACT  
(SMALL BORE)

**DRAWING NUMBER:**

**M80-19500XX**

HARWIN USA  
TEL: 603 893 5376  
FAX: 603 893 5396  
mis@harwin.com

HARWIN Europe (UK)  
TEL: 023 9231 4545  
FAX: 023 9231 4590  
mis@harwin.co.uk

HARWIN Asia  
TEL: +65 6 779 4909  
FAX: +65 6 779 3868  
mis@harwin.com.sg

SHT  
2  
OF 2