

# DATA SHEET

## **RM6S/I**

**RM, RM/I, RM/ILP cores and accessories**

Supersedes data of September 2004

2008 Sep 01



**FERROXCUBE**  
A YAGEO COMPANY

**CORE SETS**

**Effective core parameters**

SYMBOL	PARAMETER	VALUE	UNIT
$\Sigma(l/A)$	core factor (C1)	0.784	mm <sup>-1</sup>
$V_e$	effective volume	1090	mm <sup>3</sup>
$l_e$	effective length	29.2	mm
$A_e$	effective area	37.0	mm <sup>2</sup>
$A_{min}$	minimum area	31.2	mm <sup>2</sup>
m	mass of set	≈ 5.5	g

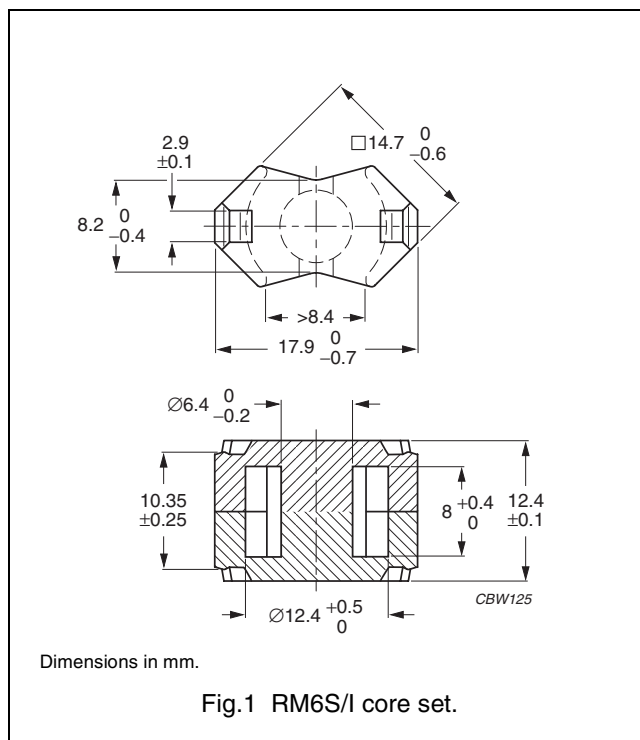

**Core sets for filter applications**

Clamping force for  $A_L$  measurements, 20 ±10 N.

GRADE	$A_L$ (nH)	$\mu_e$	AIR GAP (μm)	TYPE NUMBER
3B46 <small>des</small>	3650 ± 25 %	≈ 2280	≈ 0	RM6S/I-3B46
3D3	160 ±3%	≈ 100	≈ 300	RM6S/I-3D3-A160
	250 ±5%	≈ 156	≈ 170	RM6S/I-3D3-A250
	315 ±8%	≈ 197	≈ 120	RM6S/I-3D3-A315
	1050 ±25%	≈ 655	≈ 0	RM6S/I-3D3
3H3	315 ±3%	≈ 198	≈ 150	RM6S/I-3H3-A315
	400 ±3%	≈ 251	≈ 110	RM6S/I-3H3-A400
	630 ±5%	≈ 396	≈ 65	RM6S/I-3H3-A630
	2350 ±25%	≈ 1470	≈ 0	RM6S/I-3H3

**Core sets for general purpose transformers and power applications**

Clamping force for  $A_L$  measurements, 20 ±10 N.

GRADE	$A_L$ (nH)	$\mu_e$	TOTAL AIR GAP (μm)	TYPE NUMBER
3C81	63 ±3%	≈ 40	≈ 1080	RM6S/I-3C81-E63
	100 ±3%	≈ 63	≈ 600	RM6S/I-3C81-A100
	160 ±3%	≈ 100	≈ 340	RM6S/I-3C81-A160
	250 ±3%	≈ 157	≈ 200	RM6S/I-3C81-A250
	315 ±3%	≈ 198	≈ 150	RM6S/I-3C81-A315
	3000 ±25%	≈ 1870	≈ 0	RM6S/I-3C81

## RM, RM/I, RM/ILP cores and accessories

## RM6S/I

GRADE	$A_L$ (nH)	$\mu_e$	TOTAL AIR GAP ( $\mu\text{m}$ )	TYPE NUMBER
3C90	63 $\pm 3\%$	$\approx 40$	$\approx 1080$	RM6S/I-3C90-A63
	100 $\pm 3\%$	$\approx 63$	$\approx 600$	RM6S/I-3C90-A100
	160 $\pm 3\%$	$\approx 100$	$\approx 340$	RM6S/I-3C90-A160
	250 $\pm 3\%$	$\approx 157$	$\approx 200$	RM6S/I-3C90-A250
	315 $\pm 3\%$	$\approx 198$	$\approx 150$	RM6S/I-3C90-A315
	400 $\pm 3\%$	$\approx 251$	$\approx 110$	RM6S/I-3C90-A400
	630 $\pm 5\%$	$\approx 396$	$\approx 65$	RM6S/I-3C90-A630
2600 $\pm 25\%$	$\approx 1630$	$\approx 0$	RM6S/I-3C90	
3C91 <b>des</b>	3000 $\pm 25\%$	$\approx 1880$	$\approx 0$	RM6S/I-3C91
3C94	63 $\pm 3\%$	$\approx 40$	$\approx 1080$	RM6S/I-3C94-A63
	100 $\pm 3\%$	$\approx 63$	$\approx 600$	RM6S/I-3C94-A100
	160 $\pm 3\%$	$\approx 100$	$\approx 340$	RM6S/I-3C94-A160
	250 $\pm 3\%$	$\approx 157$	$\approx 200$	RM6S/I-3C94-A250
	315 $\pm 3\%$	$\approx 198$	$\approx 150$	RM6S/I-3C94-A315
	400 $\pm 3\%$	$\approx 251$	$\approx 110$	RM6S/I-3C94-A400
	630 $\pm 5\%$	$\approx 396$	$\approx 65$	RM6S/I-3C94-A630
2600 $\pm 25\%$	$\approx 1630$	$\approx 0$	RM6S/I-3C94	
3C95 <b>des</b>	3000 $\pm 25\%$	$\approx 1880$	$\approx 0$	RM6S/I-3C95
3C96 <b>des</b>	2350 $\pm 25\%$	$\approx 1470$	$\approx 0$	RM6S/I-3C96
3F3	63 $\pm 3\%$	$\approx 40$	$\approx 1080$	RM6S/I-3F3-A63
	100 $\pm 3\%$	$\approx 63$	$\approx 600$	RM6S/I-3F3-A100
	160 $\pm 3\%$	$\approx 100$	$\approx 340$	RM6S/I-3F3-A160
	250 $\pm 3\%$	$\approx 157$	$\approx 200$	RM6S/I-3F3-A250
	315 $\pm 3\%$	$\approx 198$	$\approx 150$	RM6S/I-3F3-A315
	2150 $\pm 25\%$	$\approx 1350$	$\approx 0$	RM6S/I-3F3
3F35 <b>prot</b>	1750 $\pm 25\%$	$\approx 1100$	$\approx 0$	RM6S/I-3F35
3F4 <b>des</b>	63 $\pm 3\%$	$\approx 39$	$\approx 1040$	RM6S/I-3F4-A63
	100 $\pm 3\%$	$\approx 62$	$\approx 570$	RM6S/I-3F4-A100
	160 $\pm 3\%$	$\approx 100$	$\approx 310$	RM6S/I-3F4-A160
	250 $\pm 3\%$	$\approx 156$	$\approx 170$	RM6S/I-3F4-A250
	315 $\pm 3\%$	$\approx 197$	$\approx 130$	RM6S/I-3F4-A315
	1250 $\pm 25\%$	$\approx 780$	$\approx 0$	RM6S/I-3F4
3F45 <b>prot</b>	1250 $\pm 25\%$	$\approx 780$	$\approx 0$	RM6S/I-3F45

## RM, RM/I, RM/ILP cores and accessories

RM6S/I

**Core sets of high permeability grades**Clamping force for  $A_L$  measurements,  $20 \pm 10$  N.

GRADE	$A_L$ (nH)	$\mu_e$	TYPE NUMBER
3E27	6000 $\pm$ 25%	$\approx$ 3770	RM6S/I-3E27
3E5	8600 +40/-30%	$\approx$ 5400	RM6S/I-3E5
3E6	11000 +40/-30%	$\approx$ 6910	RM6S/I-3E6

**Properties of core sets under power conditions**

GRADE	B (mT) at	CORE LOSS (W) at				
	H = 250 A/m; f = 25 kHz; T = 100 °C	f = 25 kHz; $\hat{B}$ = 200 mT; T = 100 °C	f = 100 kHz; $\hat{B}$ = 100 mT; T = 100 °C	f = 100 kHz; $\hat{B}$ = 200 mT; T = 25 °C	f = 100 kHz; $\hat{B}$ = 200 mT; T = 100 °C	f = 400 kHz; $\hat{B}$ = 50 mT; T = 100 °C
3C81	$\geq$ 320	$\leq$ 0.25	–	–	–	–
3C90	$\geq$ 320	$\leq$ 0.13	$\leq$ 0.14	–	–	–
3C91	$\geq$ 315	–	$\leq$ 0.08 <sup>(1)</sup>	–	$\leq$ 0.4 <sup>(1)</sup>	–
3C94	$\geq$ 320	–	$\leq$ 0.11	–	$\leq$ 0.6	–
3C95	$\geq$ 320	–	–	$\leq$ 0.64	$\leq$ 0.61	–
3C96	$\geq$ 340	–	$\leq$ 0.08	–	$\leq$ 0.4	$\leq$ 0.2
3F3	$\geq$ 315	–	$\leq$ 0.14	–	–	$\leq$ 0.2
3F35	$\geq$ 315	–	–	–	–	$\leq$ 0.12
3F4	$\geq$ 250	–	–	–	–	–

**Properties of core sets under power conditions (continued)**

GRADE	B (mT) at	CORE LOSS (W) at				
	H = 250 A/m; f = 25 kHz; T = 100 °C	f = 500 kHz; $\hat{B}$ = 50 mT; T = 100 °C	f = 500 kHz; $\hat{B}$ = 100 mT; T = 100 °C	f = 1 MHz; $\hat{B}$ = 30 mT; T = 100 °C	f = 1 MHz; $\hat{B}$ = 50 mT; T = 100 °C	f = 3 MHz; $\hat{B}$ = 10 mT; T = 100 °C
3C96	$\geq$ 340	$\leq$ 0.5	–	–	–	–
3F3	$\geq$ 315	–	–	–	–	–
3F35	$\geq$ 315	$\leq$ 0.16	$\leq$ 1.3	–	–	–
3F4	$\geq$ 250	–	–	$\leq$ 0.33	–	$\leq$ 0.53
3F45	$\geq$ 250	–	–	$\leq$ 0.25	$\leq$ 0.94	$\leq$ 0.44

**Note**

1. Measured at 60 °C.

**COIL FORMERS**

**General data**

PARAMETER	DESCRIPTION
Coil former material	polybutyleneterephthalate (PBT), glass-reinforced, flame retardant in accordance with "UL 94V-0"; UL file number E45329(M)
Pin material	copper-tin alloy (CuSn), tin (Sn) plated
Maximum operating temperature	155 °C, "IEC 60085", class F
Resistance to soldering heat	"IEC 60068-2-20", Part 2, Test Tb, method 1B, 350 °C, 3.5 s
Solderability	"IEC 60068-2-20", Part 2, Test Ta, method 1

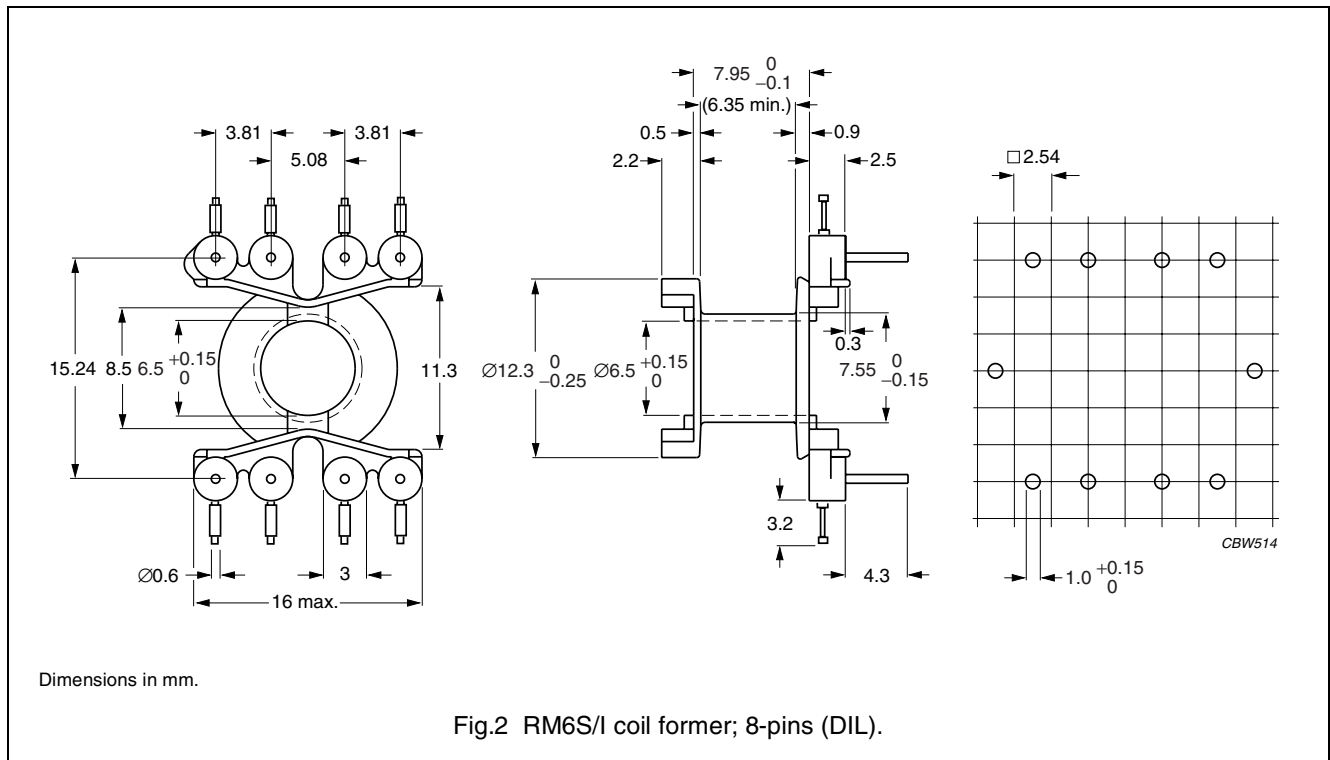

**Winding data and area product for 8-pins RM6S/I coil former (DIL)**

NUMBER OF SECTIONS	WINDING AREA (mm <sup>2</sup> )	WINDING WIDTH (mm)	AVERAGE LENGTH OF TURN (mm)	AREA PRODUCT Ae x Aw (mm <sup>4</sup> )	TYPE NUMBER
1	15.7	6.2	31	5.81	CPV-RM6S/I-1S-8PD

General data SMD coil former

PARAMETER	SPECIFICATION
Coil former material	phenolformaldehyde (PF), glass-reinforced, flame retardant in accordance with "UL 94V-0"; UL file number E41429 (M)
Solder pad material	copper-tin alloy (CuSn), tin (Sn) plated
Maximum operating temperature	155 °C, "IEC 60085", class F
Resistance to soldering heat	"IEC 60068-2-20", Part 2, Test Tb, method 1B, 350 °C, 3.5 s
Solderability	"IEC 60068-2-20", Part 2, Test Ta, method 1

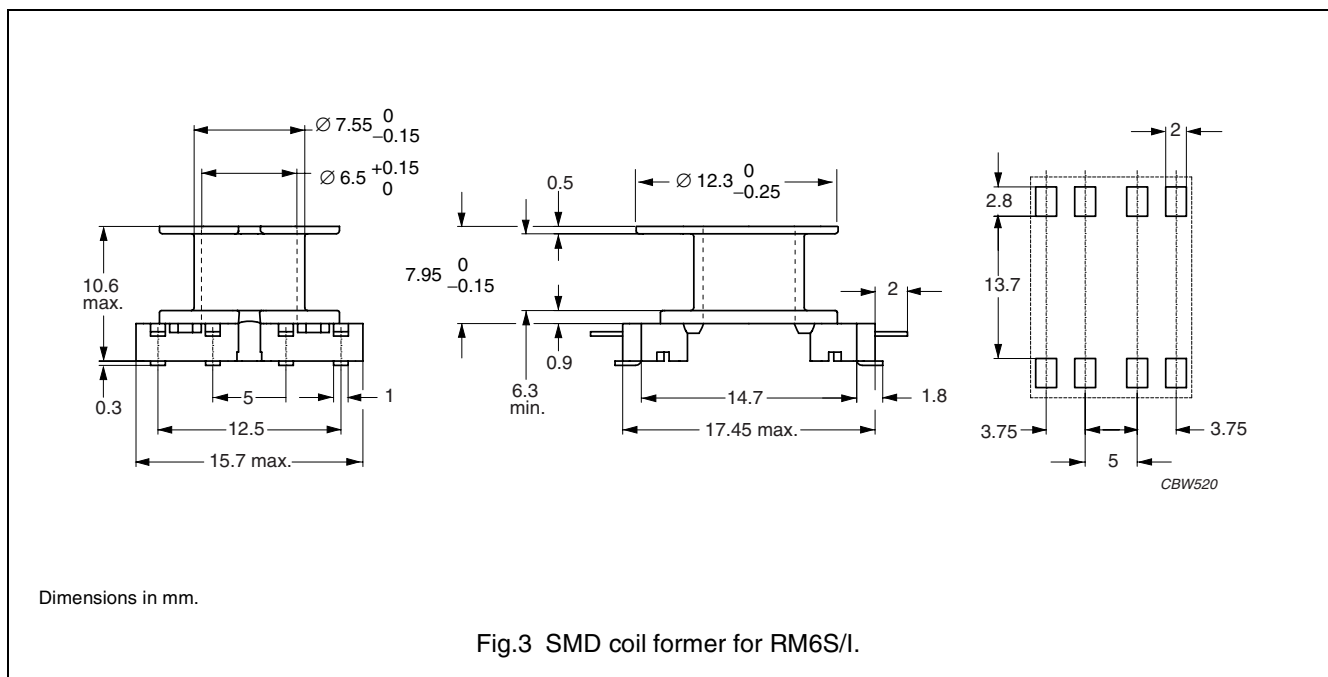

Winding data and area product for RM6S/I coil former (SMD)

NUMBER OF SECTIONS	NUMBER OF SOLDER PADS	WINDING AREA (mm <sup>2</sup> )	WINDING WIDTH (mm)	AVERAGE LENGTH OF TURN (mm)	AREA PRODUCT Ae x Aw (mm <sup>4</sup> )	TYPE NUMBER
1	8	14	6.3	31	518	CSV5-RM6S-1S-8P

General data SMD coil former

PARAMETER	SPECIFICATION
Coil former material	phenolformaldehyde (PF), glass-reinforced, flame retardant in accordance with "UL 94V-0"; UL file number E41429 (M)
Solder pad material	copper-tin alloy (CuSn), tin (Sn) plated
Maximum operating temperature	155 °C, "IEC 60085", class F
Resistance to soldering heat	"IEC 60068-2-20", Part 2, Test Tb, method 1B, 350 °C, 3.5 s
Solderability	"IEC 60068-2-20", Part 2, Test Ta, method 1

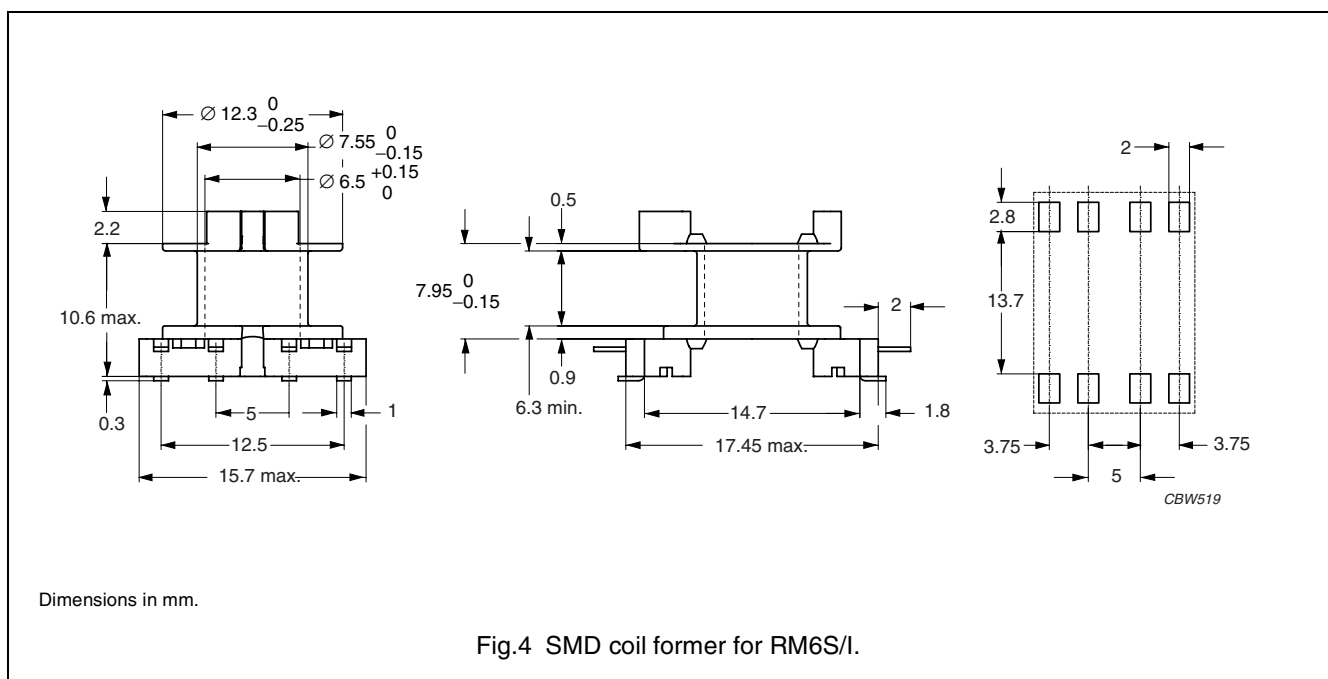

Winding data and area product for RM6S/I coil former (SMD)

NUMBER OF SECTIONS	NUMBER OF SOLDER PADS	WINDING AREA (mm <sup>2</sup> )	WINDING WIDTH (mm)	AVERAGE LENGTH OF TURN (mm)	AREA PRODUCT Ae x Aw (mm <sup>4</sup> )	TYPE NUMBER
1	8	14.2	6.3	31.4	525	CSVS-RM6S-1S-8P-B

## RM, RM/I, RM/ILP cores and accessories

## RM6S/I

Additional coil formers are those of "RM6S", but "area product" is different..

## Winding data and area product (for RM6S/I) for 4-pins RM6S coil former

NUMBER OF SECTIONS	NUMBER OF PINS	PIN POSITIONS USED	WINDING AREA (mm <sup>2</sup> )	WINDING WIDTH (mm)	AVERAGE LENGTH OF TURN (mm)	AREA PRODUCT Ae x Aw (mm <sup>4</sup> )	TYPE NUMBER
1	4	all	15	6.4	30	555	CSV-RM6S/R-1S-4P
2	4	all	2 × 7.0	2 × 3.0	30	2 x 259	CSV-RM6S/R-2S-4P

## Winding data and area product (for RM6S/I) for RM6S coil former

NUMBER OF SECTIONS	NUMBER OF PINS	PIN POSITIONS USED	WINDING AREA (mm <sup>2</sup> )	WINDING WIDTH (mm)	AVERAGE LENGTH OF TURN (mm)	AREA PRODUCT Ae x Aw (mm <sup>4</sup> )	TYPE NUMBER
1	6	all	15.0	6.3	30.0	555	CSV-RM6S-1S-6P-G <sup>(1)</sup>
1	5	1, 2, 3, 5, 6	15.0	6.3	30.0	555	CSV-RM6S-1S-5P-G <sup>(1)</sup>
1	4	2, 3, 5, 6	15.0	6.3	30.0	555	CSV-RM6S-1S-4P-G <sup>(1)</sup>
2	6	all	2 × 7.0	2 × 3	30.0	2 x 259	CSV-RM6S-2S-6P-G <sup>(1)</sup>

**Note 1**

Also available with post-inserted pins.

## Winding data and area product (for RM6S/I) for RM6S coil former

NUMBER OF SECTIONS	NUMBER OF PINS	WINDING AREA (mm <sup>2</sup> )	WINDING WIDTH (mm)	AVERAGE LENGTH OF TURN (mm)	AREA PRODUCT Ae x Aw (mm <sup>4</sup> )	TYPE NUMBER
1	8	14.5	6.26	30.7	536	CSV-RM6S-1S-8P



**MOUNTING PARTS**

**General data**

ITEM	SPECIFICATION
Clamping force	≈10 N
Clip material	stainless steel (CrNi)
Clip plating	tin (Sn)
Solderability	"IEC 60068-2-20", Part 2, Test Ta, method 1
Type number	CLI/P-RM6/I

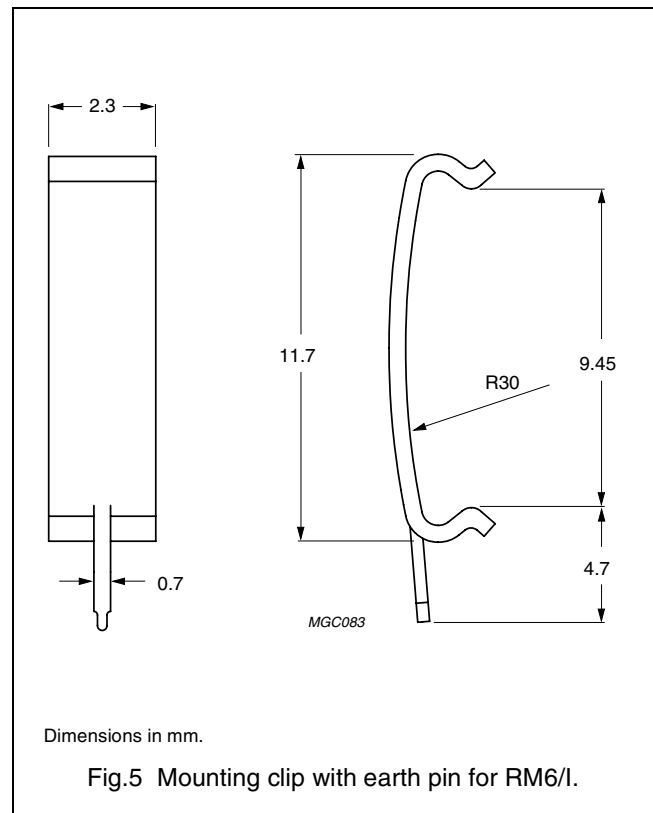

**General data mounting clip without earth pin**

ITEM	SPECIFICATION
Clamping force	≈10 N
Clip material	stainless steel (CrNi)
Type number	CLI-RM6/I

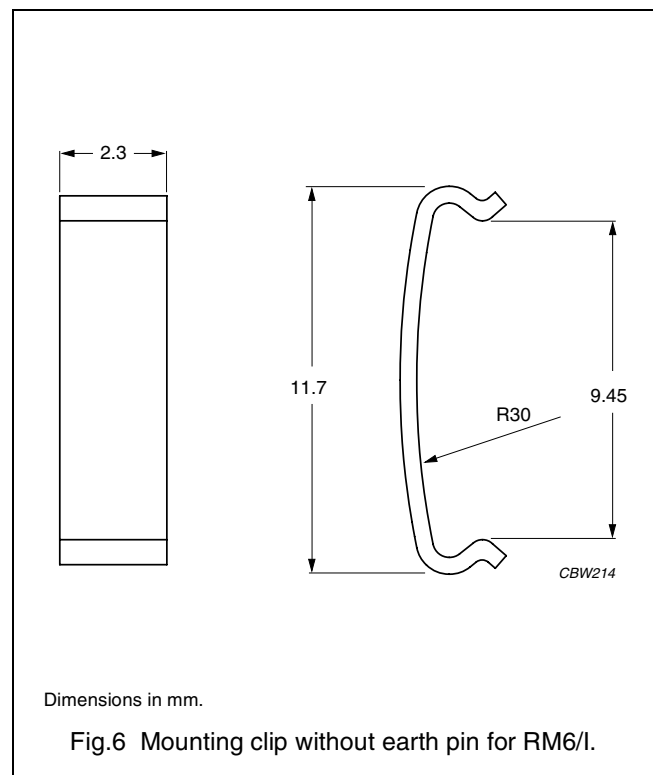



**DATA SHEET STATUS DEFINITIONS**

DATA SHEET STATUS	PRODUCT STATUS	DEFINITIONS
Preliminary specification	Development	This data sheet contains preliminary data. Ferroxcube reserves the right to make changes at any time without notice in order to improve design and supply the best possible product.
Product specification	Production	This data sheet contains final specifications. Ferroxcube reserves the right to make changes at any time without notice in order to improve design and supply the best possible product.

**DISCLAIMER**

**Life support applications** — These products are not designed for use in life support appliances, devices, or systems where malfunction of these products can reasonably be expected to result in personal injury. Ferroxcube customers using or selling these products for use in such applications do so at their own risk and agree to fully indemnify Ferroxcube for any damages resulting from such application.

**PRODUCT STATUS DEFINITIONS**

STATUS	INDICATION	DEFINITION
<b>Prototype</b>		These are products that have been made as development samples for the purposes of technical evaluation only. The data for these types is provisional and is subject to change.
<b>Design-in</b>		These products are recommended for new designs.
<b>Preferred</b>		These products are recommended for use in current designs and are available via our sales channels.
<b>Support</b>		These products are <b>not</b> recommended for new designs and may not be available through all of our sales channels. Customers are advised to check for availability.