

MM1Z2V0B - MM1Z39B

ZENER DIODES

V_Z : 2.0 to 39 V

P_D : 500 mW

FEATURES :

- * Total Power Dissipation 500 mW
- * Small Plastic Package suitable for surface mounted design
- * Tolerance approximately $\pm 2\%$
- * Wide Zener Reverse Voltage Range 2.0 V to 39 V
- * Pb / RoHS Free

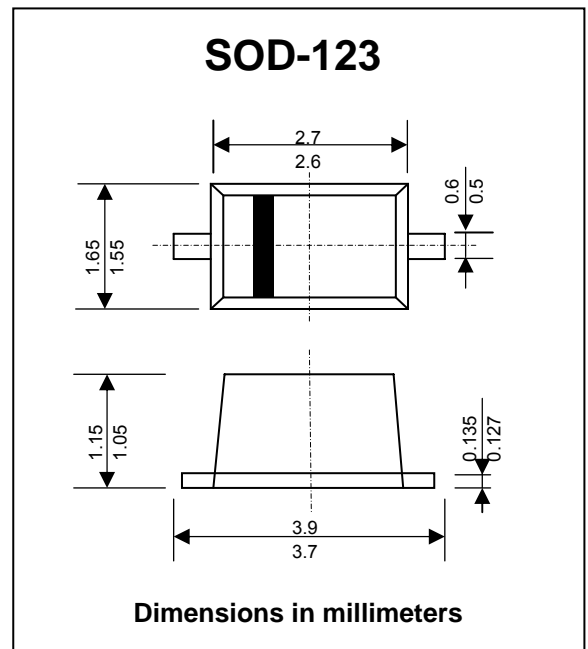

MECHANICAL DATA :

- * Case : SOD-123
- * Weight : 0.01 gram (approximately)

Maximum Ratings and Thermal Characteristics

Rating at 25 °C ambient temperature unless otherwise specified.

Parameter	Symbol	Value	Unit
Total Power Dissipation	P_{tot}	500	mW
Maximum Forward Voltage at $I_F = 10$ mA	V_F	0.9	V
Thermal Resistance Junction to Ambient Air	$R_{\theta JA}$	0.3	K/mW
Junction Temperature Range	T_J	150	°C
Storage Temperature Range	T_{STG}	-55 to + 150	°C

ELECTRICAL CHARACTERISTICS

TYPE NO.	Marking	Zener Voltage ⁽¹⁾			Test Current	Dynamic Impedance ⁽²⁾		Max. Reverse Leakage Current		Temp. Coefficient of Zener Voltage	
		V _Z @ I _{ZT} (V)				I _{ZT} (mA)	Z _{ZT} @ I _{ZT}	I _R @ V _R		TK _{VZ} (%/K)	
		Min.	Nom.	Max.	(Ω)		(mA)	(μA)	(V)	Min.	Max.
MM1Z2V0B	9A	1.85	2.0	2.20	5	100	5	120	0.5	-0.09	-0.06
MM1Z2V2B	9B	2.10	2.2	2.40	5	100	5	120	0.7	-0.09	-0.06
MM1Z2V4B	9C	2.30	2.4	2.65	5	100	5	120	1.0	-0.09	-0.06
MM1Z2V7B	9D	2.65	2.7	2.95	5	110	5	120	1.0	-0.09	-0.06
MM1Z3V0B	9E	2.95	3.0	3.25	5	120	5	50	1.0	-0.08	-0.05
MM1Z3V3B	9F	3.25	3.3	3.55	5	130	5	20	1.0	-0.08	-0.05
MM1Z3V6B	9H	3.60	3.6	3.845	5	130	5	10	1.0	-0.08	-0.05
MM1Z3V9B	9J	3.89	3.9	4.16	5	130	5	5	1.0	-0.08	-0.05
MM1Z4V3B	9K	4.17	4.3	4.43	5	130	5	5	1.0	-0.06	-0.03
MM1Z4V7B	9M	4.55	4.7	4.80	5	130	5	2	1.0	-0.05	+0.02
MM1Z5V1B	9N	4.95	5.1	5.20	5	130	5	2	1.5	-0.02	+0.02
MM1Z5V6B	9P	5.45	5.6	5.73	5	80	5	1	2.5	-0.05	+0.05
MM1Z6V2B	9R	6.00	6.2	6.33	5	50	5	1	3.0	0.03	0.06
MM1Z6V8B	9X	6.65	6.8	7.00	5	30	5	0.5	3.5	0.03	0.07
MM1Z7V5B	9Y	7.28	7.5	7.70	5	30	5	0.5	4.0	0.03	0.07
MM1Z8V2B	9Z	8.02	8.2	8.45	5	30	5	0.5	5.0	0.03	0.08
MM1Z9V1B	0A	8.80	9.1	9.30	5	30	5	0.5	6.0	0.03	0.09
MM1Z10B	0B	9.75	10	10.30	5	30	5	0.1	7.0	0.03	0.10
MM1Z11B	0C	10.70	11	11.28	5	30	5	0.1	8.0	0.03	0.11
MM1Z12B	0D	11.70	12	12.30	5	35	5	0.1	9.0	0.03	0.11
MM1Z13B	0E	12.43	13	14.00	5	35	5	0.1	10	0.03	0.11
MM1Z15B	0F	13.80	15	15.56	5	40	5	0.1	11	0.03	0.11
MM1Z16B	0H	15.31	16	17.14	5	40	5	0.1	12	0.03	0.11
MM1Z18B	0J	16.89	18	19.08	5	45	5	0.1	13	0.03	0.11
MM1Z20B	0K	18.80	20	21.14	5	50	5	0.1	15	0.03	0.11
MM1Z22B	0M	20.81	22	23.25	5	55	5	0.1	17	0.04	0.12
MM1Z24B	0N	22.86	24	25.66	5	60	5	0.1	19	0.04	0.12
MM1Z27B	0P	25.10	27	28.90	5	70	2	0.1	21	0.04	0.12
MM1Z30B	0R	28.00	30	32.00	5	80	2	0.1	23	0.04	0.12
MM1Z33B	0X	31.00	33	35.00	5	80	2	0.1	25	0.04	0.12
MM1Z36B	0Y	34.00	36	38.00	5	90	2	0.1	27	0.04	0.12
MM1Z39B	0Z	37.00	39	41.00	5	100	2	2.0	30	0.04	0.12

Notes :

- (1) V_Z is tested with pulses (20ms).
- (2) V_Z is measured at I_Z by given a very small A.C. current signal.