



Key Modules For Your Success

CSR BLUETOOTH MODULES

MB-C041



Specification

Version 1.0

28-July-06

Product No.: MB-C041

Product Description: Class 1 BT SPP Module

Issue Date: 2006/7/28

Release Version: 1.0

Contents

1. Hardware & Technical Information.....	3
1.1 Pin definition	3
1.2 Mechanical Specification.....	4
1.3 Block Diagram.....	5
1.4 Electrical Characteristics	6
1.5 Radio Characteristics	7
1.6 Reference Schematics.....	8
2. Software / Profile	9
3. Packing & Label Information	9
3.1 Label Information	10
3.2 Packaging.....	11
4. Standard Setup Information	12
5. Customization Information	12

1. Hardware & Technical Information

1.1 Pin definition

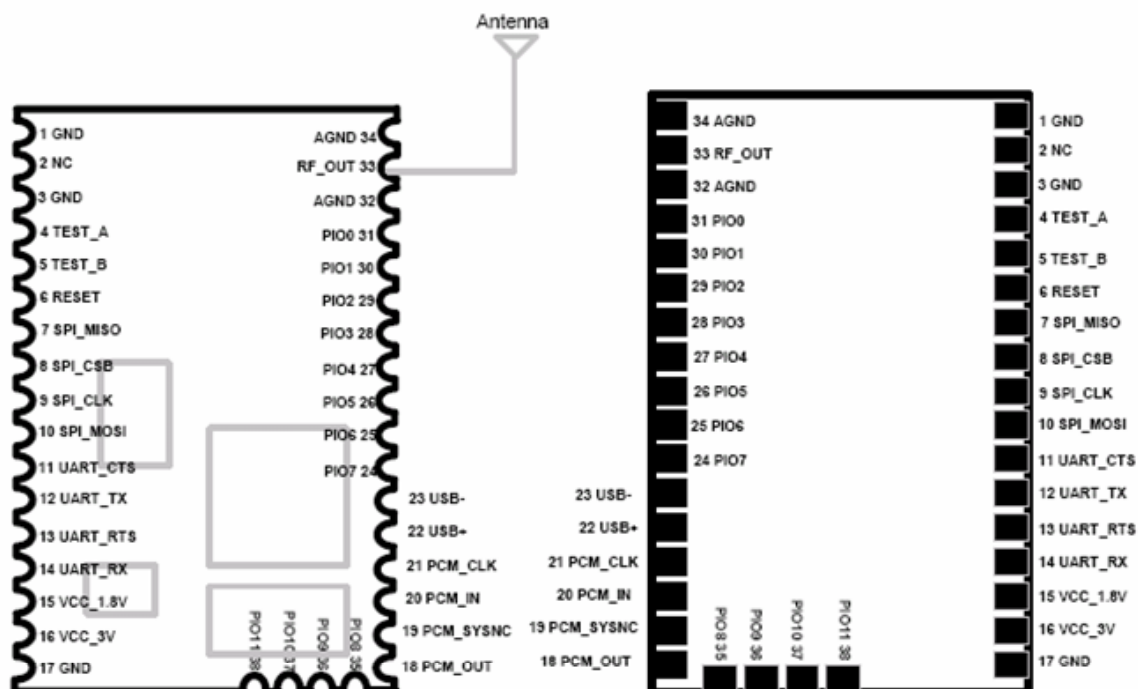

Pin No.	Name	Type	Note	Pin No.	Name	Type	Note
1	Ground			34	Ground		
2	NC			33	RF_OUT	Out	
3	Ground			32	Ground		
4	TestA		Internal testing using	31	PIO0	In/Out	
5	TestB		Internal testing using	30	PIO1	In/Out	
6	Reset	Input		29	PIO2	In/Out	
7	SPI_MISO		Internal testing using	28	PIO3	In/Out	
8	SPI_CSB		Internal testing using	27	PIO4	In/Out	
9	SPI_CLK		Internal testing using	26	PIO5	In/Out	
10	SPI_MOSI		Internal testing using	25	PIO6	In/Out	
11	UART_CTS	Input		24	PIO7	Out	Driving LED
12	UART_TX	Out		23	USB-	In/Out	
13	UART_RTS	Out		22	USB+	In/Out	
14	UART_RX	Input		21	PCM_CLK	In/Out	
15	VCC_1.8V	Out		20	PCM_IN	In	
16	VCC_3.3V	Input		19	PCM_SYNC	In/Out	
17	Ground			18	PCM_OUT	Out	

Pin No.	Name	Type	Note	Pin No.	Name	Type	Note
35	PIO8	In/Out		37	PIO10	In/Out	
36	PIO9	In/Out		38	PIO11	In/Out	

1.2 Mechanical Specification

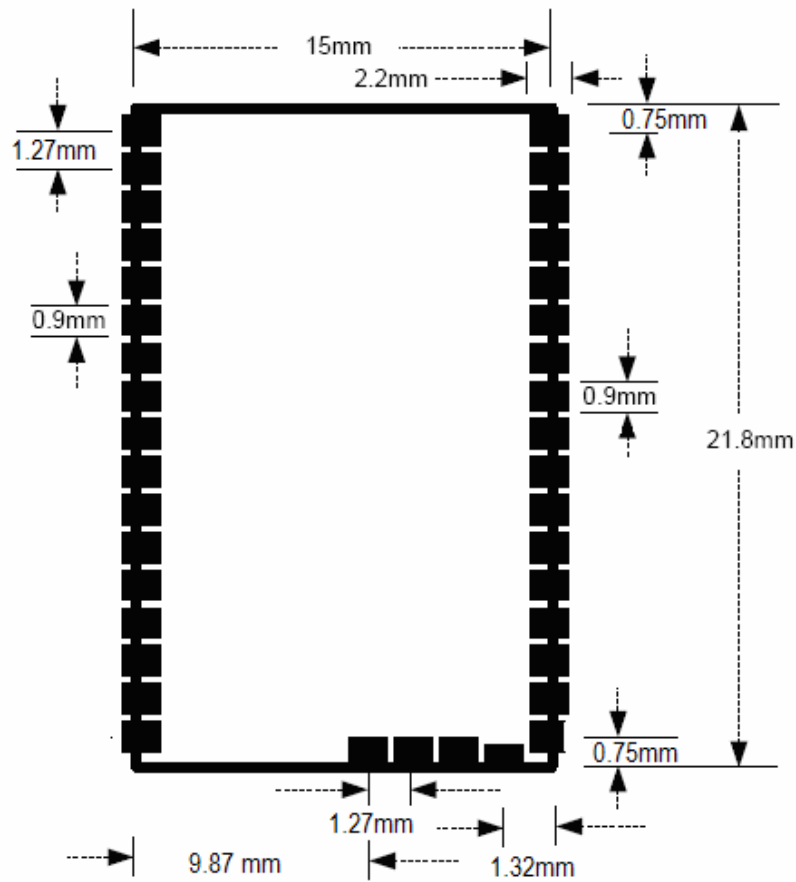

Fig. 1.2.1 Mechanical Specification

1.3 Block Diagram

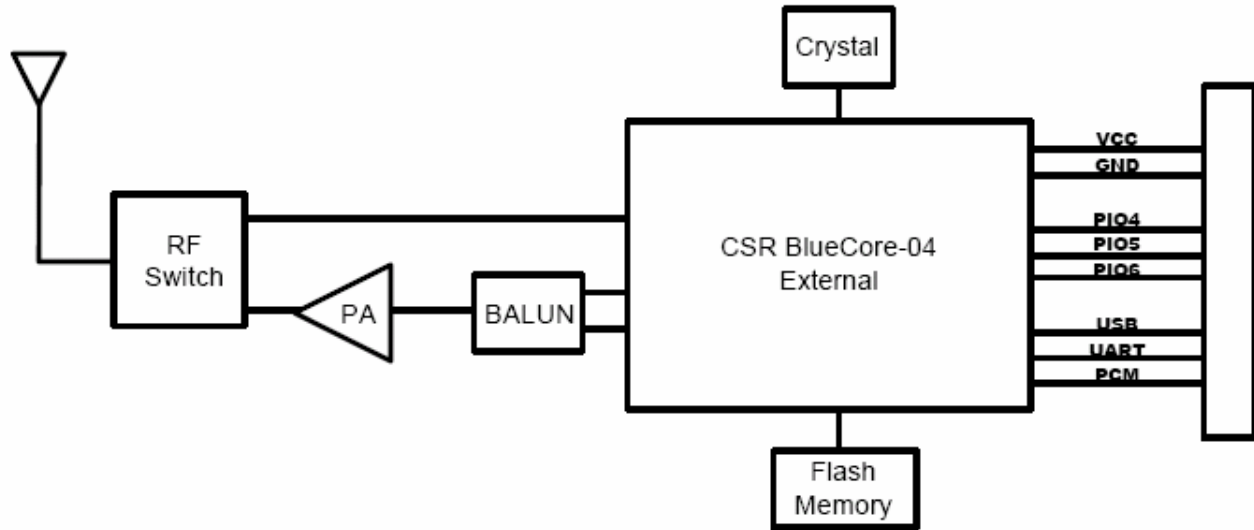

Fig 1.3.1 MB-C041 Class1 BT2.0 Module Block Diagram

1.4 Electrical Characteristics MB-C041 / Class1

	Min	Typ.	Max.	Unit
Supply Voltage	3.0	3.3	3.6	V
RX Supply Current	-	60	-	mA
TX Supply Current(Normal)	-	65	-	mA
TX Supply Current(Continuous)	-	100	-	mA
Sleep Supply Current	-	1	-	mA
Storage Temperature	-20	-	+85	°C

■ Power Consumption

Mode	Avg.
Standby	1mA
Transmit	65mA
Receive	60mA

■ Operating Conditions

Voltage Range	3.3V±0.3V
Operating Temperature Range	-20°C ~ 60°C
Storage Temperature Range	-20°C ~ 80°C
Relative Humidity (Operating)	≤90%
Relative Humidity (Storage)	≤90%

1.5 Radio Characteristics

■ MB-C041 Class1 Module

	Frequency (GHz)	Min	Typ	Max	BT Spec.	Unit
Sensitivity at 0.1%BER	2.402	-	-80	-86	≤ -70	dBm
	2.441	-	-80	-86		dBm
	2.480	-	-80	-86		dBm
RF Transmit Power	2.402	15.0	16.0		≤15	dBm
	2.441	15.0	16.0			dBm
	2.480	15.0	16.0			dBm
Initial Carrier Frequency Tolerance	2.402	-	5	75	75	kHz
	2.441	-	5	75		kHz
	2.480	-	5	75		kHz
20dB bandwidth for modulated carrier		-	900	1000	≤ 1000	kHz
Drift (Five slots packet)		-	15	-	40	kHz
Drift Rate		-	13	-	20	kHz
$\Delta f_{1\text{avg}}$ "Maximum Modulation"	2.402GHz	140	165	175	$140 < \Delta f_{1\text{avg}}$	kHz
	2.441GHz	140	165	175		kHz
	2.480GHz	140	165	175		kHz
$\Delta f_{2\text{max}}$ "Minimum Modulation"	2.402GHz	115	190	-	115	kHz
	2.441GHz	115	190	-		kHz
	2.480GHz	115	190	-		kHz

1.6 Reference Schematics

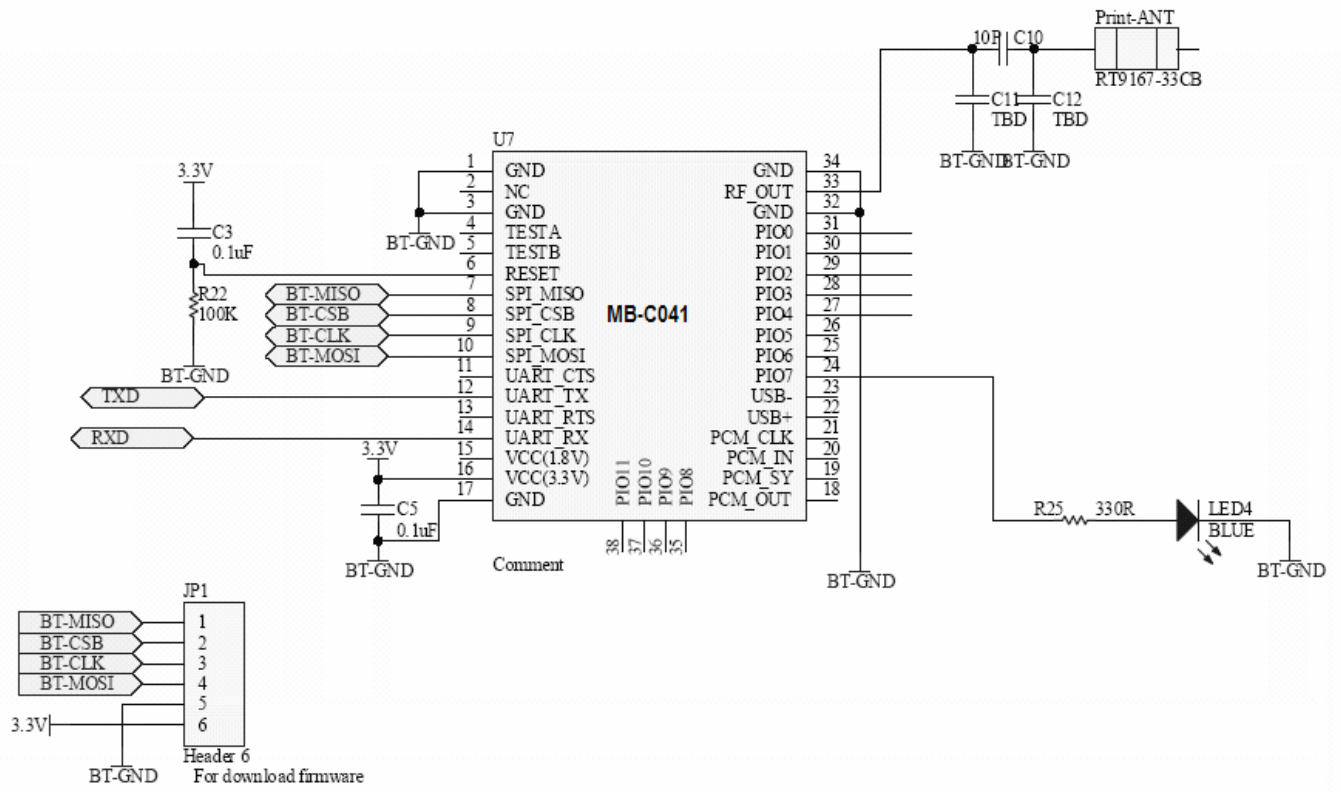



2. Software / Profile

Stack / Profile	MB-C041 (Class1 BT2.0 module)
SPP	V
HCI	V

3. Pcking & Label Infomation

3.1 Label Information

■ PCB Label

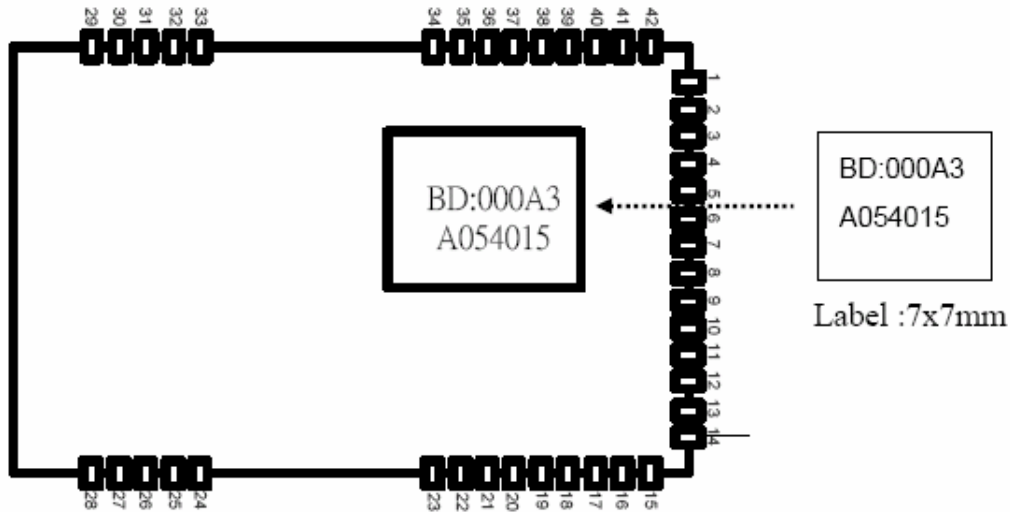
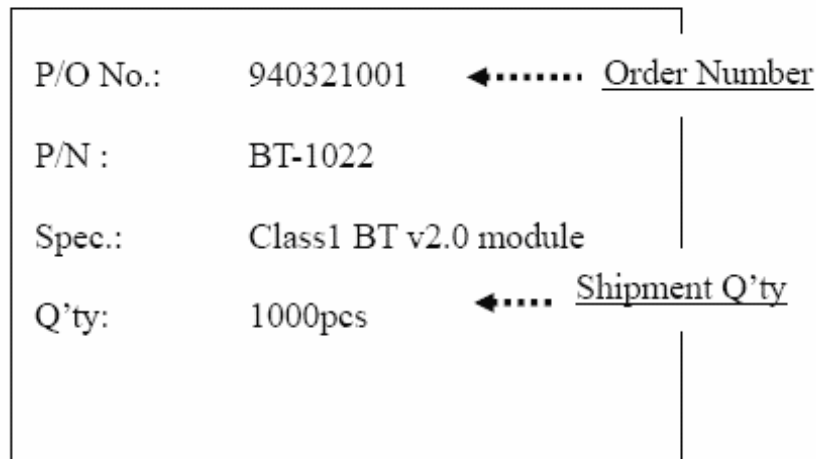

Fig 3.1.1 Class1 BT2.0 Module PCBA Label

■ Carton Label



Dimension :102x102mm

Fig 3.1.2 Class1 Carton Label

3.2 Packaging

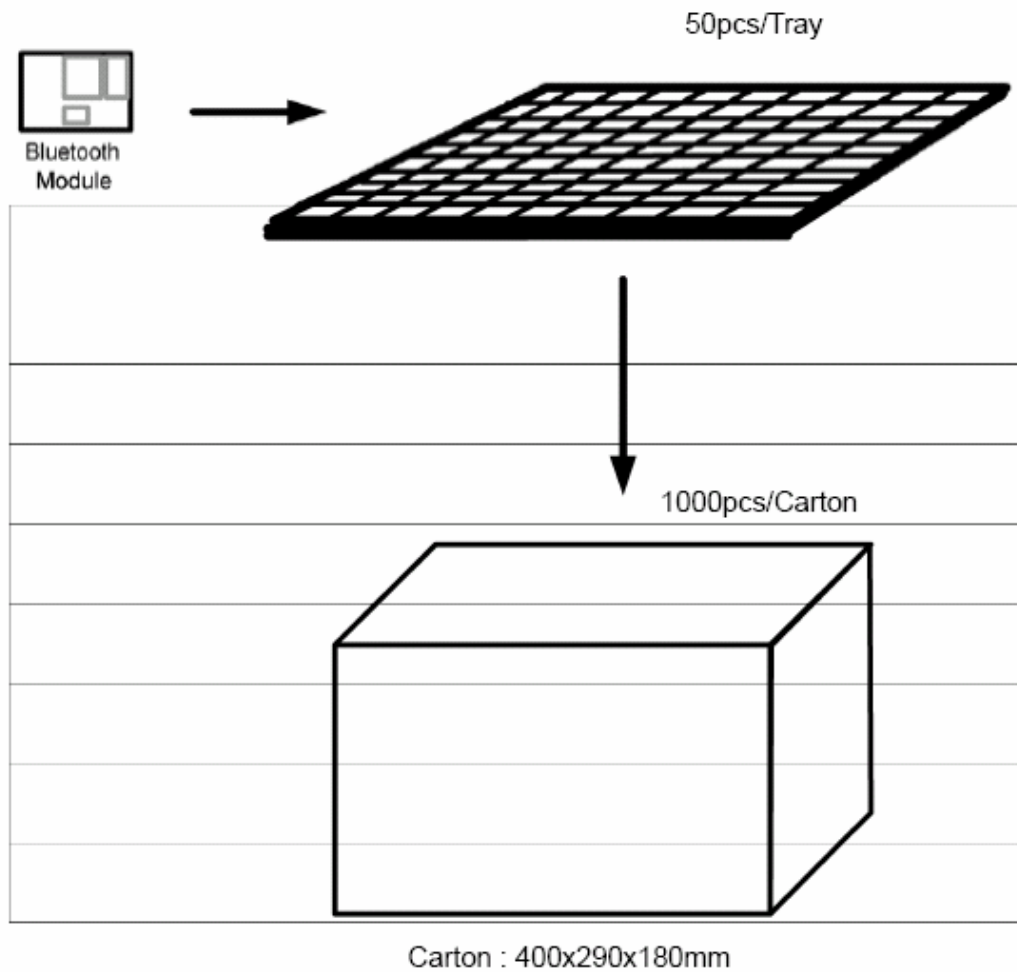

4. Standard Setup Information

	Parameter		Value
1	Baud Rate		9600
2	Pin Code Prompt		Disable
3	Local Name		SPP
4	LED PIN24(PIO 7)	Power on	Flash 26 times[ON time frame: 80ms, OFF time frame: 140ms]
		Connect	Flash with ON one time within 1 second,[ON time frame: 35ms]
		Disconnected	Flash with ON one time within 3 seconds,[ON time frame : 35ms]

5. Customization Information

	Parameter		Value
1	Baud Rate		
2	Pin Code Prompt		
3	Local Name		
4	LED PIN24(PIO 7)	Connected	
		Disconnected	