

# ADC1412D series

Dual 14-bit ADC; 65 Msps, 80 Msps, 105 Msps or 125 Msps;  
CMOS or LVDS DDR digital outputs

Rev. 03 — 6 August 2010

Preliminary data sheet

## 1. General description

---

The ADC1412D is a dual channel 14-bit Analog-to-Digital Converter (ADC) optimized for high dynamic performances and low power consumption at sample rates up to 125 Msps. Pipelined architecture and output error correction ensure the ADC1412D is accurate enough to guarantee zero missing codes over the entire operating range. Supplied from a single 3 V source, it can handle output logic levels from 1.8 V to 3.3 V in Complementary Metal Oxide Semiconductor (CMOS) mode because of a separate digital output supply. It supports the Low Voltage Differential Signalling (LVDS) Double Data Rate (DDR) output standard. An integrated Serial Peripheral Interface (SPI) allows the user to easily configure the ADC. The device also includes an SPI programmable full-scale to allow a flexible input voltage range of 1 V to 2 V (peak-to-peak). With excellent dynamic performance from the baseband to input frequencies of 170 MHz or more, the ADC1412D is ideal for use in communications, imaging and medical applications.

## 2. Features and benefits

---

- SNR, 72 dBFS
- SFDR, 86 dBc
- Sample rate up to 125 Msps
- Clock input divider by 2 for less jitter contribution
- Single 3 V supply
- Flexible input voltage range: 1 V to 2 V (p-p)
- CMOS or LVDS DDR digital outputs
- Pin and software compatible with ADC1212D series
- HVQFN64 package
- Input bandwidth, 600 MHz
- Power dissipation, 855 mW at 80 Msps
- Serial Peripheral Interface (SPI)
- Duty cycle stabilizer
- Fast Out-of-Range (OTR) detection
- INL  $\pm 1$  LSB, DNL  $\pm 0.5$  LSB
- Offset binary, two's complement, gray code
- Power-down and Sleep modes

## 3. Applications

---

- Wireless and wired broadband communications
- Spectral analysis
- Ultrasound equipment
- Portable instrumentation
- Imaging systems
- Software defined radio



### 4. Ordering information

Table 1. Ordering information

Type number	f <sub>s</sub> (MSPS)	Package		Version
		Name	Description	
ADC1412D125HN/C1	125	HVQFN64	plastic thermal enhanced very thin quad flat package; no leads; 64 terminals; body 9 × 9 × 0.85 mm	SOT804-3
ADC1412D105HN/C1	105	HVQFN64	plastic thermal enhanced very thin quad flat package; no leads; 64 terminals; body 9 × 9 × 0.85 mm	SOT804-3
ADC1412D080HN/C1	80	HVQFN64	plastic thermal enhanced very thin quad flat package; no leads; 64 terminals; body 9 × 9 × 0.85 mm	SOT804-3
ADC1412D065HN/C1	65	HVQFN64	plastic thermal enhanced very thin quad flat package; no leads; 64 terminals; body 9 × 9 × 0.85 mm	SOT804-3

### 5. Block diagram

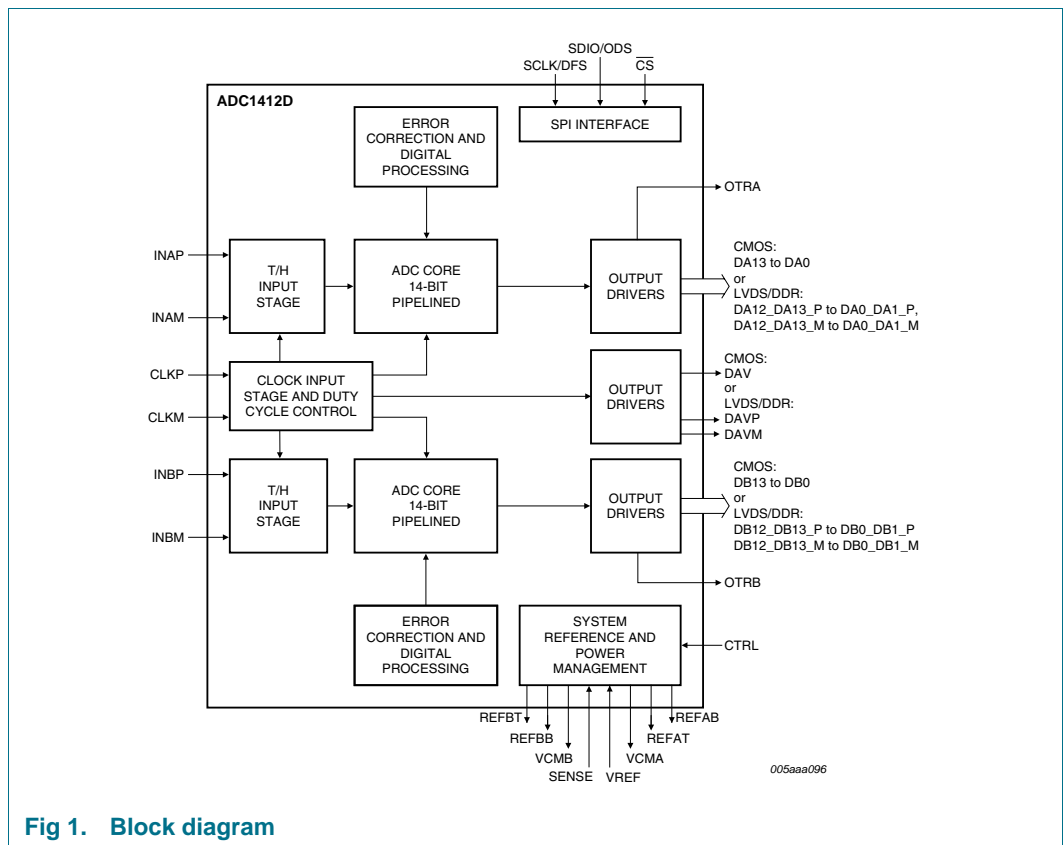

Fig 1. Block diagram

6. Pinning information

6.1 CMOS outputs selected

6.1.1 Pinning

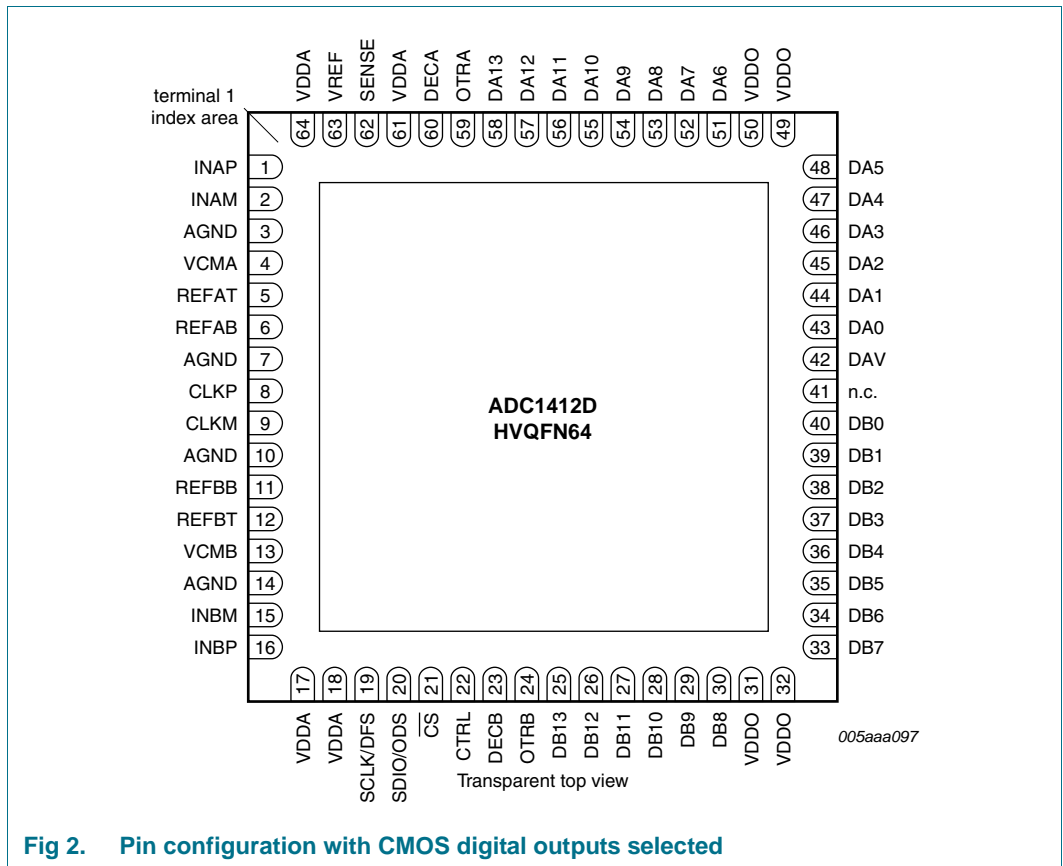

Fig 2. Pin configuration with CMOS digital outputs selected

6.1.2 Pin description

Table 2. Pin description (CMOS digital outputs)

Symbol	Pin	Type <sup>[1]</sup>	Description
INAP	1	I	analog input; channel A
INAM	2	I	complementary analog input; channel A
AGND	3	G	analog ground
VCMA	4	O	common-mode output voltage; channel A
REFAT	5	O	top reference; channel A
REFAB	6	O	bottom reference; channel A
AGND	7	G	analog ground
CLKP	8	I	clock input
CLKM	9	I	complementary clock input
AGND	10	G	analog ground
REFBB	11	O	bottom reference; channel B
REFBT	12	O	top reference; channel B

Table 2. Pin description (CMOS digital outputs) ...continued

Symbol	Pin	Type <sup>[1]</sup>	Description
VCMB	13	O	common-mode output voltage; channel B
AGND	14	G	analog ground
INBM	15	I	complementary analog input; channel B
INBP	16	I	analog input; channel B
VDDA	17	P	analog power supply
VDDA	18	P	analog power supply
SCLK/DFS	19	I	SPI clock/data format select
SDIO/ODS	20	I/O	SPI data IO/output data standard
$\overline{\text{CS}}$	21	I	SPI chip select
CTRL	22	I	control mode select
DECB	23	O	regulator decoupling node; channel B
OTRB	24	O	out of range; channel B
DB13	25	O	data output bit 13 (Most Significant Bit (MSB)); channel B
DB12	26	O	data output bit 12; channel B
DB11	27	O	data output bit 11; channel B
DB10	28	O	data output bit 10; channel B
DB9	29	O	data output bit 9; channel B
DB8	30	O	data output bit 8; channel B
VDDO	31	P	output power supply
VDDO	32	P	output power supply
DB7	33	O	data output bit 7; channel B
DB6	34	O	data output bit 6; channel B
DB5	35	O	data output bit 5; channel B
DB4	36	O	data output bit 4; channel B
DB3	37	O	data output bit 3; channel B
DB2	38	O	data output bit 2; channel B
DB1	39	O	data output bit 1; channel B
DB0	40	O	data output bit 0 (Least Significant Bit (LSB)); channel B
n.c.	41	-	not connected
DAV	42	O	data valid output clock
DA0	43	O	data output bit 0 (LSB); channel A
DA1	44	O	data output bit 1; channel A
DA2	45	O	data output bit 2; channel A
DA3	46	O	data output bit 3; channel A
DA4	47	O	data output bit 4; channel A
DA5	48	O	data output bit 5; channel A
VDDO	49	P	output power supply
VDDO	50	P	output power supply
DA6	51	O	data output bit 6; channel A
DA7	52	O	data output bit 7; channel A
DA8	53	O	data output bit 8; channel A
DA9	54	O	data output bit 9; channel A
DA10	55	O	data output bit 10; channel A
DA11	56	O	data output bit 11; channel A

Table 2. Pin description (CMOS digital outputs) ...continued

Symbol	Pin	Type <sup>[1]</sup>	Description
DA12	57	O	data output bit 12; channel A
DA13	58	O	data output bit 13 (MSB); channel A
OTRA	59	O	out-of-range; channel A
DECA	60	O	regulator decoupling node; channel A
VDDA	61	P	analog power supply
SENSE	62	I	reference programming pin
VREF	63	I/O	voltage reference input/output
VDDA	64	P	analog power supply

[1] P: power supply; G: ground; I: input; O: output; I/O: input/output.

## 6.2 LVDS/DDR outputs selected

### 6.2.1 Pinning

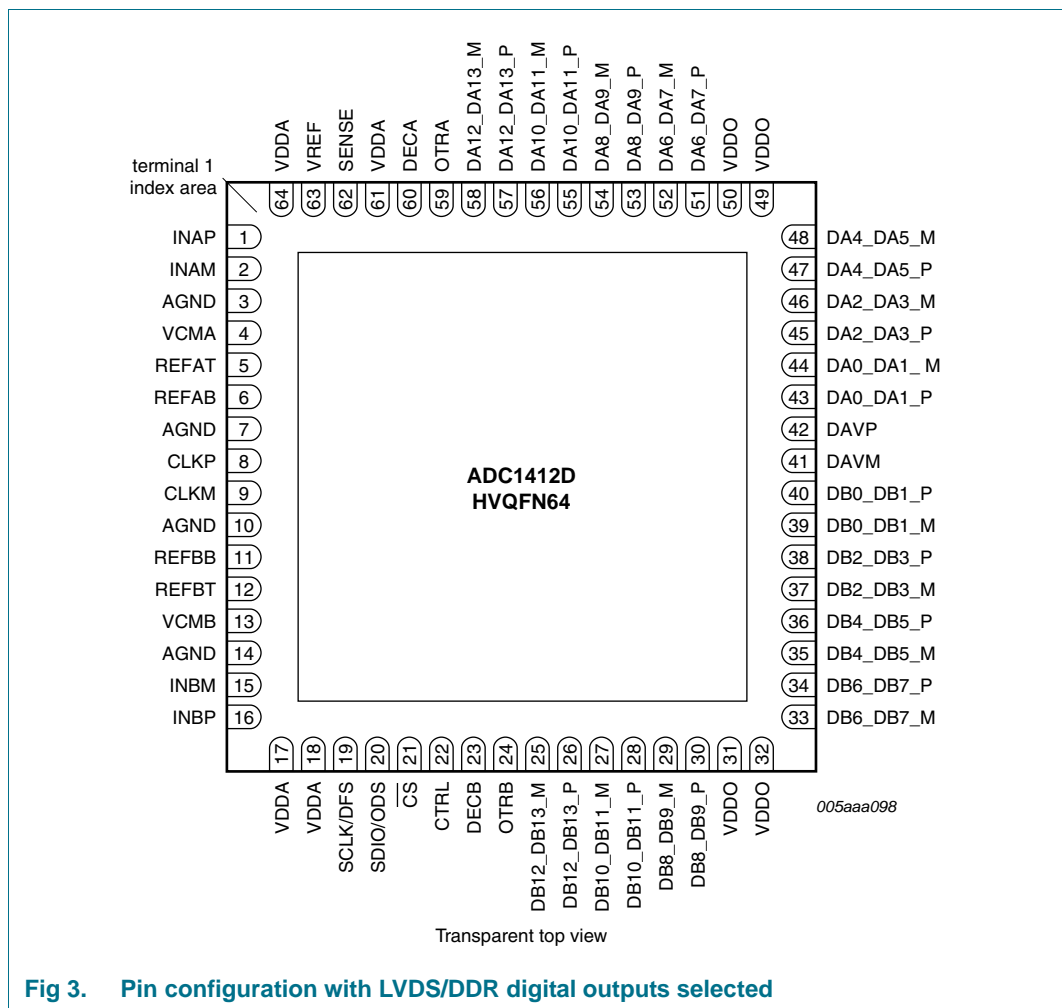

## 6.2.2 Pin description

Table 3. Pin description (LVDS/DDR) digital outputs [1]

Symbol	Pin	Type <sup>[2]</sup>	Description
DB12_DB13_M	25	O	differential output data DB12 and DB13 multiplexed, complement
DB12_DB13_P	26	O	differential output data DB12 and DB13 multiplexed, true
DB10_DB11_M	27	O	differential output data DB10 and DB11 multiplexed, complement
DB10_DB11_P	28	O	differential output data DB10 and DB11 multiplexed, true
DB8_DB9_M	29	O	differential output data DB8 and DB9 multiplexed, complement
DB8_DB9_P	30	O	differential output data DB8 and DB9 multiplexed, true
DB6_DB7_M	33	O	differential output data DB6 and DB7 multiplexed, complement
DB6_DB7_P	34	O	differential output data DB6 and DB7 multiplexed, true
DB4_DB5_M	35	O	differential output data DB4 and DB5 multiplexed, complement
DB4_DB5_P	36	O	differential output data DB4 and DB5 multiplexed, true
DB2_DB3_M	37	O	differential output data DB2 and DB3 multiplexed, complement
DB2_DB3_P	38	O	differential output data DB2 and DB3 multiplexed, true
DB0_DB1_M	39	O	differential output data DB0 and DB1 multiplexed, complement
DB0_DB1_P	40	O	differential output data DB0 and DB1 multiplexed, true
DAVM	41	O	data valid output clock, complement
DAVP	42	O	data valid output clock, true
DA0_DA1_P	43	O	differential output data DA0 and DA1 multiplexed, true
DA0_DA1_M	44	O	differential output data DA0 and DA1 multiplexed, complement
DA2_DA3_P	45	O	differential output data DA2 and DA3 multiplexed, true
DA2_DA3_M	46	O	differential output data DA2 and DA3 multiplexed, complement
DA4_DA5_P	47	O	differential output data DA4 and DA5 multiplexed, true
DA4_DA5_M	48	O	differential output data DA4 and DA5 multiplexed, complement
DA6_DA7_P	51	O	differential output data DA6 and DA7 multiplexed, true
DA6_DA7_M	52	O	differential output data DA6 and DA7 multiplexed, complement
DA8_DA9_P	53	O	differential output data DA8 and DA9 multiplexed, true
DA8_DA9_M	54	O	differential output data DA8 and DA9 multiplexed, complement
DA10_DA11_P	55	O	differential output data DA10 and DA11 multiplexed, true
DA10_DA11_M	56	O	differential output data DA10 and DA11 multiplexed, complement
DA12_DA13_P	57	O	differential output data DA12 and DA13 multiplexed, true
DA12_DA13_M	58	O	differential output data DA12 and DA13 multiplexed, complement

[1] Pins 1 to 24, pin 59 to 64 and pins 31, 32, 49 and 50 are the same for both CMOS and LVDS DDR outputs (see [Table 2](#)).

[2] P: power supply; G: ground; I: input; O: output; I/O: input/output.

## 7. Limiting values

**Table 4. Limiting values**

In accordance with the Absolute Maximum Rating System (IEC 60134).

Symbol	Parameter	Conditions	Min	Max	Unit
$V_O$	output voltage	pins DA13 to DA0 and DB13 to DB0 or pins DA12_DA13_P to DA0_DA1_P, DA12_DA13_M to DA0_DA1_M, DB12_DB13_P to DB0_DB1_P and DB12_DB13_M to DB0_DB1_M	-0.4	+3.9	V
$V_{DDA}$	analog supply voltage		-0.4	+3.9	V
$V_{DDO}$	output supply voltage		-0.4	+3.9	V
$T_{stg}$	storage temperature		-55	+125	°C
$T_{amb}$	ambient temperature		-40	+85	°C
$T_j$	junction temperature		-	125	°C

## 8. Thermal characteristics

**Table 5. Thermal characteristics**

Symbol	Parameter	Conditions	Typ	Unit
$R_{th(j-a)}$	thermal resistance from junction to ambient		[1] 15.6	K/W
$R_{th(j-c)}$	thermal resistance from junction to case		[1] 6.3	K/W

[1] Value for six layers board in still air with a minimum of 64 thermal via.

## 9. Static characteristics

**Table 6. Static characteristics**<sup>[1]</sup>

Symbol	Parameter	Conditions	Min	Typ	Max	Unit
<b>Supplies</b>						
$V_{DDA}$	analog supply voltage		2.85	3.0	3.4	V
$V_{DDO}$	output supply voltage	CMOS mode	1.65	1.8	3.6	V
		LVDS DDR mode	2.85	3.0	3.6	V
$I_{DDA}$	analog supply current	$f_{clk} = 125$ Msps; $f_i = 70$ MHz	-	400	-	mA
$I_{DDO}$	output supply current	CMOS mode; $f_{clk} = 125$ Msps; $f_i = 70$ MHz	-	23	-	mA
		LVDS DDR mode: $f_{clk} = 125$ Msps; $f_i = 70$ MHz	-	90	-	mA

**Table 6. Static characteristics**<sup>[1]</sup> ...continued

Symbol	Parameter	Conditions	Min	Typ	Max	Unit
P	power dissipation	ADC1412D125; analog supply only	-	1200	-	mW
		ADC1412D105; analog supply only	-	1100	-	mW
		ADC1412D080; analog supply only	-	855	-	mW
		ADC1412D065; analog supply only	-	795	-	mW
		Power-down mode	-	25	-	mW
		Sleep mode	-	80	-	mW

**Clock inputs: pins CLKP and CLKM**

**LVPECL**

$V_{i(\text{clk})\text{dif}}$	differential clock input voltage	peak-to-peak	-	$\pm 1.6$	-	V
-------------------------------	----------------------------------	--------------	---	-----------	---	---

**LVDS**

$V_{i(\text{clk})\text{dif}}$	differential clock input voltage	peak-to-peak	-	$\pm 0.70$	-	V
-------------------------------	----------------------------------	--------------	---	------------	---	---

**SINE**

$V_{i(\text{clk})\text{dif}}$	differential clock input voltage	peak-to-peak	$\pm 0.8$	$\pm 3.0$	-	V
-------------------------------	----------------------------------	--------------	-----------	-----------	---	---

**LVC MOS**

$V_{IL}$	LOW-level input voltage		-	-	$0.3V_{DDA}$	V
----------	-------------------------	--	---	---	--------------	---

$V_{IH}$	HIGH-level input voltage		$0.7V_{DDA}$	-	-	V
----------	--------------------------	--	--------------	---	---	---

**Logic input: pin CTRL**

$V_{IL}$	LOW-level input voltage		-	0	-	V
----------	-------------------------	--	---	---	---	---

	LOW-medium level	-	$0.3V_{DDA}$	-	V
--	------------------	---	--------------	---	---

	medium-HIGH level	-	$0.6V_{DDA}$	-	V
--	-------------------	---	--------------	---	---

$V_{IH}$	HIGH-level input voltage		-	$V_{DDA}$	-	V
----------	--------------------------	--	---	-----------	---	---

$I_{IL}$	LOW-level input current		<td>	-	<td>	$\mu\text{A}$
----------	-------------------------	--	------	---	------	---------------

$I_{IH}$	HIGH-level input current		-10	-	+10	$\mu\text{A}$
----------	--------------------------	--	-----	---	-----	---------------

**Serial peripheral interface: pins CS, SDIO/ODS, SCLK/DFS**

$V_{IL}$	LOW-level input voltage		0	-	$0.3V_{DDA}$	V
----------	-------------------------	--	---	---	--------------	---

$V_{IH}$	HIGH-level input voltage		$0.7V_{DDA}$	-	$V_{DDA}$	V
----------	--------------------------	--	--------------	---	-----------	---

$I_{IL}$	LOW-level input current		-10	-	+10	$\mu\text{A}$
----------	-------------------------	--	-----	---	-----	---------------

$I_{IH}$	HIGH-level input current		-50	-	+50	$\mu\text{A}$
----------	--------------------------	--	-----	---	-----	---------------

$C_i$	input capacitance		-	4	-	pF
-------	-------------------	--	---	---	---	----

**Digital outputs, CMOS mode: pins DA13 to DA0, DB13 to DB0, OTRA, OTRB and DAV**

**Output levels,  $V_{DDO} = 3\text{ V}$**

$V_{OL}$	LOW-level output voltage	$I_{OL} = \text{<td>}$	OGND	-	$0.2V_{DDO}$	V
----------	--------------------------	------------------------	------	---	--------------	---

$V_{OH}$	HIGH-level output voltage	$I_{OH} = \text{<td>}$	$0.8V_{DDO}$	-	$V_{DDO}$	V
----------	---------------------------	------------------------	--------------	---	-----------	---

$I_{OL}$	LOW-level output current	3-state; output level = 0 V	-	<td>	-	$\mu\text{A}$
----------	--------------------------	-----------------------------	---	------	---	---------------

$I_{OH}$	HIGH-level output current	3-state; output level = $V_{DDA}$	-	<td>	-	$\mu\text{A}$
----------	---------------------------	-----------------------------------	---	------	---	---------------

$C_o$	output capacitance	high impedance; see <a href="#">Table 10</a>	-	3	-	pF
-------	--------------------	--	---	---	---	----

**Output levels,  $V_{DDO} = 1.8\text{ V}$**

$V_{OL}$	LOW-level output voltage	$I_{OL} = \text{<td>}$	OGND	-	$0.2V_{DDO}$	V
----------	--------------------------	------------------------	------	---	--------------	---



Table 6. Static characteristics<sup>[1]</sup> ...continued

Symbol	Parameter	Conditions	Min	Typ	Max	Unit
V <sub>OH</sub>	HIGH-level output voltage	I <sub>OH</sub> = <td>	0.8V <sub>DDO</sub>	-	V <sub>DDO</sub>	V
<b>Digital outputs, LVDS DDR mode: pins DA12_DA13_P to DA0_DA1_P, DA12_DA13_M to DA0_DA1_M, DB12_DB13_P to DB0_DB1_P, DB12_DB13_M to DB0_DB1_M, DAVP and DAVM</b>						
Output levels, V <sub>DDO</sub> = 3 V only, R <sub>L</sub> = 100 Ω						
V <sub>O(offset)</sub>	output offset voltage	output buffer current set to 3.5 mA	-	1.2	-	V
V <sub>O(dif)</sub>	differential output voltage	output buffer current set to 3.5 mA	-	350	-	mV
C <sub>O</sub>	output capacitance		-	<td>	-	pF
<b>Analog inputs: pins INAP, INAM, INBP and INBM</b>						
I <sub>I</sub>	input current		-5	-	+5	μA
R <sub>I</sub>	input resistance		-	<td>	-	Ω
C <sub>I</sub>	input capacitance		-	5	-	pF
V <sub>I(cm)</sub>	common-mode input voltage	V <sub>INAP</sub> = V <sub>INAM</sub> ; V <sub>INBP</sub> = V <sub>INBM</sub>	0.9	1.5	2	V
B <sub>i</sub>	input bandwidth		-	600	-	MHz
V <sub>I(dif)</sub>	differential input voltage	peak-to-peak	1	-	2	V
<b>Common mode output voltage: pins VCMA and VCMB</b>						
V <sub>O(cm)</sub>	common-mode output voltage		-	0.5V <sub>DDA</sub>	-	V
I <sub>O(cm)</sub>	common-mode output current		-	<td>	-	μA
<b>I/O reference voltage: pin VREF</b>						
V <sub>VREF</sub>	voltage on pin VREF	output	-	0.5 to 1	-	V
		input	0.5	-	1	V
<b>Accuracy</b>						
INL	integral non-linearity		-5	±1	+5	LSB
DNL	differential non-linearity	guaranteed no missing codes	-0.95	±0.5	+0.95	LSB
E <sub>offset</sub>	offset error		-	±2	-	mV
E <sub>G</sub>	gain error	full scale	-	±0.5	-	%
M <sub>G(CTC)</sub>	channel-to-channel gain matching		-	<td>	-	%
<b>Supply</b>						
PSRR	power supply rejection ratio	100 mV (p-p) on V <sub>DDA</sub>	-	35	-	dBc

[1] Typical values measured at V<sub>DDA</sub> = 3 V, V<sub>DDO</sub> = 1.8 V, T<sub>amb</sub> = 25 °C and C<sub>L</sub> = 5 pF; minimum and maximum values are across the full temperature range T<sub>amb</sub> = -40 °C to +85 °C at V<sub>DDA</sub> = 3 V, V<sub>DDO</sub> = 1.8 V; V<sub>INAP</sub> - V<sub>INAM</sub> = -1 dBFS; V<sub>INBP</sub> - V<sub>INBM</sub> = -1 dBFS; internal reference mode; applied to CMOS and LVDS interface; unless otherwise specified.

## 10. Dynamic characteristics

### 10.1 Dynamic characteristics

Table 7. Dynamic characteristics<sup>[1]</sup>

Symbol	Parameter	Conditions	ADC1412D065			ADC1412D080			ADC1412D105			ADC1412D125			Unit
			Min	Typ	Max	Min	Typ	Max	Min	Typ	Max	Min	Typ	Max	
<b>Analog signal processing</b>															
$\alpha_{2H}$	second harmonic level	$f_i = 3$ MHz	-	87	-	-	87	-	-	86	-	-	88	-	dBc
		$f_i = 30$ MHz	-	86	-	-	86	-	-	86	-	-	87	-	dBc
		$f_i = 70$ MHz	-	85	-	-	85	-	-	84	-	-	85	-	dBc
		$f_i = 170$ MHz	-	82	-	-	82	-	-	81	-	-	83	-	dBc
$\alpha_{3H}$	third harmonic level	$f_i = 3$ MHz	-	86	-	-	86	-	-	85	-	-	87	-	dBc
		$f_i = 30$ MHz	-	85	-	-	85	-	-	85	-	-	86	-	dBc
		$f_i = 70$ MHz	-	84	-	-	84	-	-	83	-	-	84	-	dBc
		$f_i = 170$ MHz	-	81	-	-	81	-	-	80	-	-	82	-	dBc
THD	total harmonic distortion	$f_i = 3$ MHz	-	85	-	-	85	-	-	84	-	-	86	-	dBc
		$f_i = 30$ MHz	-	84	-	-	84	-	-	84	-	-	85	-	dBc
		$f_i = 70$ MHz	-	83	-	-	83	-	-	82	-	-	83	-	dBc
		$f_i = 170$ MHz	-	80	-	-	80	-	-	79	-	-	81	-	dBc
ENOB	effective number of bits	$f_i = 3$ MHz	-	11.7	-	-	11.7	-	-	11.6	-	-	11.6	-	bit
		$f_i = 30$ MHz	-	11.6	-	-	11.5	-	-	11.5	-	-	11.5	-	bit
		$f_i = 70$ MHz	-	11.5	-	-	11.5	-	-	11.4	-	-	11.4	-	bit
		$f_i = 170$ MHz	-	11.4	-	-	11.4	-	-	11.3	-	-	11.3	-	bit
SNR	signal-to-noise ratio	$f_i = 3$ MHz	-	72.1	-	-	72.0	-	-	71.8	-	-	71.4	-	dBFS
		$f_i = 30$ MHz	-	71.3	-	-	71.2	-	-	71.2	-	-	71.1	-	dBFS
		$f_i = 70$ MHz	-	70.7	-	-	70.7	-	-	70.6	-	-	70.5	-	dBFS
		$f_i = 170$ MHz	-	70.2	-	-	70.1	-	-	70.0	-	-	69.9	-	dBFS
SFDR	spurious-free dynamic range	$f_i = 3$ MHz	-	86	-	-	86	-	-	85	-	-	87	-	dBc
		$f_i = 30$ MHz	-	85	-	-	85	-	-	85	-	-	86	-	dBc
		$f_i = 70$ MHz	-	84	-	-	84	-	-	83	-	-	84	-	dBc
		$f_i = 170$ MHz	-	81	-	-	81	-	-	80	-	-	82	-	dBc

**Table 7. Dynamic characteristics**<sup>[1]</sup> ...continued

Symbol	Parameter	Conditions	ADC1412D065			ADC1412D080			ADC1412D105			ADC1412D125			Unit
			Min	Typ	Max	Min	Typ	Max	Min	Typ	Max	Min	Typ	Max	
IMD	Intermodulation distortion	f <sub>i</sub> = 3 MHz	-	89	-	-	89	-	-	88	-	-	89	-	dBc
		f <sub>i</sub> = 30 MHz	-	88	-	-	88	-	-	88	-	-	88	-	dBc
		f <sub>i</sub> = 70 MHz	-	87	-	-	87	-	-	86	-	-	86	-	dBc
		f <sub>i</sub> = 170 MHz	-	84	-	-	85	-	-	83	-	-	84	-	dBc
α <sub>ct(ch)</sub>	channel crosstalk	f <sub>i</sub> = 70 MHz	-	100	-	-	100	-	-	100	-	-	100	-	dBc

[1] Typical values measured at V<sub>DDA</sub> = 3 V, V<sub>DDO</sub> = 1.8 V, T<sub>amb</sub> = 25 °C and C<sub>L</sub> = 5 pF; minimum and maximum values are across the full temperature range T<sub>amb</sub> = -40 °C to +85 °C at V<sub>DDA</sub> = 3 V, V<sub>DDO</sub> = 1.8 V; V<sub>INAP</sub> - V<sub>INAM</sub> = -1 dBFS; V<sub>INBP</sub> - V<sub>INBM</sub> = -1 dBFS; internal reference mode; applied to CMOS and LVDS interface; unless otherwise specified.

## 10.2 Clock and digital output timing

**Table 8. Clock and digital output timing characteristics**<sup>[1]</sup>

Symbol	Parameter	Conditions	ADC1412D065			ADC1412D080			ADC1412D105			ADC1412D125			Unit	
			Min	Typ	Max	Min	Typ	Max	Min	Typ	Max	Min	Typ	Max		
<b>Clock timing input: pins CLKP and CLKM</b>																
f <sub>clk</sub>	clock frequency		20	-	65	60	-	80	75	-	105	100	-	125	MHz	
t <sub>lat(data)</sub>	data latency time		-	14	-	-	14	-	-	14	-	-	14	-	clock cycles	
δ <sub>clk</sub>	clock duty cycle	DCS_EN = 1	30	50	70	30	50	70	30	50	70	30	50	70	%	
		DCS_EN = 0	45	50	55	45	50	55	45	50	55	45	50	55	%	
t <sub>d(s)</sub>	sampling delay time		-	0.8	-	-	0.8	-	-	0.8	-	-	0.8	-	ns	
t <sub>wake</sub>	wake-up time		-	tbd	-	-	tbd	-	-	tbd	-	-	tbd	-	ns	
<b>CMOS mode timing: pins DA13 to DA0, DB13 to DB0 and DAV</b>																
t <sub>PD</sub>	propagation delay	DATA	-	3.9	-	-	3.9	-	-	3.9	-	-	3.9	-	ns	
		DAV	-	4.2	-	-	4.2	-	-	4.2	-	-	4.2	-	ns	
t <sub>su</sub>	set-up time		-	8.6	-	-	7.4	-	-	6.1	-	-	5.7	-	ns	
t <sub>h</sub>	hold time		-	4.8	-	-	3.4	-	-	1.8	-	-	1.4	-	ns	
t <sub>r</sub>	rise time	DATA	[2]	0.5	-	2.4	0.5	-	2.4	0.5	-	2.4	0.5	-	2.4	ns
		DAV		0.5	-	2.4	0.5	-	2.4	0.5	-	2.4	0.5	-	2.4	ns
t <sub>f</sub>	fall time	DATA	[2]	0.5	-	2.4	0.5	-	2.4	0.5	-	2.4	0.5	-	2.4	ns

Table 8. Clock and digital output timing characteristics<sup>[1]</sup> ...continued

Symbol	Parameter	Conditions	ADC1412D065			ADC1412D080			ADC1412D105			ADC1412D125			Unit	
			Min	Typ	Max	Min	Typ	Max	Min	Typ	Max	Min	Typ	Max		
LVDS DDR mode timing: pins DA12_DA13_P to DA0_DA1_P, DA12_DA13_M to DA0_DA1_M, DB12_DB13_P to DB0_DB1_P, DB12_DB13_M to DB0_DB1_M, DAVP and DAVM																
t <sub>PD</sub>	propagation delay	DATA	-	3.9	-	-	3.9	-	-	3.9	-	-	3.9	-	ns	
		DAV	-	4.2	-	-	4.2	-	-	4.2	-	-	4.2	-	ns	
t <sub>su</sub>	set-up time		-	5.1	-	-	3.5	-	-	2.1	-	-	1.4	-	ns	
t <sub>h</sub>	hold time		-	2.0	-	-	2.0	-	-	2.0	-	-	2.0	-	ns	
t <sub>r</sub>	rise time	DATA	[3]	50	100	200	50	100	200	50	100	200	50	100	200	ps
		DAV		50	100	200	50	100	200	50	100	200	50	100	200	ps
t <sub>f</sub>	fall time	DATA	[3]	50	100	200	50	100	200	50	100	200	50	100	200	ps
		DAV		50	100	200	50	100	200	50	100	200	50	100	200	ps

[1] Typical values measured at V<sub>DDA</sub> = 3 V, V<sub>DDO</sub> = 1.8 V, T<sub>amb</sub> = 25 °C and C<sub>L</sub> = 5 pF; minimum and maximum values are across the full temperature range T<sub>amb</sub> = -40 °C to +85 °C at V<sub>DDA</sub> = 3 V, V<sub>DDO</sub> = 1.8 V; V<sub>INAP</sub> - V<sub>INAM</sub> = -1 dBFS; V<sub>INBP</sub> - V<sub>INBM</sub> = -1 dBFS; unless otherwise specified.

[2] Measured between 20 % to 80 % of V<sub>DDO</sub>.

[3] Rise time measured from -50 mV to +50 mV; fall time measured from +50 mV to -50 mV.

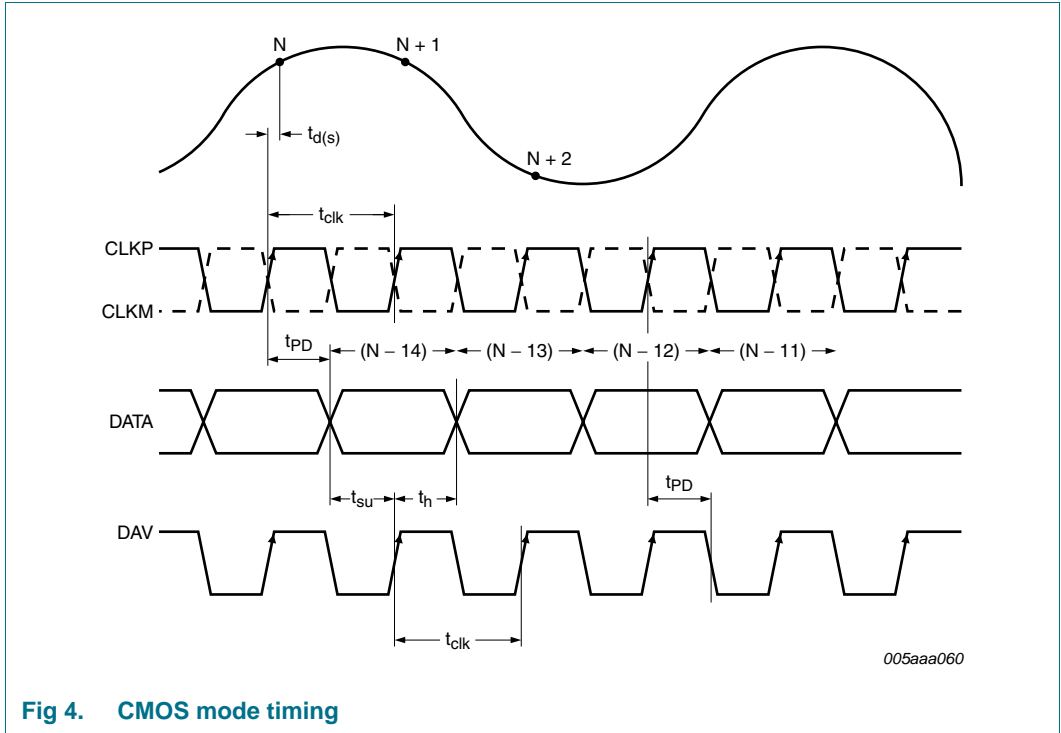

Fig 4. CMOS mode timing

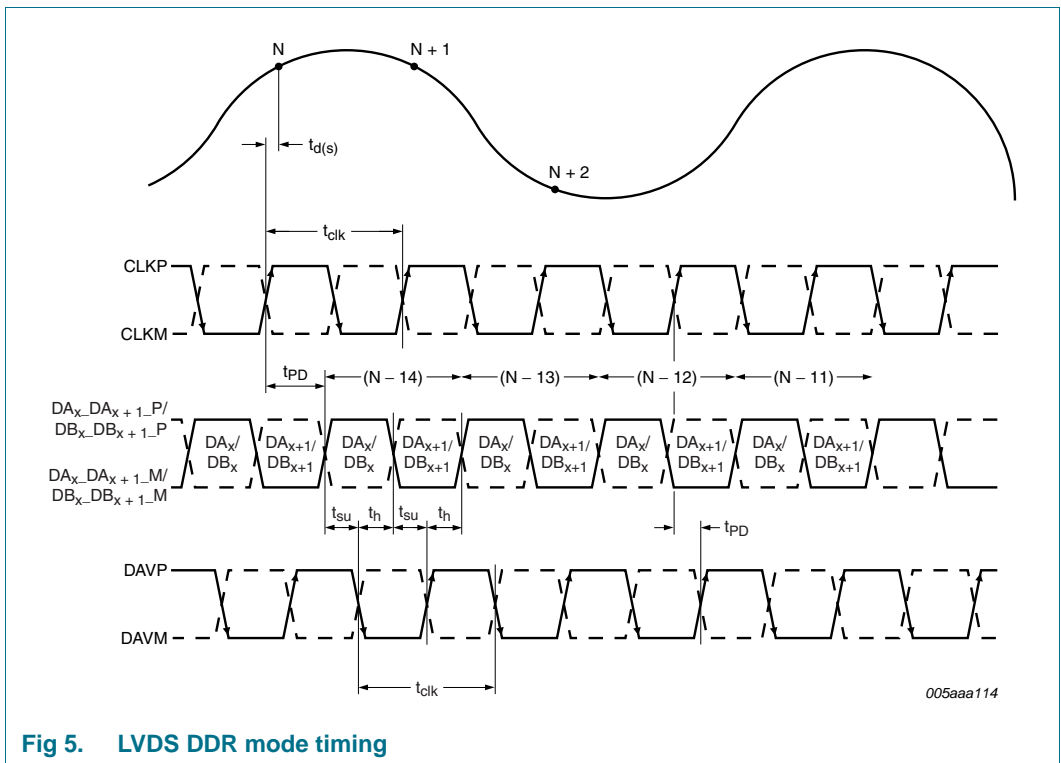

Fig 5. LVDS DDR mode timing

10.3 SPI timings

Table 9. Characteristics

Symbol	Parameter	Conditions	Min	Typ	Max	Unit
<b>SPI timings</b>						
$t_{w(SCLK)}$	SCLK pulse width		40	-	-	ns
$t_{w(SCLKH)}$	SCLK HIGH pulse width		16	-	-	ns
$t_{w(SCLKL)}$	SCLK LOW pulse width		16	-	-	ns
$t_{su}$	set-up time	data to SCLK HIGH	5	-	-	ns
		$\overline{CS}$ to SCLK HIGH	5	-	-	ns
$t_h$	hold time	data to SCLK HIGH	2	-	-	ns
		$\overline{CS}$ to SCLK HIGH	2	-	-	ns
$f_{clk(max)}$	maximum clock frequency		-	-	25	MHz

[1] Typical values measured at  $V_{DDA} = 3\text{ V}$ ,  $V_{DDO} = 1.8\text{ V}$ ,  $T_{amb} = 25\text{ }^\circ\text{C}$  and  $C_L = 5\text{ pF}$ ; minimum and maximum values are across the full temperature range  $T_{amb} = -40\text{ }^\circ\text{C}$  to  $+85\text{ }^\circ\text{C}$  at  $V_{DDA} = 3\text{ V}$ ,  $V_{DDO} = 1.8\text{ V}$

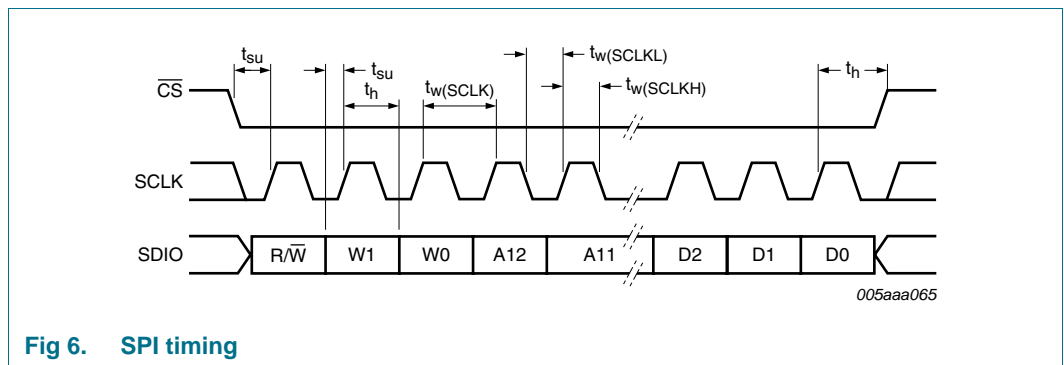

Fig 6. SPI timing

## 11. Application information

### 11.1 Device control

The ADC1412D can be controlled via the Serial Peripheral Interface (SPI control mode) or directly via the I/O pins (Pin control mode).

#### 11.1.1 SPI and Pin control modes

The device enters Pin control mode at power-up and remains in this mode as long as pin  $\overline{CS}$  is held HIGH. In Pin control mode, the SPI pins SDIO,  $\overline{CS}$  and SCLK are used as static control pins.

SPI control mode is enabled by forcing pin  $\overline{CS}$  LOW. Once SPI control mode has been enabled, the device remains in this mode. The transition from Pin control mode to SPI control mode is illustrated in [Figure 7](#).

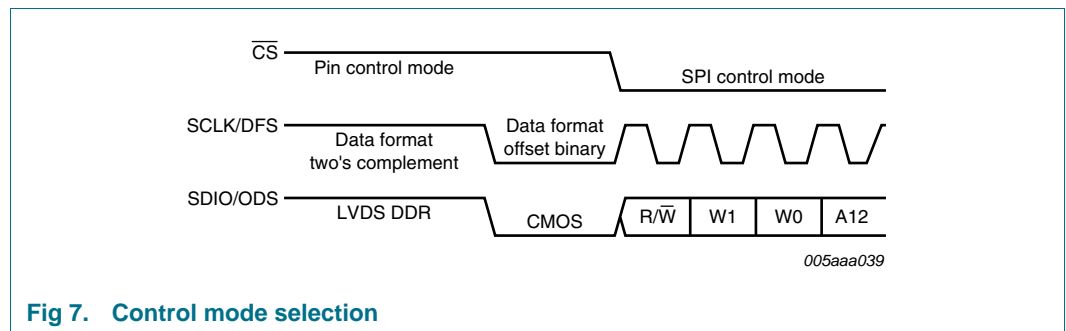

Fig 7. Control mode selection

When the device enters SPI control mode, the output data standard and data format are determined by the level on pin SDIO as soon as a transition is triggered by a falling edge on  $\overline{CS}$ .

#### 11.1.2 Operating mode selection

The active ADC1412D operating mode (Power-up, Power-down or Sleep) can be selected via the SPI interface (see [Table 21](#)) or by using pin CTRL in Pin control mode, as described in [Table 10](#).

Table 10. Operating mode selection via pin CTRL

Pin CTRL	Operating mode	Output high-Z
0	Power-down	yes
$0.3V_{DDA}$	Sleep	yes
$0.6V_{DDA}$	Power-up	yes
$V_{DDA}$	Power-up	no

#### 11.1.3 Selecting the output data standard

The output data standard (CMOS or LVDS DDR) can be selected via the SPI interface (see [Table 24](#)) or by using pin ODS in Pin control mode. LVDS DDR is selected when ODS is HIGH, otherwise CMOS is selected.

11.1.4 Selecting the output data format

The output data format can be selected via the SPI interface (offset binary, two’s complement or gray code; see [Table 24](#)) or by using pin DFS in Pin control mode (offset binary or two’s complement). Offset binary is selected when DFS is LOW. When DFS is HIGH, two’s complement is selected.

11.2 Analog inputs

11.2.1 Input stage

The analog input of the ADC1412D supports a differential or a single-ended input drive. Optimal performance is achieved using differential inputs with the common-mode input voltage ( $V_{I(cm)}$ ) on pins INAP, INAM, INBP and INBM set to  $0.5V_{DDA}$ .

The full-scale analog input voltage range is configurable between 1 V (p-p) and 2 V (p-p) via a programmable internal reference (see [Section 11.3](#) and [Table 23](#)).

The equivalent circuit of the sample and hold input stage, including ElectroStatic Discharge (ESD) protection and circuit and package parasitics, is shown in [Figure 8](#).

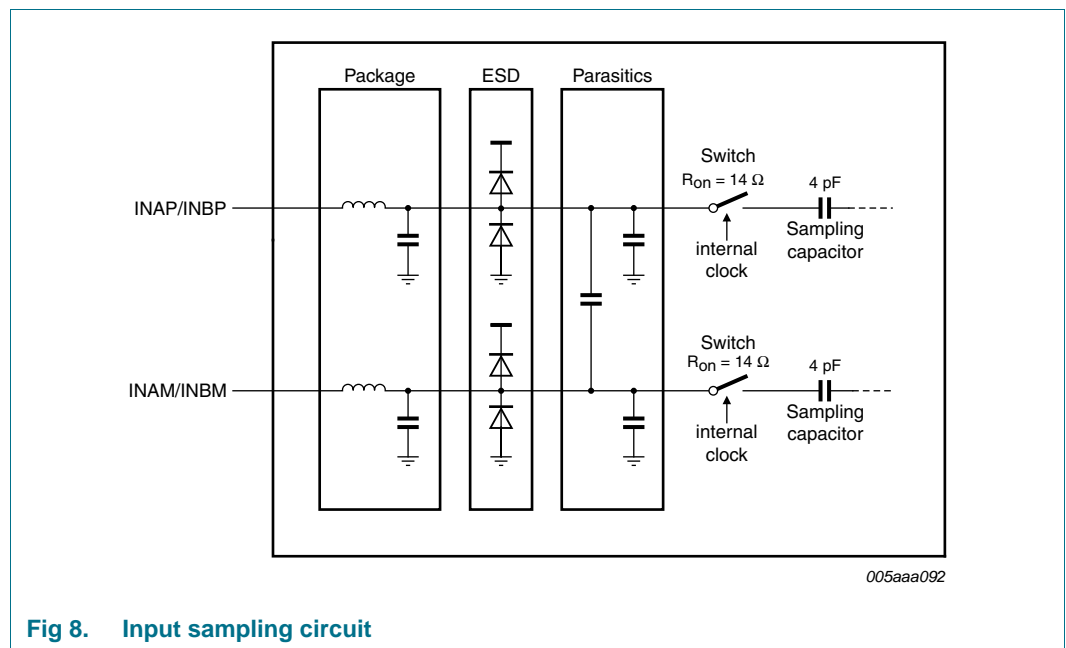

Fig 8. Input sampling circuit

The sample phase occurs when the internal clock (derived from the clock signal on pin CLKP/CLKM) is HIGH. The voltage is then held on the sampling capacitors. When the clock signal goes LOW, the stage enters the hold phase and the voltage information is transmitted to the ADC core.

11.2.2 Anti-kickback circuitry

Anti-kickback circuitry (RC filter in [Figure 9](#)) is needed to counteract the effects of charge injection generated by the sampling capacitance.

The RC filter is also used to filter noise from the signal before it reaches the sampling stage. The value of the capacitor should be chosen to maximize noise attenuation without degrading the settling time excessively.



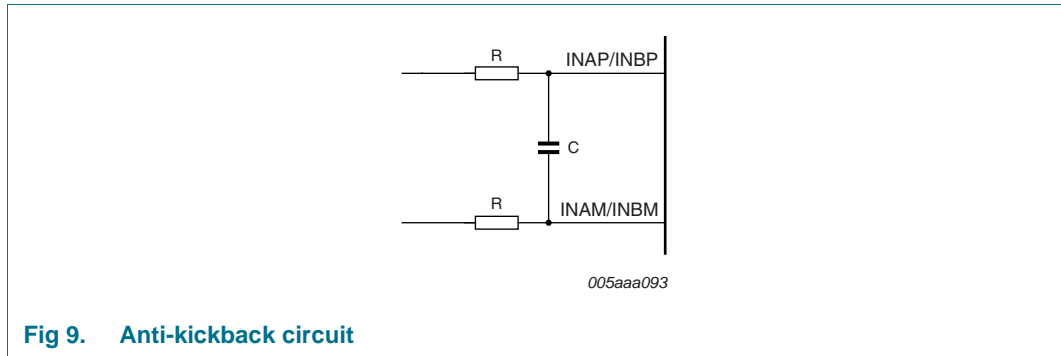

**Fig 9. Anti-kickback circuit**

The component values are determined by the input frequency and should be selected so as not to affect the input bandwidth.

**Table 11. RC coupling versus input frequency, typical values**

Input frequency (MHz)	R ( $\Omega$ )	C (pF)
3	25	12
70	12	8
170	12	8

**11.2.3 Transformer**

The configuration of the transformer circuit is determined by the input frequency. The configuration shown in [Figure 10](#) would be suitable for a baseband application.

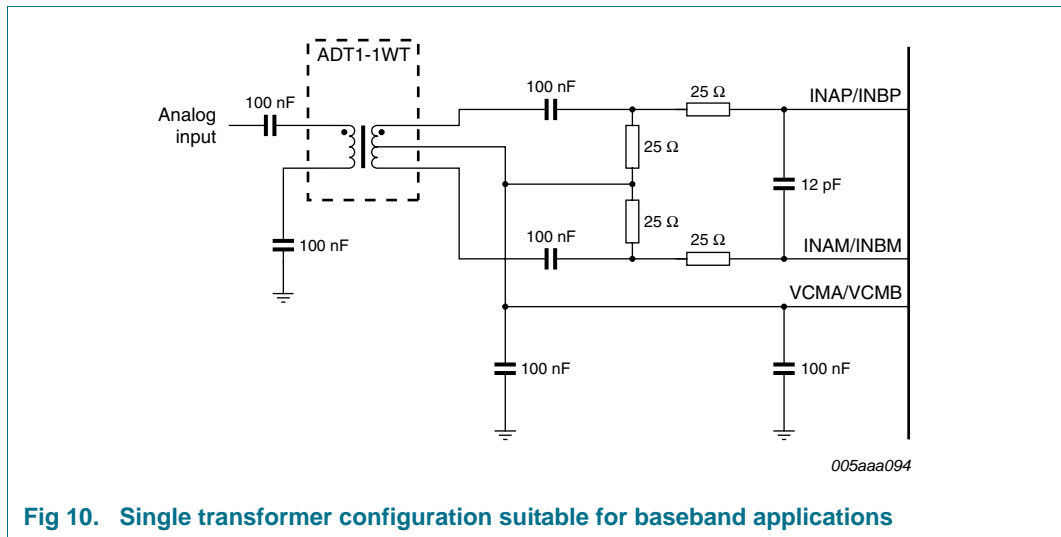

**Fig 10. Single transformer configuration suitable for baseband applications**

The configuration shown in [Figure 11](#) is recommended for high frequency applications. In both cases, the choice of transformer is a compromise between cost and performance.

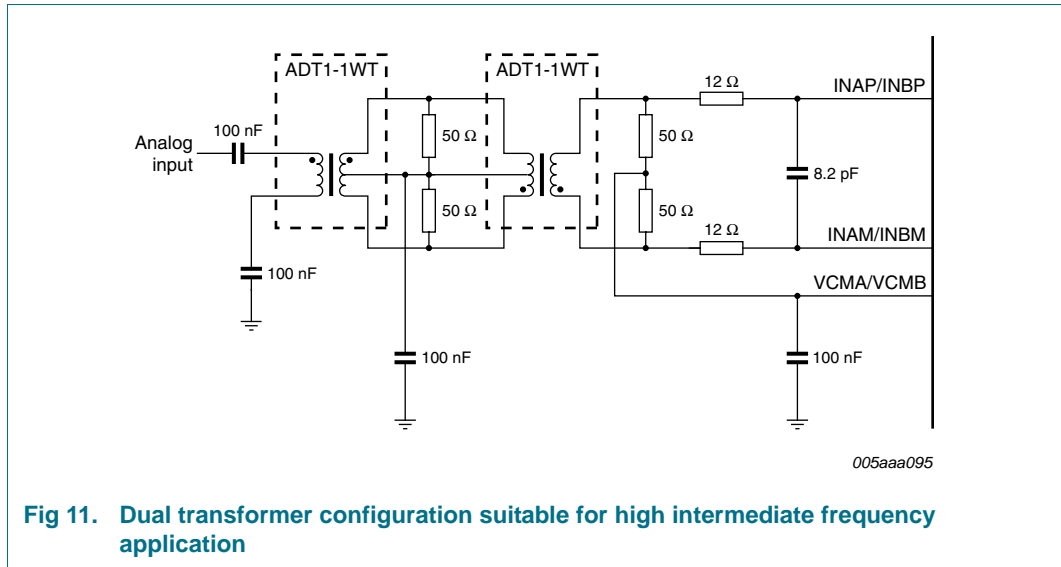

### 11.3 System reference and power management

#### 11.3.1 Internal/external references

The ADC1412D has a stable and accurate built-in internal reference voltage to adjust the ADC full-scale. This reference voltage can be set internally via SPI or with pins VREF and SENSE (programmable in 1 dB steps between 0 dB and -6 dB via control bits INTREF when bit INTREF\_EN = logic 1; see [Table 23](#)). See [Figure 13](#) to [Figure 16](#). The equivalent reference circuit is shown in [Figure 12](#). External reference is also possible by providing a voltage on pin VREF as described in [Figure 15](#).

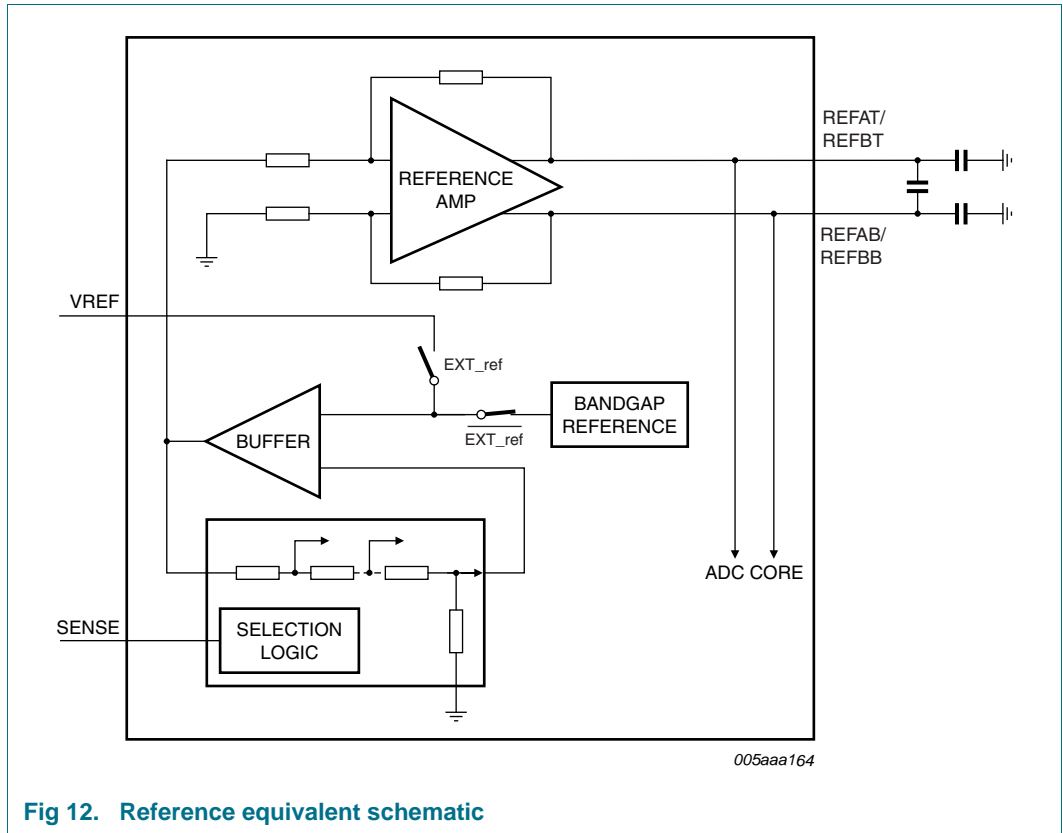

Fig 12. Reference equivalent schematic

If bit INTREF\_EN is set to 0, the reference voltage is determined either internally or externally as detailed in Table 12.

Table 12. Reference selection

Selection	SPI bit INTREF_EN	SENSE pin	VREF pin	Full-scale (p-p)
internal (Figure 13)	0	AGND	330 pF capacitor to AGND	2 V
internal (Figure 14)	0	pin VREF connected to pin SENSE and via a 330 pF capacitor to AGND		1 V
external (Figure 15)	0	V <sub>DDA</sub>	external voltage between 0.5 V and 1 V <sup>[1]</sup>	1 V to 2 V
internal via SPI (Figure 16)	1	pin VREF connected to pin SENSE and via 330 pF capacitor to AGND		1 V to 2 V

[1] The voltage on pin VREF is doubled internally to generate the internal reference voltage.

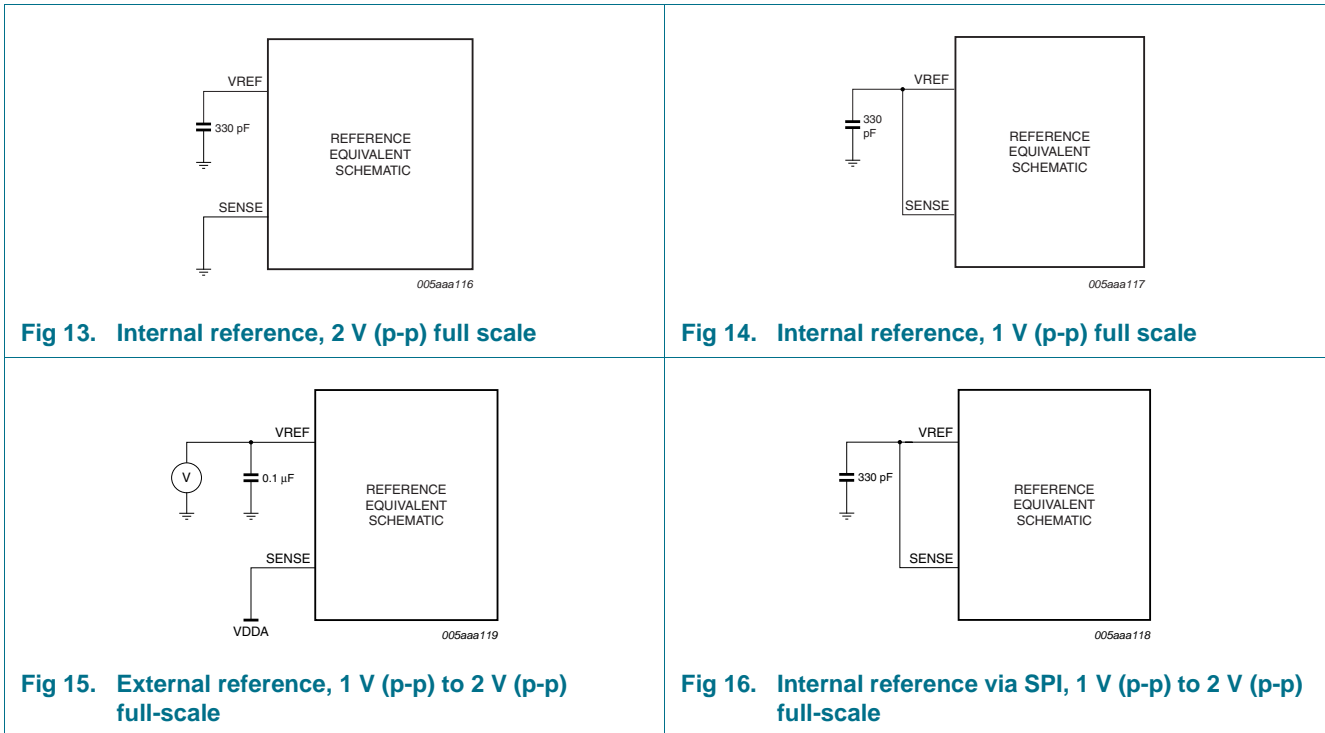

Figure 13 to Figure 16 illustrate how to connect the SENSE and VREF pins to select the required reference voltage source.

11.3.2 Reference gain control

The reference gain is programmable between 0 dB to -6 dB in 1 dB steps via the SPI (see Table 23). The corresponding full-scale input voltage range varies between 2 V (p-p) and 1 V (p-p), as shown in Table 13.

Table 13. Reference SPI gain control

INTREF	Gain	Full-scale (p-p)
000	0 dB	2 V
001	-1 dB	1.78 V
010	-2 dB	1.59 V
011	-3 dB	1.42 V
100	-4 dB	1.26 V
101	-5 dB	1.12 V
110	-6 dB	1 V
111	reserved	x

11.3.3 Common-mode output voltage ( $V_{O(cm)}$ )

A 0.1  $\mu$ F filter capacitor should be connected between pin VCMA/VCMB and ground to ensure a low-noise common-mode output voltage. When AC-coupled, pin VCMA/VCMB can then be used to set the common-mode reference for the analog inputs, for instance via a transformer middle point.

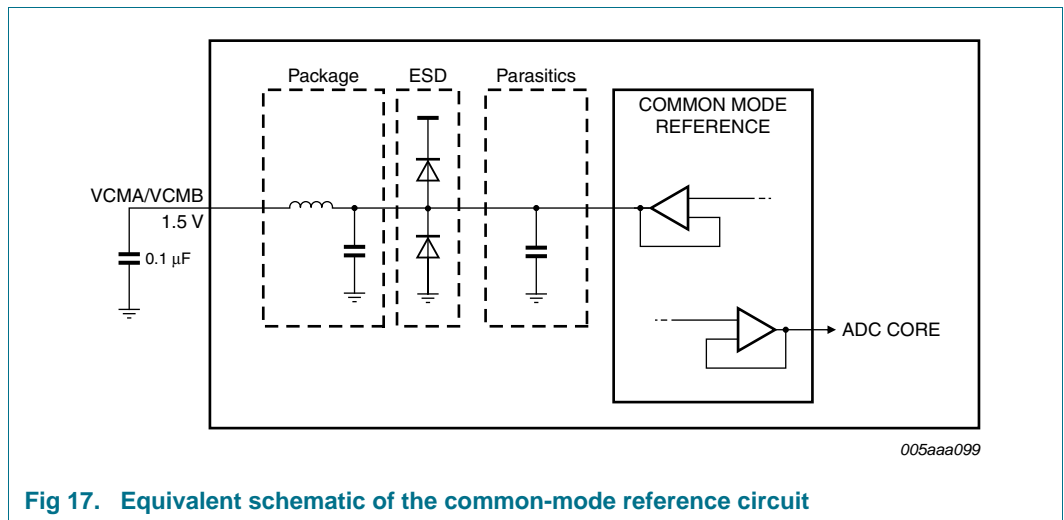

Fig 17. Equivalent schematic of the common-mode reference circuit

11.3.4 Biasing

The common-mode input voltage ( $V_{I(cm)}$ ) on pins INAP/INBP and INAM/INBM should be set externally to  $0.5V_{DDA}$  for optimal performance and should always be between 0.9 V and 2 V.

11.4 Clock input

11.4.1 Drive modes

The ADC1412D can be driven differentially (SINE, LVPECL or LVDS) with little or no degradation on dynamic performance. It can also be driven by a single-ended Low Voltage Complementary Metal Oxide Semiconductor (LVCMOS) signal connected to pin CLKP (pin CLKM should be connected to ground via a capacitor) or CLKM (pin CLKP should be connected to ground via a capacitor). A differential clock is preferred for optimal performance. An LVPECL clock is recommended.

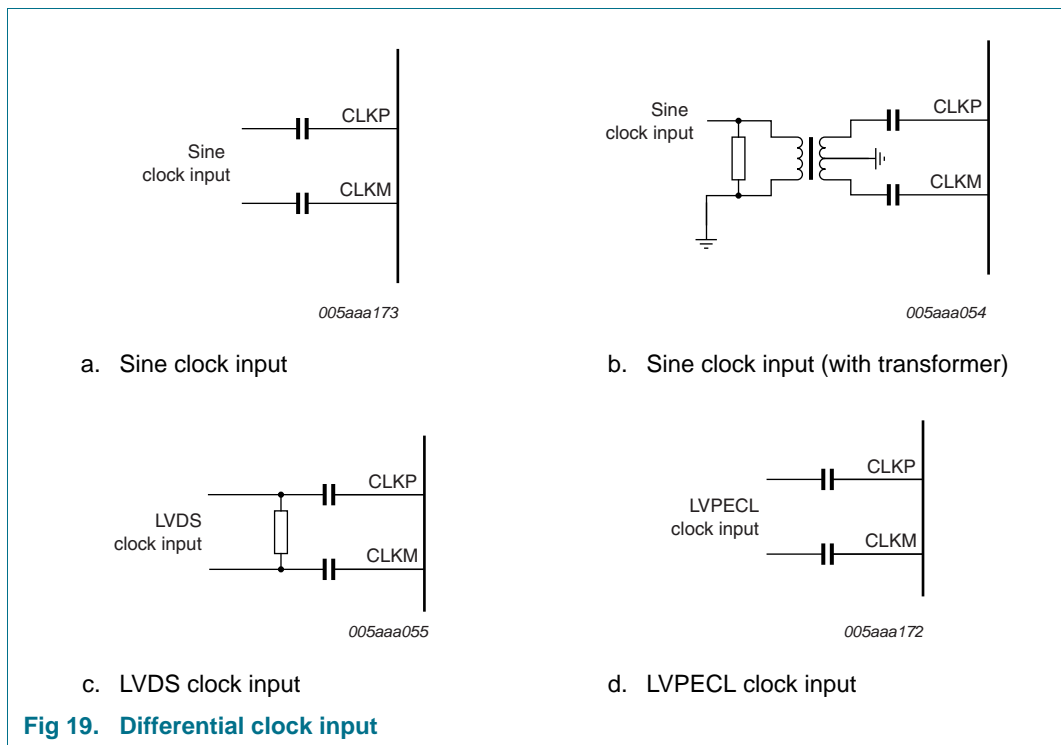
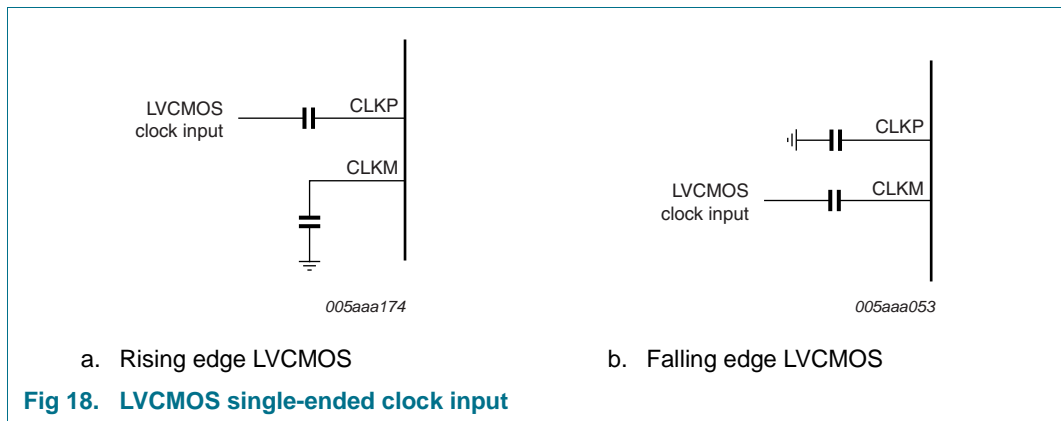

11.4.2 Equivalent input circuit

The equivalent circuit of the input clock buffer is shown in Figure 20. The common-mode voltage of the differential input stage is set via internal 5 kΩ resistors.

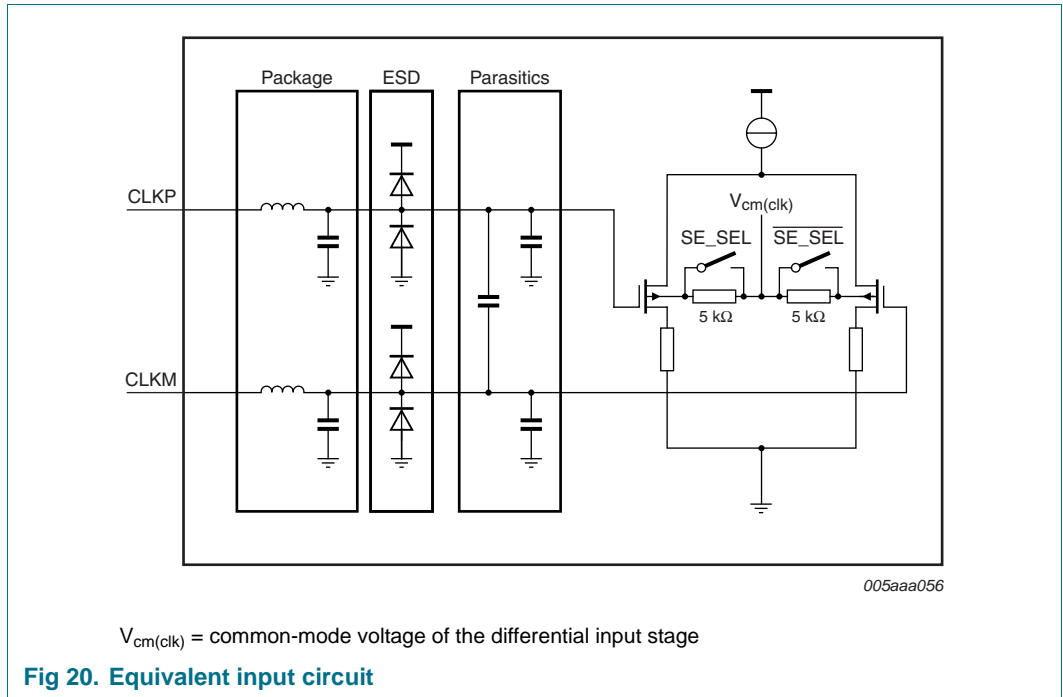

Single-ended or differential clock inputs can be selected via the SPI interface (see Table 22). If single-ended is enabled, the input pin (CLKM or CLKP) is selected via control bit SE\_SEL.

If single-ended is implemented without setting bit SE\_SEL to the appropriate value, the unused pin should be connected to ground via a capacitor.

11.4.3 Duty cycle stabilizer

The duty cycle stabilizer can improve the overall performance of the ADC by compensating the duty cycle of the input clock signal. When the duty cycle stabilizer is active (bit DCS\_EN = logic 1; see Table 22), the circuit can handle signals with duty cycles of between 30 % and 70 % (typical). When the duty cycle stabilizer is disabled (DCS\_EN = logic 0), the input clock signal should have a duty cycle of between 45 % and 55 %.

11.4.4 Clock input divider

The ADC1412D contains an input clock divider that divides the incoming clock by a factor of 2 (when bit CLKDIV = logic 1; see Table 22). This feature allows the user to deliver a higher clock frequency with better jitter performance, leading to a better SNR result once acquisition has been performed.

11.5 Digital outputs

11.5.1 Digital output buffers: CMOS mode

The digital output buffers can be configured as CMOS by setting bit LVDS\_CMOS to logic 0 (see [Table 24](#)).

Each digital output has a dedicated output buffer. The equivalent circuit of the CMOS digital output buffer is shown in [Figure 21](#). The buffer is powered by a separate OGND/V<sub>DDO</sub> to ensure 1.8 V to 3.3 V compatibility and is isolated from the ADC core. Each buffer can be loaded by a maximum of 10 pF.

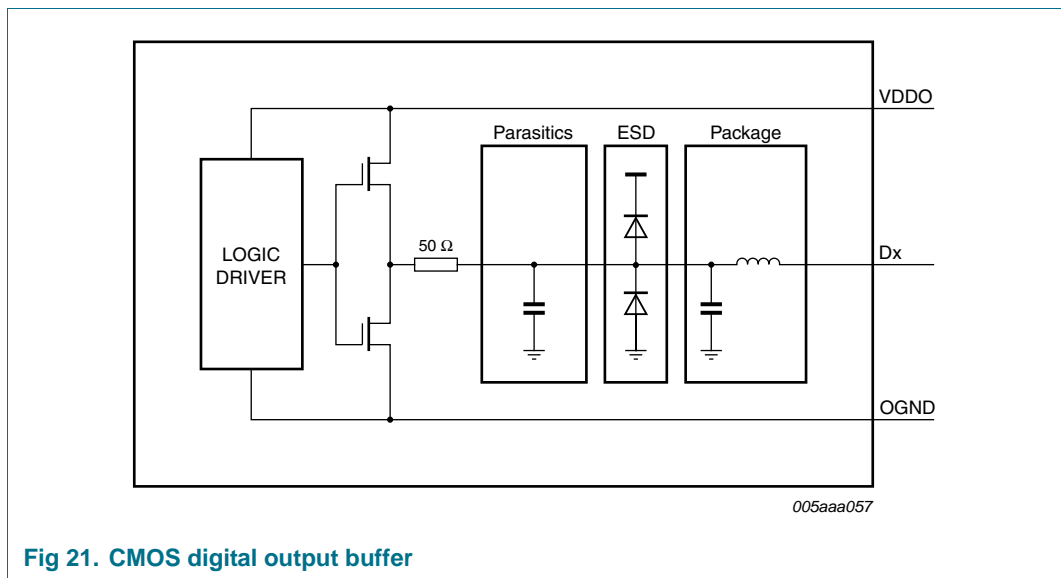

Fig 21. CMOS digital output buffer

The output resistance is 50 Ω and is the combination of an internal resistor and the equivalent output resistance of the buffer. There is no need for an external damping resistor. The drive strength of both DATA and DAV buffers can be programmed via the SPI in order to adjust the rise and fall times of the output digital signals (see [Table 31](#)).



11.5.2 Digital output buffers: LVDS DDR mode

The digital output buffers can be configured as LVDS DDR by setting bit LVDS\_CMOS to logic 1 (see Table 24).

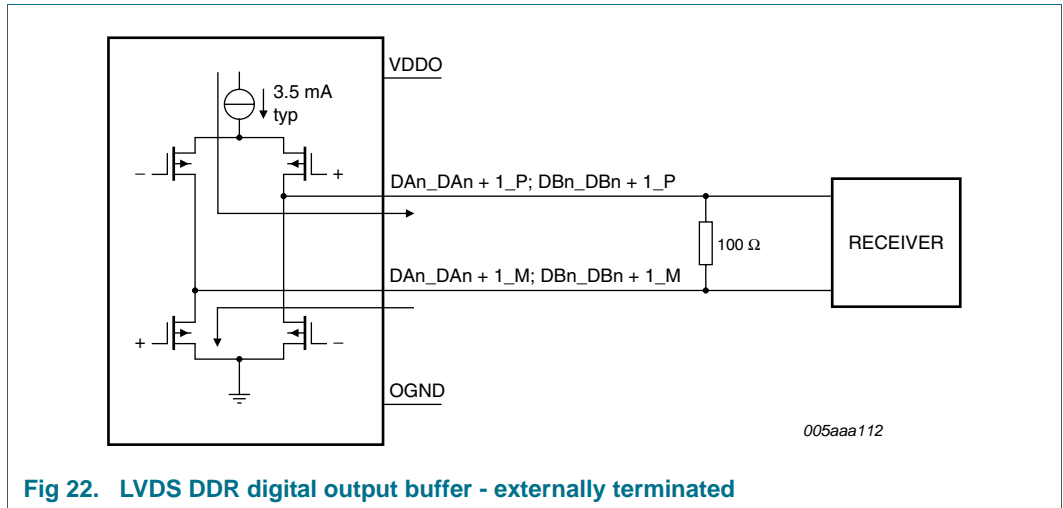

Fig 22. LVDS DDR digital output buffer - externally terminated

Each output should be terminated externally with a 100 Ω resistor (typical) at the receiver side (Figure 22) or internally via SPI control bits LVDS\_INT\_TER (see Figure 23 and Table 33).

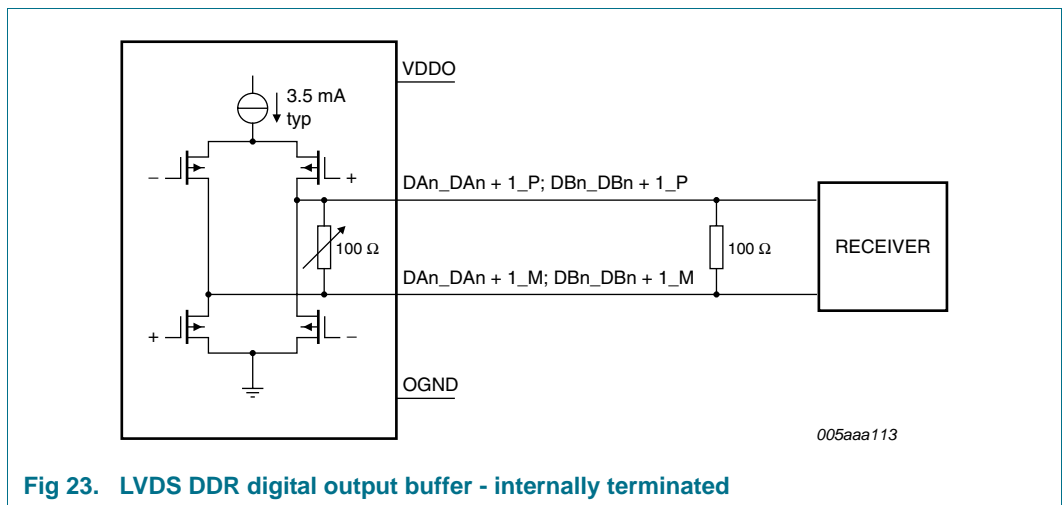

Fig 23. LVDS DDR digital output buffer - internally terminated

The default LVDS DDR output buffer current is set to 3.5 mA. It can be programmed via the SPI (bits DAVI and DATAI; see Table 32) in order to adjust the output logic voltage levels.

Table 14. LVDS DDR output register 2

LVDS_INT_TER[2:0]	Resistor value
000	no internal termination
001	300 Ω
010	180 Ω
011	110 Ω
100	150 Ω

Table 14. LVDS DDR output register 2 ...continued

LVDS_INT_TER[2:0]	Resistor value
101	100 $\Omega$
110	81 $\Omega$
111	60 $\Omega$

### 11.5.3 DAta Valid (DAV) output clock

A DAta Valid (DAV) output clock signal is provided that can be used to capture the data delivered by the ADC1412D. Detailed timing diagrams for CMOS and LVDS DDR modes are provided in [Figure 4](#) and [Figure 5](#) respectively. In LVDS DDR mode, it is highly recommended to shift ahead the DAV by 1 ns (bits DAVPHASE[2:0] = 0b100; see [Table 25](#)).

### 11.5.4 OuT-of-Range (OTR)

An out-of-range signal is provided on pin OTRA for ADC channel A and on pin OTRB for ADC channel B. The latency of OTRA/B is fourteen clock cycles. The OTR response can be speeded up by enabling Fast OTR (bit FASTOTR = logic 1; see [Table 30](#)). In this mode, the latency of OTRA/B is reduced to only four clock cycles (separately for each ADC channel). The Fast OTR detection threshold (below full-scale) can be programmed via bits FASTOTR\_DET.

Table 15. Fast OTR register

FASTOTR_DET[2:0]	Detection level
000	-20.56 dB
001	-16.12 dB
010	-11.02 dB
011	-7.82 dB
100	-5.49 dB
101	-3.66 dB
110	-2.14 dB
111	-0.86 dB

### 11.5.5 Digital offset

By default, the ADC1412D delivers output code that corresponds to the analog input. However, it is possible to add a digital offset to the output code via the SPI (bits DIG\_OFFSET; see [Table 26](#)).

### 11.5.6 Test patterns

For test purposes, the ADC1412D can be configured to transmit one of a number of predefined test patterns (via bits TESTPAT\_SEL; see [Table 27](#)). A custom test pattern can be defined by the user (TESTPAT\_USER; see [Table 28](#) and [Table 29](#)) and is selected when TESTPAT\_SEL = 101. The selected test pattern is transmitted regardless of the analog input.

### 11.5.7 Output codes versus input voltage

Table 16. Output codes

$V_{INAP} - V_{INAM}$ / $V_{INBP} - V_{INBM}$	Offset binary	Two's complement	OTRA/OTRB pin
< -1	00 0000 0000 0000	10 0000 0000 0000	1
-1	00 0000 0000 0000	10 0000 0000 0000	0
-0.9998779	00 0000 0000 0001	10 0000 0000 0001	0
-0.9997559	00 0000 0000 0010	10 0000 0000 0010	0
-0.9996338	00 0000 0000 0011	10 0000 0000 0011	0
-0.9995117	00 0000 0000 0100	10 0000 0000 0100	0
....	....	....	0
-0.0002441	01 1111 1111 1110	11 1111 1111 1110	0
-0.0001221	01 1111 1111 1111	11 1111 1111 1111	0
+0	<b>10 0000 0000 0000</b>	<b>00 0000 0000 0000</b>	0
+0.0001221	10 0000 0000 0001	00 0000 0000 0001	0
+0.0002441	10 0000 0000 0010	00 0000 0000 0010	0
....	....	....	0
+0.9995117	11 1111 1111 1011	01 1111 1111 1011	0
+0.9996338	11 1111 1111 1100	01 1111 1111 1100	0
+0.9997559	11 1111 1111 1101	01 1111 1111 1101	0
+0.9998779	11 1111 1111 1110	01 1111 1111 1110	0
+1	11 1111 1111 1111	01 1111 1111 1111	0
> +1	11 1111 1111 1111	01 1111 1111 1111	1

## 11.6 Serial Peripheral Interface (SPI)

### 11.6.1 Register description

The ADC1412D serial interface is a synchronous serial communications port that allows easy interfacing with many commonly used microprocessors. It provides access to the registers that control the operation of the chip.

This interface is configured as a 3-wire type (SDIO as bidirectional pin).

Pin SCLK is the serial clock input and  $\overline{CS}$  is the chip select pin.

Each read/write operation is initiated by a LOW level on  $\overline{CS}$ . A minimum of three bytes is transmitted (two instruction bytes and at least one data byte). The number of data bytes is determined by the value of bits W1 and W2 (see [Table 18](#)).

Table 17. Instruction bytes for the SPI

	MSB							LSB
Bit	7	6	5	4	3	2	1	0
Description	$R/\overline{W}$ [1]	W1[2]	W0[2]	A12	A11	A10	A9	A8
	A7	A6	A5	A4	A3	A2	A1	A0

[1] Bit  $R/\overline{W}$  indicates whether it is a read (1) or a write (0) operation.

[2] Bits W1 and W0 indicate the number of bytes to be transferred after the instruction byte (see [Table 18](#)).

**Table 18. Number of data bytes to be transferred after the instruction bytes**

W1	W0	Number of bytes transmitted
0	0	1 byte
0	1	2 bytes
1	0	3 bytes
1	1	4 bytes or more

Bits A12 to A0 indicate the address of the register being accessed. In the case of a multiple byte transfer, this address is the first register to be accessed. An address counter is increased to access subsequent addresses.

The steps for a data transfer:

1. A falling edge on  $\overline{CS}$  in combination with a rising edge on SCLK determine the start of communications.
2. The first phase is the transfer of the 2-byte instruction.
3. The second phase is the transfer of the data which can vary in length but is always a multiple of 8 bits. The MSB is always sent first (for instruction and data bytes).
4. A rising edge on  $\overline{CS}$  indicates the end of data transmission.

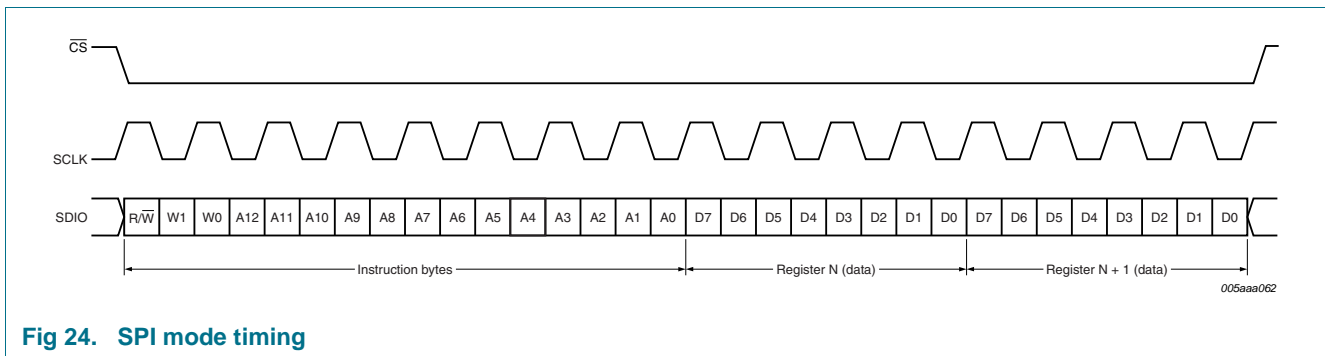

**Fig 24. SPI mode timing**

### 11.6.2 Default modes at start-up

During circuit initialization it does not matter which output data standard has been selected. At power-up, the device enters Pin control mode.

A falling edge on  $\overline{CS}$  triggers a transition to SPI control mode. When the ADC1412D enters SPI control mode, the output data standard (CMOS/LVDS DDR) is determined by the level on pin SDIO (see [Figure 25](#)). Once in SPI control mode, the output data standard can be changed via bit LVDS\_CMOS in [Table 24](#).

When the ADC1412D enters SPI control mode, the output data format (two's complement or offset binary) is determined by the level on pin SCLK (gray code can only be selected via the SPI). Once in SPI control mode, the output data format can be changed via bit DATA\_FORMAT in [Table 24](#).

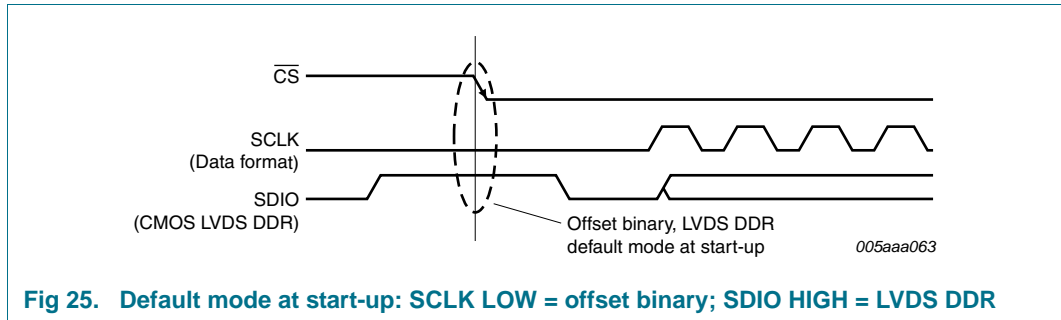

**Fig 25. Default mode at start-up: SCLK LOW = offset binary; SDIO HIGH = LVDS DDR**

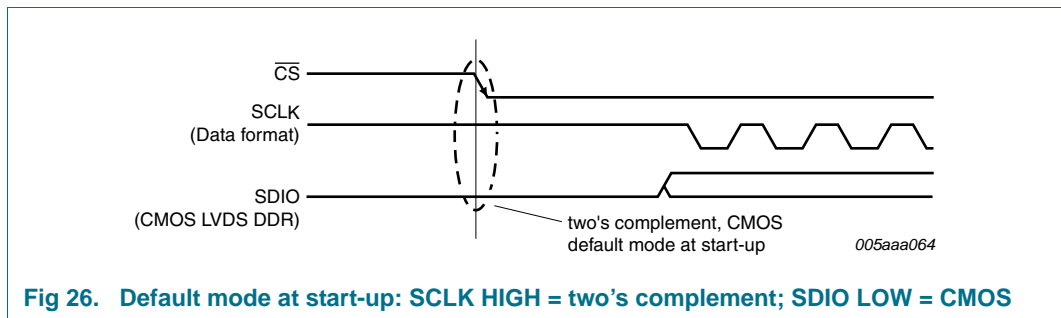

**Fig 26. Default mode at start-up: SCLK HIGH = two's complement; SDIO LOW = CMOS**

## 11.6.3 Register allocation map

Table 19. Register allocation map

Addr (Hex)	Register name	R/W	Bit definition								Default (Bin)
			Bit 7	Bit 6	Bit 5	Bit 4	Bit 3	Bit 2	Bit 1	Bit 0	
0003	Channel index	R/W	RESERVED[5:0]					ADCB	ADCA	11111 1111	
0005	Reset and operating mode	R/W	SW_RST	RESERVED[2:0]		-	-	OP_MODE[1:0]		0000 0000	
0006	Clock	R/W	-	-	-	SE_SEL	DIFF_SE	-	CLKDIV	DCS_EN	0000 0001
0008	Internal reference	R/W	-	-	-	-	INTREF_EN	INTREF[2:0]		0000 0000	
0011	Output data standard	R/W	-	-	-	LVDS_CMOS	OUTBUF	OUTBUS_SWAP	DATA_FORMAT[1:0]		0000 0000
0012	Output clock	R/W	-	-	-	-	DAVINV	DAVPHASE[2:0]		0000 1110	
0013	Offset	R/W	-	-	DIG_OFFSET[5:0]					0000 0000	
0014	Test pattern 1	R/W	-	-	-	-	-	TESTPAT_SEL[2:0]		0000 0000	
0015	Test pattern 2	R/W	TESTPAT_USER[13:6]								0000 0000
0016	Test pattern 3	R/W	TESTPAT_USER[5:0]					-	-	0000 0000	
0017	Fast OTR	R/W	-	-	-	-	FASTOTR	FASTOTR_DET[2:0]		0000 0000	
0020	CMOS output	R/W	-	-	-	-	DAV_DRV[1:0]		DATA_DRV[1:0]	0000 1110	
0021	LVDS DDR O/P 1	R/W	-	-	RESERVED	DAVI[1:0]		RESERVED	DATAI[1:0]		0000 0000
0022	LVDS DDR O/P 2	R/W	-	-	-	-	BIT_BYTE_WISE	LVDS_INT_TER[2:0]		0000 0000	

**Table 20. Channel index control register (address 0003h) bit description***Default values are highlighted.*

Bit	Symbol	Access	Value	Description
7 to 2	RESERVED[5:0]		<b>111111</b>	reserved
1	ADCB	R/W		next SPI command for ADC B
			0	ADC B not selected
			<b>1</b>	ADC B selected
0	ADCA	R/W		next SPI command for ADC A
			0	ADC A not selected
			<b>1</b>	ADC A selected

**Table 21. Reset and operating mode control register (address 0005h) bit description***Default values are highlighted.*

Bit	Symbol	Access	Value	Description
7	SW_RST	R/W		reset digital section
			<b>0</b>	no reset
			1	performs a reset on SPI registers
6 to 4	RESERVED[2:0]		<b>000</b>	reserved
3 to 2	-		00	not used
1 to 0	OP_MODE[1:0]	R/W		operating mode
			<b>00</b>	normal (Power-up)
			01	Power-down
			10	Sleep
			11	normal (Power-up)

**Table 22. Clock control register (address 0006h) bit description***Default values are highlighted.*

Bit	Symbol	Access	Value	Description
7 to 5	-		000	not used
4	SE_SEL	R/W		single-ended clock input pin select
			<b>0</b>	CLKM
			1	CLKP
3	DIFF_SE	R/W		differential/single-ended clock input select
			<b>0</b>	fully differential
			1	single-ended
2	RESERVED		<b>0</b>	reserved
1	CLKDIV	R/W		clock input divide by 2
			<b>0</b>	disabled
			1	enabled
0	DCS_EN	R/W		duty cycle stabilizer
			0	disabled
			<b>1</b>	enabled

**Table 23. Internal reference control register (address 0008h) bit description***Default values are highlighted.*

Bit	Symbol	Access	Value	Description
7 to 4	-		0000	not used
3	INTREF_EN	R/W		programmable internal reference enable
			<b>0</b>	disable
			1	active
2 to 0	INTREF[2:0]	R/W		programmable internal reference
			<b>000</b>	0 dB (FS = 2 V)
			001	-1 dB (FS = 1.78 V)
			010	-2 dB (FS = 1.59 V)
			011	-3 dB (FS = 1.42 V)
			100	-4 dB (FS = 1.26 V)
			101	-5 dB (FS = 1.12 V)
			110	-6 dB (FS = 1 V)
			111	reserved

**Table 24. Output data standard control register (address 0011h) bit description***Default values are highlighted.*

Bit	Symbol	Access	Value	Description
7 to 5	-		000	not used
4	LVDS_CMOS	R/W		output data standard: LVDS DDR or CMOS
			<b>0</b>	CMOS
			1	LVDS DDR
3	OUTBUF	R/W		output buffers enable
			<b>0</b>	output enabled
			1	output disabled (high Z)
2	OUTBUS_SWAP	R/W		output bus swap
			<b>0</b>	no swapping
			1	output bus is swapped (MSB becomes LSB, vice versa)
1 to 0	DATA_FORMAT[1:0]	R/W		output data format
			<b>00</b>	offset binary
			01	two's complement
			10	gray code
			11	offset binary



**Table 25. Output clock register (address 0012h) bit description***Default values are highlighted.*

Bit	Symbol	Access	Value	Description
7 to 4	-		0000	not used
3	DAVINV	R/W		output clock data valid (DAV) polarity
			0	normal
			1	inverted
2 to 0	DAVPHASE[2:0]	R/W		DAV phase select
			000	output clock shifted (ahead) by 3 ns
			001	output clock shifted (ahead) by 2.5 ns
			010	output clock shifted (ahead) by 2 ns
			011	output clock shifted (ahead) by 1.5 ns
			100	output clock shifted (ahead) by 1 ns
			101	output clock shifted (ahead) by 0.5 ns
			110	default value as defined in timing section
			111	output clock shifted (delayed) by 0.5 ns

**Table 26. Offset register (address 0013h) bit description***Default values are highlighted.*

Bit	Symbol	Access	Value	Description
7 to 6	-		00	not used
5 to 0	DIG_OFFSET[5:0]	R/W		digital offset adjustment
			011111	+31 LSB
			...	...
			000000	0
			...	...
			100000	-32 LSB

**Table 27. Test pattern 1 register (address 0014h) bit description***Default values are highlighted.*

Bit	Symbol	Access	Value	Description
7 to 3	-		00000	not used
2 to 0	TESTPAT_SEL[2:0]	R/W		digital test pattern select
			000	off
			001	mid scale
			010	-FS
			011	+FS
			100	toggle '1111..1111'/'0000..0000'
			101	custom test pattern
			110	'0101..0101'
			111	'1010..1010.'

**Table 28. Test pattern 2 register (address 0015h) bit description***Default values are highlighted.*

Bit	Symbol	Access	Value	Description
7 to 0	TESTPAT_USER[13:6]	R/W	<b>0000</b> <b>0000</b>	custom digital test pattern (bits 13 to 6)

**Table 29. Test pattern 3 register (address 0016h) bit description***Default values are highlighted.*

Bit	Symbol	Access	Value	Description
7 to 2	TESTPAT_USER[5:0]	R/W	<b>000000</b>	custom digital test pattern (bits 5 to 0)
1 to 0	-		00	not used

**Table 30. Fast OTR register (address 0017h) bit description***Default values are highlighted.*

Bit	Symbol	Access	Value	Description
7 to 4	-		0000	not used
3	FASTOTR	R/W		fast OuT-of-Range (OTR) detection
			<b>0</b>	disabled
			1	enabled
2 to 0	FASTOTR_DET[2:0]	R/W		set fast OTR detect level
			<b>000</b>	-20.56 dB
			001	-16.12 dB
			010	-11.02 dB
			011	-7.82 dB
			100	-5.49 dB
			101	-3.66 dB
			110	-2.14 dB
			111	-0.86 dB

**Table 31. CMOS output register (address 0020h) bit description***Default values are highlighted.*

Bit	Symbol	Access	Value	Description
7 to 4	-		0000	not used
3 to 2	DAV_DRV[1:0]	R/W		drive strength for DAV CMOS output buffer
			00	low
			01	medium
			10	high
			<b>11</b>	very high
1 to 0	DATA_DRV[1:0]	R/W		drive strength for data CMOS output buffer
			00	low
			01	medium
			<b>10</b>	high
			11	very high

**Table 32. LVDS DDR 1 output register (address 0021h) bit description***Default values are highlighted.*

Bit	Symbol	Access	Value	Description
7 to 6	-		000	not used
5	RESERVED	R/W	0	reserved
4 to 3	DAVI[1:0]	R/W		LVDS current for DAV LVDS buffer
			<b>00</b>	3.5 mA
			01	4.5 mA
			10	1.25 mA
			11	2.5 mA
2	RESERVED		0	reserved
1 to 0	DATAI[1:0]	R/W		LVDS current for data LVDS buffer
			<b>00</b>	3.5 mA
			01	4.5 mA
			10	1.25 mA
			11	2.5 mA

**Table 33. LVDS DDR 2 output register (address 0022h) bit description***Default values are highlighted.*

Bit	Symbol	Access	Value	Description
7 to 4	-		0000	not used
3	BIT_BYTE_WISE	R/W		DDR mode for LVDS output
			<b>0</b>	bit wise (even data bits output on DAV rising edge/odd data bits output on DAV falling edge)
			1	byte wise (MSB data bits output on DAV rising edge/LSB data bits output on DAV falling edge)
2 to 0	LVDS_INT_TER[2:0]	R/W		internal termination for LVDS buffer (DAV and data)
			<b>000</b>	no internal termination
			001	300 $\Omega$
			010	180 $\Omega$
			011	110 $\Omega$
			100	150 $\Omega$
			101	100 $\Omega$
			110	81 $\Omega$
			111	60 $\Omega$

12. Package outline

HVQFN64: plastic thermal enhanced very thin quad flat package; no leads; 64 terminals; body 9 x 9 x 0.85 mm

SOT804-3

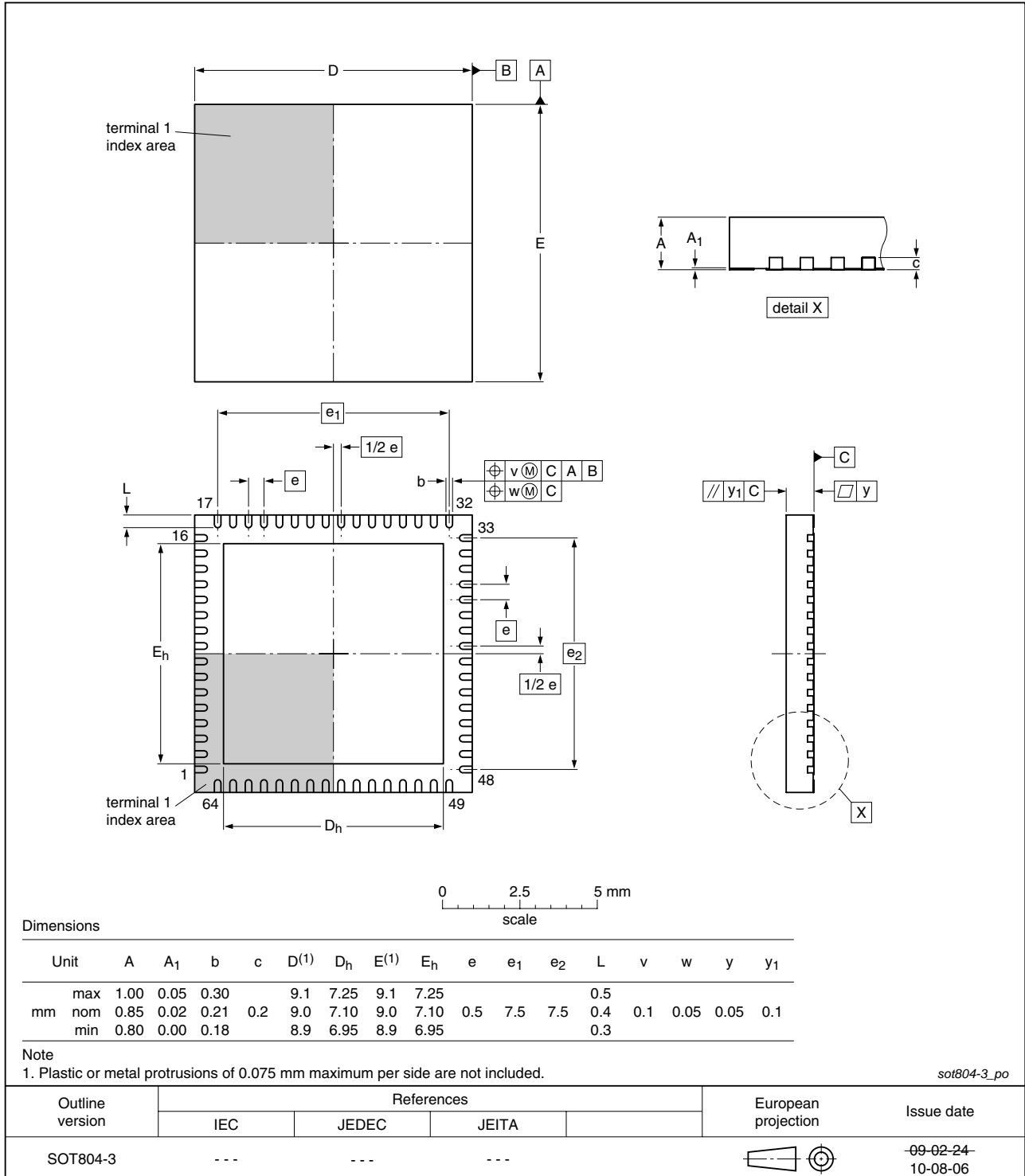

Fig 27. Package outline SOT804-3 (HVQFN64)

## 13. Revision history

Table 34. Revision history

Document ID	Release date	Data sheet status	Change notice	Supersedes
ADC1412D_SER v.3	20100806	Preliminary data sheet	-	ADC1412D065_080_105_125_2
Modifications:			<ul style="list-style-type: none"> <li>• Template upgraded to Rev 2.12.0 including revised legal information.</li> <li>• <a href="#">Figure 12 "Reference equivalent schematic"</a> has been updated</li> <li>• Dynamic characteristics table (<a href="#">Table 7</a>) has been updated.</li> </ul>	
ADC1412D065_080_105_125_2	20090604	Objective data sheet	-	ADC1412D065_080_105_125_1
ADC1412D065_080_105_125_1	20090528	Objective data sheet	-	-

## 14. Legal information

### 14.1 Data sheet status

Document status <sup>[1][2]</sup>	Product status <sup>[3]</sup>	Definition
Objective [short] data sheet	Development	This document contains data from the objective specification for product development.
Preliminary [short] data sheet	Qualification	This document contains data from the preliminary specification.
Product [short] data sheet	Production	This document contains the product specification.

[1] Please consult the most recently issued document before initiating or completing a design.

[2] The term 'short data sheet' is explained in section "Definitions".

[3] The product status of device(s) described in this document may have changed since this document was published and may differ in case of multiple devices. The latest product status information is available on the Internet at URL <http://www.nxp.com>.

### 14.2 Definitions

**Draft** — The document is a draft version only. The content is still under internal review and subject to formal approval, which may result in modifications or additions. NXP Semiconductors does not give any representations or warranties as to the accuracy or completeness of information included herein and shall have no liability for the consequences of use of such information.

**Short data sheet** — A short data sheet is an extract from a full data sheet with the same product type number(s) and title. A short data sheet is intended for quick reference only and should not be relied upon to contain detailed and full information. For detailed and full information see the relevant full data sheet, which is available on request via the local NXP Semiconductors sales office. In case of any inconsistency or conflict with the short data sheet, the full data sheet shall prevail.

**Product specification** — The information and data provided in a Product data sheet shall define the specification of the product as agreed between NXP Semiconductors and its customer, unless NXP Semiconductors and customer have explicitly agreed otherwise in writing. In no event however, shall an agreement be valid in which the NXP Semiconductors product is deemed to offer functions and qualities beyond those described in the Product data sheet.

### 14.3 Disclaimers

**Limited warranty and liability** — Information in this document is believed to be accurate and reliable. However, NXP Semiconductors does not give any representations or warranties, expressed or implied, as to the accuracy or completeness of such information and shall have no liability for the consequences of use of such information.

In no event shall NXP Semiconductors be liable for any indirect, incidental, punitive, special or consequential damages (including - without limitation - lost profits, lost savings, business interruption, costs related to the removal or replacement of any products or rework charges) whether or not such damages are based on tort (including negligence), warranty, breach of contract or any other legal theory.

Notwithstanding any damages that customer might incur for any reason whatsoever, NXP Semiconductors' aggregate and cumulative liability towards customer for the products described herein shall be limited in accordance with the *Terms and conditions of commercial sale* of NXP Semiconductors.

**Right to make changes** — NXP Semiconductors reserves the right to make changes to information published in this document, including without limitation specifications and product descriptions, at any time and without notice. This document supersedes and replaces all information supplied prior to the publication hereof.

**Suitability for use** — NXP Semiconductors products are not designed, authorized or warranted to be suitable for use in life support, life-critical or safety-critical systems or equipment, nor in applications where failure or

malfunction of an NXP Semiconductors product can reasonably be expected to result in personal injury, death or severe property or environmental damage. NXP Semiconductors accepts no liability for inclusion and/or use of NXP Semiconductors products in such equipment or applications and therefore such inclusion and/or use is at the customer's own risk.

**Applications** — Applications that are described herein for any of these products are for illustrative purposes only. NXP Semiconductors makes no representation or warranty that such applications will be suitable for the specified use without further testing or modification.

Customers are responsible for the design and operation of their applications and products using NXP Semiconductors products, and NXP Semiconductors accepts no liability for any assistance with applications or customer product design. It is customer's sole responsibility to determine whether the NXP Semiconductors product is suitable and fit for the customer's applications and products planned, as well as for the planned application and use of customer's third party customer(s). Customers should provide appropriate design and operating safeguards to minimize the risks associated with their applications and products.

NXP Semiconductors does not accept any liability related to any default, damage, costs or problem which is based on any weakness or default in the customer's applications or products, or the application or use by customer's third party customer(s). Customer is responsible for doing all necessary testing for the customer's applications and products using NXP Semiconductors products in order to avoid a default of the applications and the products or of the application or use by customer's third party customer(s). NXP does not accept any liability in this respect.

**Limiting values** — Stress above one or more limiting values (as defined in the Absolute Maximum Ratings System of IEC 60134) will cause permanent damage to the device. Limiting values are stress ratings only and (proper) operation of the device at these or any other conditions above those given in the Recommended operating conditions section (if present) or the Characteristics sections of this document is not warranted. Constant or repeated exposure to limiting values will permanently and irreversibly affect the quality and reliability of the device.

**Terms and conditions of commercial sale** — NXP Semiconductors products are sold subject to the general terms and conditions of commercial sale, as published at <http://www.nxp.com/profile/terms>, unless otherwise agreed in a valid written individual agreement. In case an individual agreement is concluded only the terms and conditions of the respective agreement shall apply. NXP Semiconductors hereby expressly objects to applying the customer's general terms and conditions with regard to the purchase of NXP Semiconductors products by customer.

**No offer to sell or license** — Nothing in this document may be interpreted or construed as an offer to sell products that is open for acceptance or the grant, conveyance or implication of any license under any copyrights, patents or other industrial or intellectual property rights.

**Export control** — This document as well as the item(s) described herein may be subject to export control regulations. Export might require a prior authorization from national authorities.

**Non-automotive qualified products** — Unless this data sheet expressly states that this specific NXP Semiconductors product is automotive qualified, the product is not suitable for automotive use. It is neither qualified nor tested in accordance with automotive testing or application requirements. NXP Semiconductors accepts no liability for inclusion and/or use of non-automotive qualified products in automotive equipment or applications.

In the event that customer uses the product for design-in and use in automotive applications to automotive specifications and standards, customer (a) shall use the product without NXP Semiconductors' warranty of the product for such automotive applications, use and specifications, and (b) whenever customer uses the product for automotive applications beyond

NXP Semiconductors' specifications such use shall be solely at customer's own risk, and (c) customer fully indemnifies NXP Semiconductors for any liability, damages or failed product claims resulting from customer design and use of the product for automotive applications beyond NXP Semiconductors' standard warranty and NXP Semiconductors' product specifications.

## 14.4 Trademarks

Notice: All referenced brands, product names, service names and trademarks are the property of their respective owners.

## 15. Contact information

For more information, please visit: <http://www.nxp.com>

For sales office addresses, please send an email to: [salesaddresses@nxp.com](mailto:salesaddresses@nxp.com)

## 16. Contents

<b>1</b>	<b>General description</b> . . . . .	<b>1</b>	11.5.7	Output codes versus input voltage. . . . .	27
<b>2</b>	<b>Features and benefits</b> . . . . .	<b>1</b>	11.6	Serial Peripheral Interface (SPI) . . . . .	27
<b>3</b>	<b>Applications</b> . . . . .	<b>1</b>	11.6.1	Register description . . . . .	27
<b>4</b>	<b>Ordering information</b> . . . . .	<b>2</b>	11.6.2	Default modes at start-up. . . . .	28
<b>5</b>	<b>Block diagram</b> . . . . .	<b>2</b>	11.6.3	Register allocation map . . . . .	30
<b>6</b>	<b>Pinning information</b> . . . . .	<b>3</b>	<b>12</b>	<b>Package outline</b> . . . . .	<b>36</b>
6.1	CMOS outputs selected . . . . .	3	<b>13</b>	<b>Revision history</b> . . . . .	<b>37</b>
6.1.1	Pinning . . . . .	3	<b>14</b>	<b>Legal information</b> . . . . .	<b>38</b>
6.1.2	Pin description . . . . .	3	14.1	Data sheet status . . . . .	38
6.2	LVDS/DDR outputs selected. . . . .	5	14.2	Definitions . . . . .	38
6.2.1	Pinning . . . . .	5	14.3	Disclaimers . . . . .	38
6.2.2	Pin description . . . . .	6	14.4	Trademarks . . . . .	39
<b>7</b>	<b>Limiting values</b> . . . . .	<b>7</b>	<b>15</b>	<b>Contact information</b> . . . . .	<b>39</b>
<b>8</b>	<b>Thermal characteristics</b> . . . . .	<b>7</b>	<b>16</b>	<b>Contents</b> . . . . .	<b>40</b>
<b>9</b>	<b>Static characteristics</b> . . . . .	<b>7</b>			
<b>10</b>	<b>Dynamic characteristics</b> . . . . .	<b>10</b>			
10.1	Dynamic characteristics . . . . .	10			
10.2	Clock and digital output timing . . . . .	11			
10.3	SPI timings . . . . .	14			
<b>11</b>	<b>Application information</b> . . . . .	<b>15</b>			
11.1	Device control . . . . .	15			
11.1.1	SPI and Pin control modes . . . . .	15			
11.1.2	Operating mode selection. . . . .	15			
11.1.3	Selecting the output data standard. . . . .	15			
11.1.4	Selecting the output data format. . . . .	16			
11.2	Analog inputs . . . . .	16			
11.2.1	Input stage . . . . .	16			
11.2.2	Anti-kickback circuitry . . . . .	16			
11.2.3	Transformer . . . . .	17			
11.3	System reference and power management . . . . .	18			
11.3.1	Internal/external references . . . . .	18			
11.3.2	Reference gain control . . . . .	21			
11.3.3	Common-mode output voltage ( $V_{O(cm)}$ ) . . . . .	21			
11.3.4	Biasing . . . . .	21			
11.4	Clock input . . . . .	22			
11.4.1	Drive modes . . . . .	22			
11.4.2	Equivalent input circuit . . . . .	23			
11.4.3	Duty cycle stabilizer . . . . .	23			
11.4.4	Clock input divider . . . . .	23			
11.5	Digital outputs . . . . .	24			
11.5.1	Digital output buffers: CMOS mode . . . . .	24			
11.5.2	Digital output buffers: LVDS DDR mode . . . . .	25			
11.5.3	DATA Valid (DAV) output clock . . . . .	26			
11.5.4	Out-of-Range (OTR) . . . . .	26			
11.5.5	Digital offset . . . . .	26			
11.5.6	Test patterns . . . . .	26			

Please be aware that important notices concerning this document and the product(s) described herein, have been included in section 'Legal information'.

© NXP B.V. 2010.

All rights reserved.

For more information, please visit: <http://www.nxp.com>

For sales office addresses, please send an email to: [salesaddresses@nxp.com](mailto:salesaddresses@nxp.com)

Date of release: 6 August 2010

Document identifier: ADC1412D\_SER