



PACIFIC DISPLAY DEVICES

LCD Component Data Sheet

Model Number: 16080-00

**160 x 80 Dot
Graphic LCD Assembly
With LC7981 Sanyo Graphic LCD Controller
EL Panel / LED Backlight Options**

CONTENTS

1.	GENERAL INFORMATION	
1.1	Product Overview	2
1.2	Part Options and Numbering System	2
1.3	Absolute Maximum Ratings	3
1.4	Circuit Block Diagram	3
1.5	Mechanical Characteristics	3
1.6	Input Signal Function	4
1.7	LCM Power, Contrast Control and Bias	4
1.8	LCD Dimensions	5
2.	ELECTRICAL / OPTICAL CHARACTERISTICS	
2.1	DC Electrical Characteristics	6
2.2	AC Electrical Characteristics	7
2.3	Optical Characteristics	8
2.4	LED Backlight Characteristics	10
2.5	EL Panel Backlight Characteristics	10
3.	LCD CONTROLLER CHARACTERISTICS	
3.1	LCD Controller Display and Control Functions (LC7981)	11
3.2	LCD Controller Character Code map	17
4.	RELIABILITY	18
5.	PRECAUTIONS FOR USING LCD MODULES	19

1. GENERAL INFORMATION

1.1 Product Overview

- 160 x 80 dot matrix LCD
- STN (Super Twisted Nematic) Technology
- LC7981 (or equivalent) Graphics Controller IC w/ 8K SRAM.
- Multiplex drive : 1/80 duty, 1/10 bias
- LCD Module Service Life: 100,000 hours minimum

1.2 Part Options and Numbering System

16080	-00	-SL	-F	-ST	-LED	-GY	-6	-V
-------	-----	-----	----	-----	------	-----	----	----

- **Custom Option Designator:**
 - Internal LC7981 Controller
- **Operating Mode:**
 - (-SL) STN Silver / Gray
 - (-GR) STN Green
 - (-BN) STN Blue Negative Image
 - (-FC) FSTN Black & White Image
- **Rear Polarizer Options:**
 - (-F) Transflective
 - (-M) Transmissive
 - (-R) Reflective (No Backlight)
- **Operating Temperature:**
 - (-ST) Standard (0 to +50 °C)
 - (-ET) Extended (-20 to +70 °C)
- **Backlight Options:**
 - (-LED) Array Lit LED Backlight
 - (-ELP) EL Panel Backlight
- **Backlight Coloration Options:**
 - (-WH) ELP – White
 - (-GY) LED - Green/Yellow
 - (-AM) LED - Amber
 - (-BG) ELP – Blue Green
- **Viewing Angle:**
 - (-6) 6 o'clock
 - (-12) 12 o'clock
- **Additional options:**
 - (-V) Internal -10V Vee Generator (Standard)
 - (-AF) Anti-Glare film on the front of the display
 - (-10.2) 10.2V LED backlight Option

1.3 Absolute Maximum Ratings

Parameter	Symbol	Min	Max	Unit
Supply voltage for logic	V_{DD}	-0.3	7.0	V
Supply voltage for LCD	$V_{DD} - V_0$	-0.3	10.0	V
Input voltage	V_I	-0.3	$V_{DD} + 0.3$	V
Standard Operating temperature	TOP (-ST)	0	50	°C
Standard Storage temperature	TST (-ST)	-10	60	°C
Extended Operating temperature	TOP (-ET)	-20	70	°C
Extended Storage temperature	TST (-ET)	-30	80	°C
Soldering Temp	Tsolder	260		°C

1.4 Circuit Block Diagram

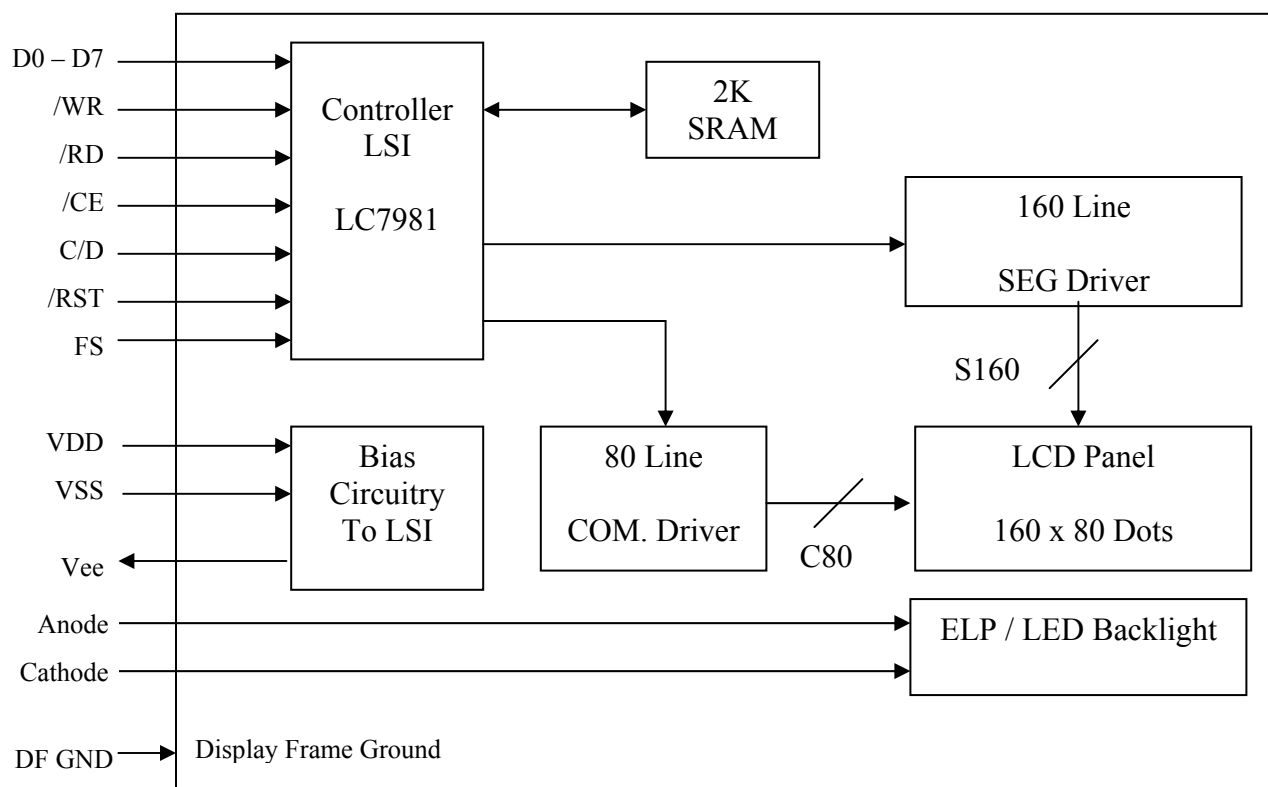

1.5 Mechanical Characteristics

Item	Contents	Unit
Module size (W×H×T)	100.0 x 54.0 x 15.3 Max (LED Backlight)	mm
	100.0 x 54.0 x 11.3 Max (No LED / ELP Backlight)	mm
Viewing area (W×H)	72.0 x 37.8	mm
Active area (W×H)	67.17 x 33.57	mm
Number of dots	160 x 80	dots
Dot size (W×H)	0.39 x 0.39	mm
Dot pitch (W×H)	0.42 x 0.42	mm

1.6 Input Signal Function

Pin No.	Symbol	Level	Description
1	VSS	0V	Ground
2	VDD	+5.0V	Supply voltage for logic
3	VO	--	Contrast bias voltage for LCD
4	RS	H/L	Register select: H:Instruction, L:Data
5	R/W	H/L	Controller read/write; H:Data Read, L:Data Write
6	E	H/L	Controller Access Enable
7-14	DB0-DB7	H/L	Bidirectional Data Bus Lines
15	/CS	H/L	Controller Chip Select: Active "L"
16	/RST	L	Reset: Active "L"
17	VEE	-10V	Negative Voltage Output (-10V)
18	NC	---	Not Used
19	LED-A	4.2V*	LED Backlight Anode
20	LED-K	0V	LED Backlight Cathode

Note:

1.7 LCM Power, Contrast Control and Bias

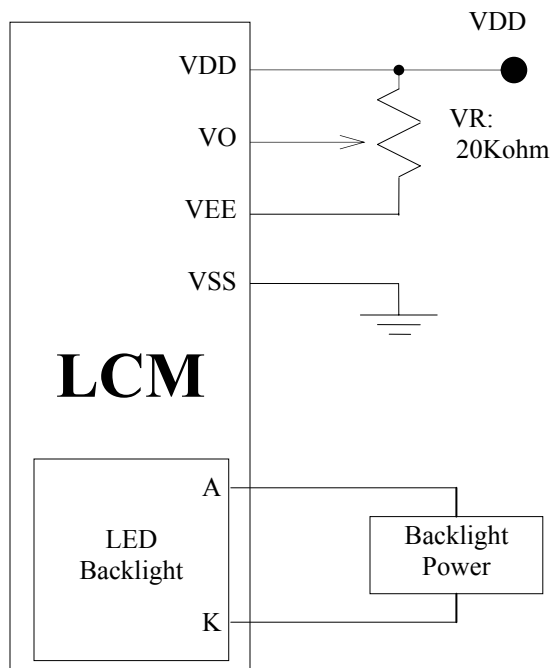

Note : DC-to-DC Converter Built In

1.8 LCM Dimensions

■ Module Dimensions

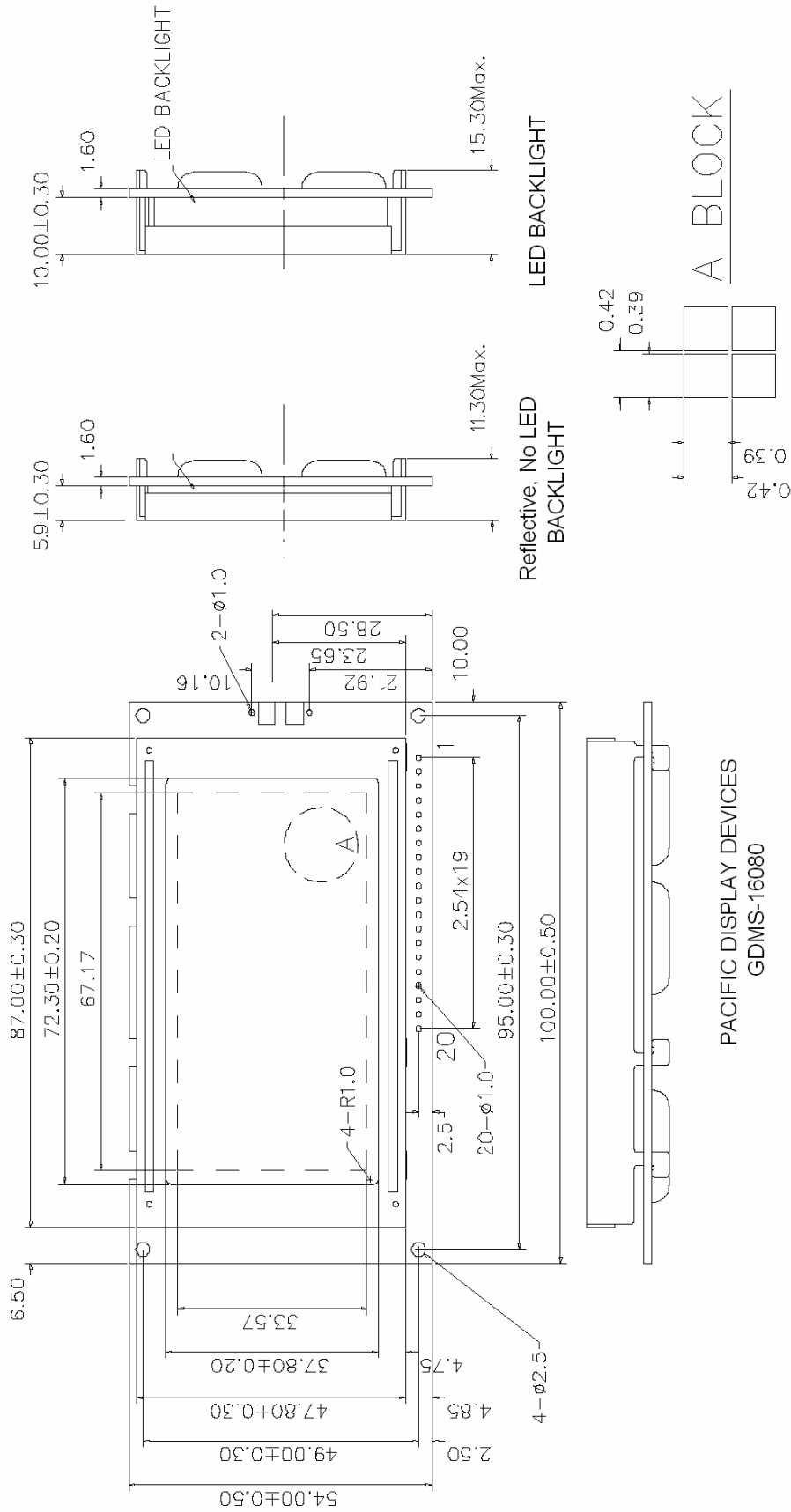

2. ELECTRICAL / OPTICAL CHARACTERISTICS

2.1 DC Electrical Characteristics ($V_{DD} = +5V \pm 10\%$, $V_{SS} = 0V$, $T_a = 25^\circ C$)

Parameter	Symbol	Condition	Min	Typ	Max	Unit
Supply voltage for logic	V_{DD}	---	4.75	---	5.25	V
Supply current for logic	I_{DD}	$V_{DD} = 5V$	---	15	22	mA
Operating voltage for LCD	$V_{DD} - V_{ee}$	0°C	--	12.5	--	V
		25°C	--	12.0	--	V
		50°C	--	11.4	--	V
Input voltage 'H' level	V_{IH}	---	$0.8 V_{DD}$	---	V_{DD}	V
Input voltage 'L' level	V_{IL}	---	0	---	$0.2 V_{DD}$	V

■ TIMING OF POWER SUPPLY

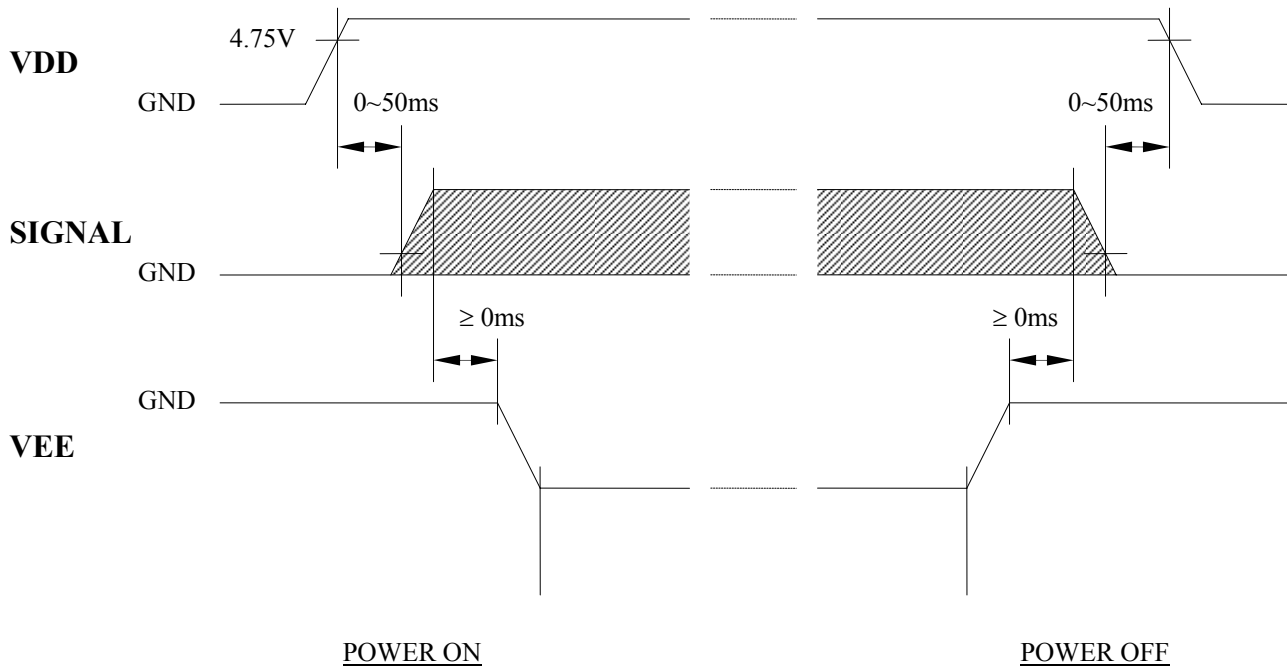

Note : The missing pixels may occur when the LCM is driven except above power supply timing sequence.

2.2 AC Electrical Characteristics

Sanyo LC-7981 Graphic Controller IC AC Waveform Interface

Parameter	Symbol	Min	Typ	Max	Unit
Enable Cycle Time	t_{CYC}	1.0	---	---	μs
Enable Pulse High Level Width	t_{WEH}	0.45	---	---	μs
Enable Pulse Low Level Width	t_{WEL}	0.45	---	---	μs
Enable Rise Time	t_{ER}	---	---	25	ns
Enable Fall Time	t_{EF}	---	---	25	ns
Setup Time	t_{AS}	90	---	---	ns
Data Setup Time	t_{DSW}	220	---	---	ns
Data Delay Time	t_{DDR}	---	---	140	ns
Data Hold Time	t_{DHW}	10	---	---	ns
Address Hold Time	t_{AH}	10	---	---	ns
Output Data Hold Time	t_{DH}	20	---	---	ns

Timing Chart

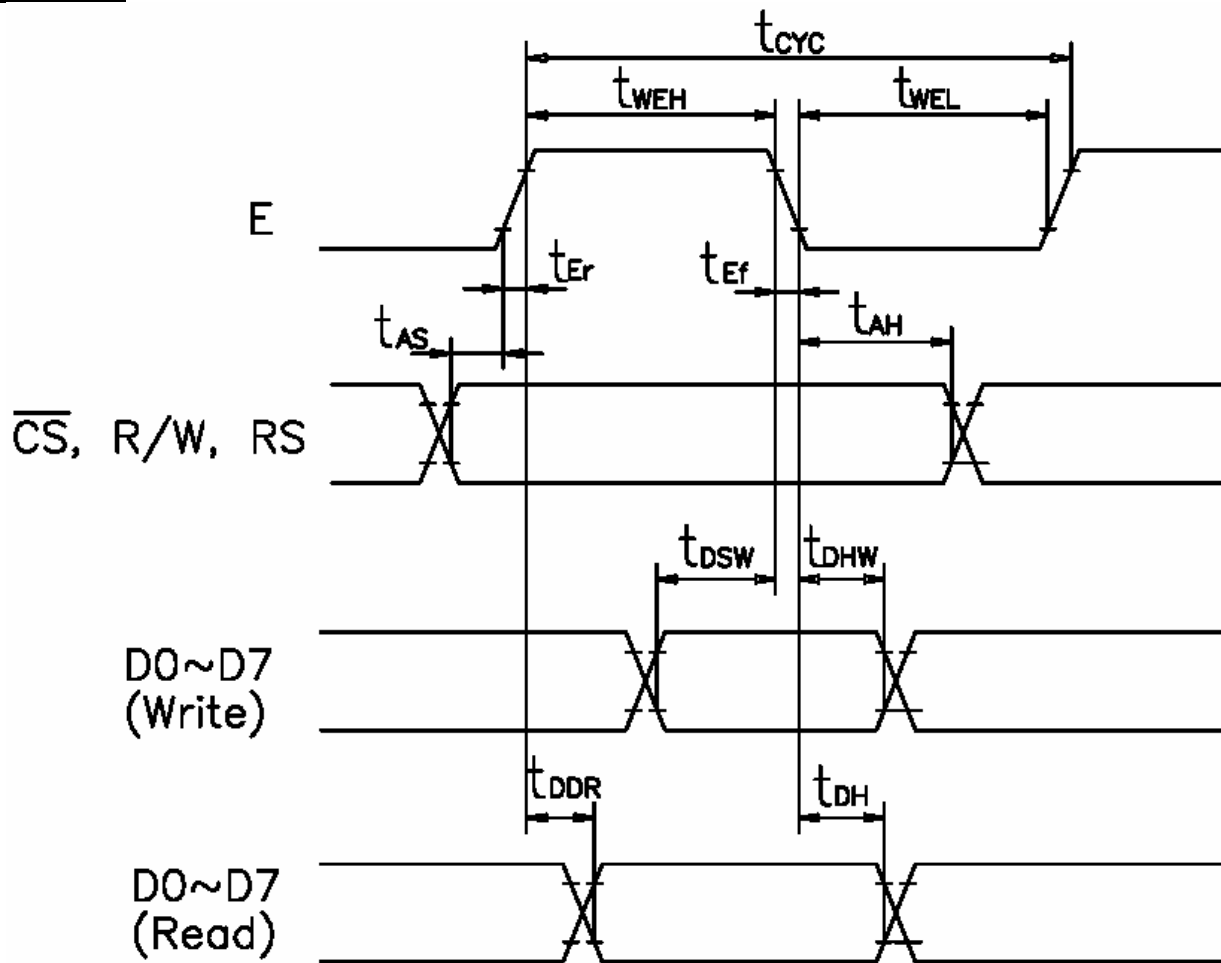

2.3 Optical Characteristics ($V_{OP} = 4.7V$, $T_a = 25^\circ C$)

Item	Symbol	Condition	Min	Typ	Max	Unit
Contrast ratio (STN)	Cr	$\theta=0^\circ$ $\phi=0^\circ$	---	3.7	---	---
Contrast ratio (FSTN)	Cr	$\theta=0^\circ$ $\phi=0^\circ$	---	9.2	---	---
Frame Frequency	f_{FRM}	---	32	64	150	Hz
Viewing angle range	θ_1	25°C	50	---	130	deg
	θ_2		---	40	---	deg
Response time	T_{on}	25°C	---	100	---	ms
	T_{off}		---	170	---	ms

Definition of angles ϕ and θ :

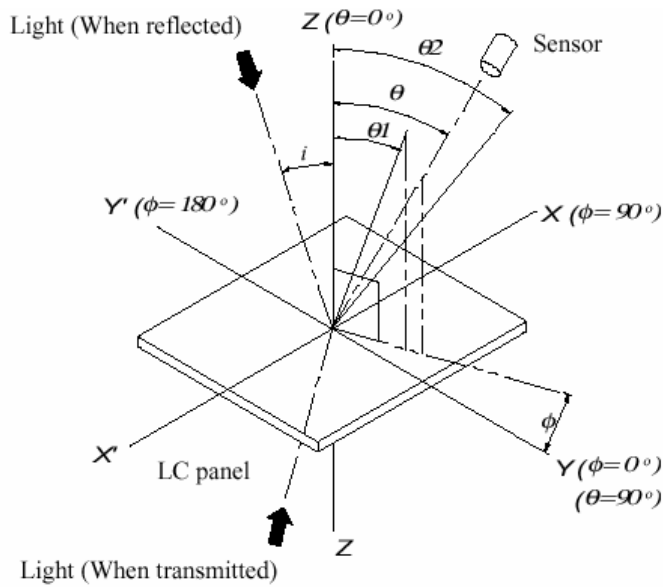

*Definition of contrast C

$$C = \frac{B1}{B2} = \frac{\text{Brightness of selected portion}}{\text{Brightness of unselected portion}}$$

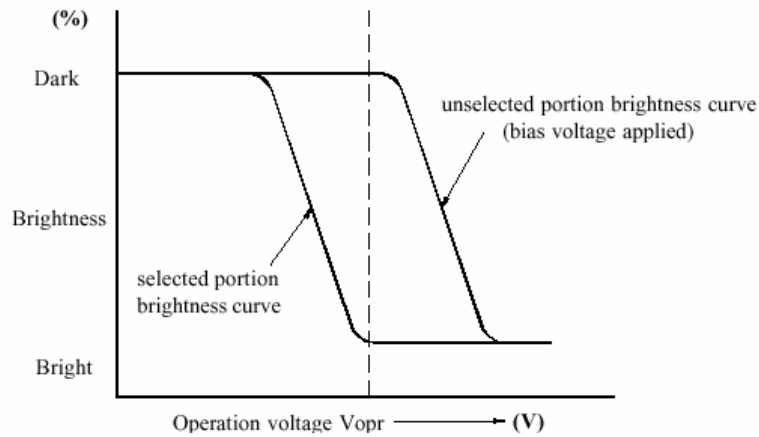

***Definition of viewing angles $\theta 1$ and $\theta 2$**

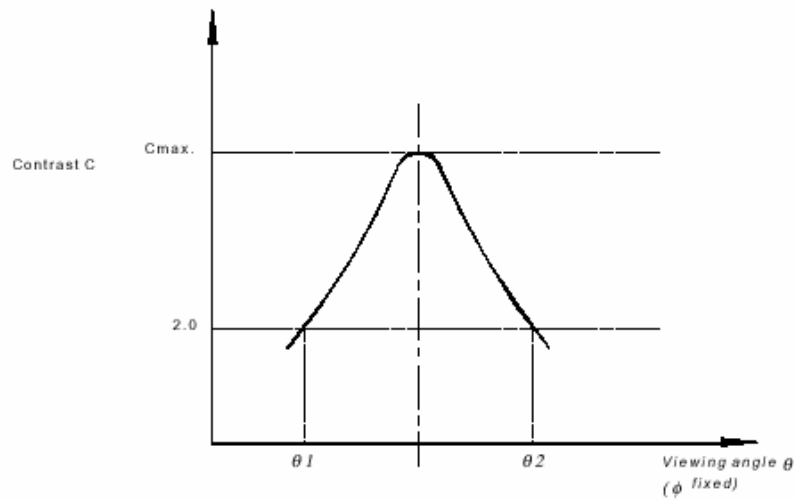

Note : Optimum vision with the naked eye and viewing angle θ at C_{max} above are not always the same.

***Definition of response time**

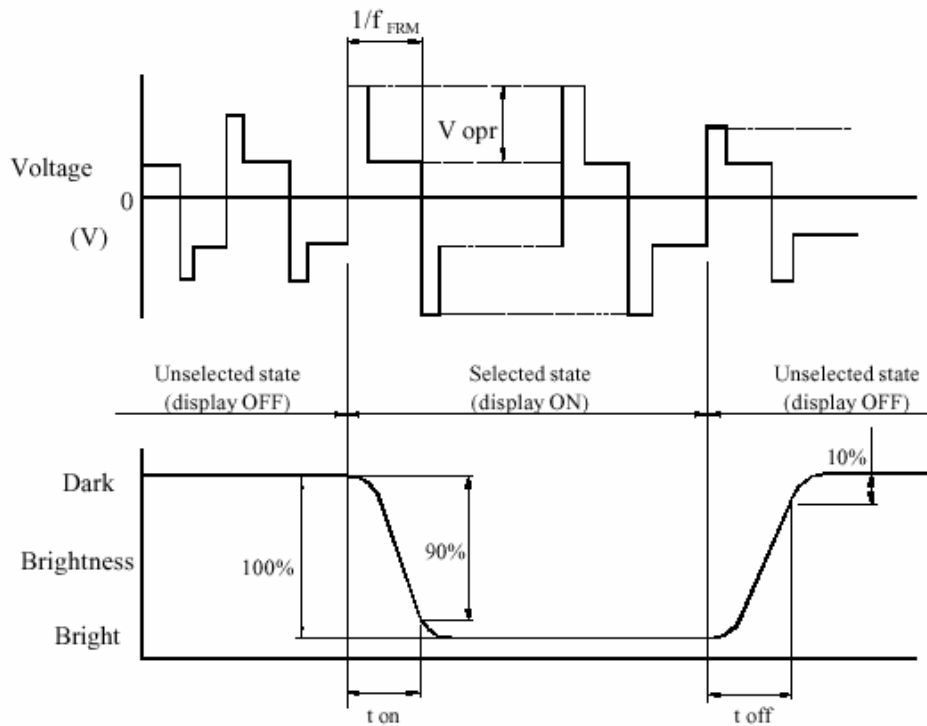

V_{opr} : Operating voltage (V)

t_{on} : Response time (rise) (ms)

f_{FRM} : Frame frequency (Hz)

t_{off} : Response time (fall) (ms)

2.4 LED Backlight Characteristics

■ Yellow-Green LED Operating Characteristics (4.1V - Array Lit)

Item	Symbol	Conditions	Standard			Unit
			Min.	Typ.	Max.	
Forward voltage	V_f	---	3.9	4.1	4.3	VDC
Forward Current	I_F	---	---	360	720	mA
Reverse Voltage	V_R	---	---	---	8	V
Peak Emission Wavelength	λ_P	If=360mA Yel/Grn	---	570	---	nm

■ Yellow-Green LED Operating Characteristics (10.2V - Array Lit)

Item	Symbol	Conditions	Standard			Unit
			Min.	Typ.	Max.	
Forward voltage	V_f	---	3.7	10.2	10.7	VDC
Forward Current	I_F	---	---	150	300	mA
Reverse Voltage	V_R	---	---	---	20	V
Peak Emission Wavelength	λ_P	If=150mA Yel/Grn	---	570	---	nm

■ Life

Item	Conditions	Standard		Unit
		Min.	Max.	
Life	Ta= 25 °C	100,000	---	hrs

2.5 EL Panel Backlight Characteristics (Blue-Green)

■ Blue-Green EL Panel Operating Characteristics:

Item	Conditions	Standard			Unit
		Min.	Typ.	Max.	
Current Consumption	100VAC RMS, 400Hz Ta: 25°C	---	10	20	mA
EL Drive Voltage	---	---	100	150	VAC RMS
EL Drive Frequency	---	---	400	1000	Hz
Operating Temperature	---	-35°C	---	+50°C	°C
Storage Temperature	---	-40°C	---	+60°C	°C
Luminance	100VAC RMS, 400Hz	48	60	---	cd/m ²
Luminance Half-Life	Ta: 25°C	3500	---	---	Hrs

*Note: half life is defined as Luminance being reduced by 50%

3. OPERATING PRINCIPALS AND METHODS

3.1 LCD Controller Display and Control Functions (Sanyo LC-7981 Controller)

Display is controlled by writing data into the instruction register and 13 data registers. The instruction register and the data register are distinguished by the RS signal. First, write 4-bit data in the instruction register when RS=1, then specify the code of the data register. Next, with RS=0, write 8-bit data in the data register, which executes the specified instruction.

A new instruction cannot be accepted while an old instruction is being executed. As the Busy flag is set under this condition, write an instruction only after reading the Busy flag and making sure that it is 0.

However, the next instruction can be executed without checking the busy flag when the maximum read cycle time or the write cycle time has been exceeded after execution of the previous data read instruction or the data write instruction. The busy flag does not change when data is written into the instruction register (RS=1). Therefore, the busy flag need not be checked immediately after writing data into the instruction register.

1) Mode control

Write code "00H" (in hexadecimal notation) in the instruction register and specify the mode control register.

Register	R/W	RS	DB7	DB6	DB5	DB4	DB3	DB2	DB1	DB0
Instruction register	0	1	0	0	0	0	0	0	0	0
Mode control register	0	0	0	0	MODE Data					

DB5	DB4	DB3	DB2	DB1	DB0	Cursor/blink	CG	Graphic/character display
1 / 0	1 / 0	0	0	0	0	Cursor OFF	Built-in CG	Character display
		0	1			Cursor ON		
		1	0			Cursor OFF character blink		
		1	1			Cursor blink		
		0	0		1	Cursor OFF	External CG	
		0	1			Cursor ON		
		1	0			Cursor OFF character blink		
		1	1			Cursor blink		
0	0	1	0	X		X	Graphic mode	
Display ON/OFF	Master/slave	Blink	Cursor	Mode	External/built-in CG			

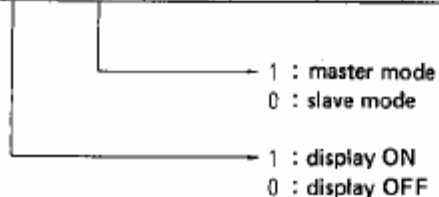

2) Setting the character pitch

Register	R/W	RS	DB7	DB6	DB5	DB4	DB3	DB2	DB1	DB0
Instruction register	0	1	0	0	0	0	0	0	0	1
Character pitch register	0	0	(Vp-1) Binary				0	(Hp-1) Binary		

Vp is the number of vertical dots per character. Determine Vp with the pitch between two vertically placed characters taken into consideration. This value is meaningful only in the character display mode: It is invalid in the graphic mode.

In character mode, Hp indicates the number of horizontal dots per character, from the leftmost part of one character to the leftmost part of the next. In the graphic mode, Hp indicates how many bits (or dots) from RAM appear in a 1-byte display.

Hp must take one of the following three values.

Hp	DB2	DB1	DB0	
6	1	0	1	Horizontal character pitch 6
7	1	1	0	7
8	1	1	1	8

3) Setting the number of characters

Register	R/W	RS	DB7	DB6	DB5	DB4	DB3	DB2	DB1	DB0
Instruction register	0	1	0	0	0	0	0	0	1	0
Character number register	0	0	(HN-1) Binary							

In the character display mode, HN indicates the number of characters in the horizontal direction. In the graphic mode, it indicates the number of bytes in the horizontal direction. The total number of dots positioned horizontally on the screen n is given by the formula

$$n = Hp \times HN.$$

Even numbers in the range 2 to 256 (decimal) can be set as HN.

4) Setting the time division number (display duty)

Register	R/W	RS	DB7	DB6	DB5	DB4	DB3	DB2	DB1	DB0
Instruction register	0	1	0	0	0	0	0	0	1	1
Time division register	0	0	(Nx-1) Binary							

Consequently, 1/Nx is the display duty.

Decimal numbers within the range 1 to 256 can be set as Nx.

5) Setting the cursor position

Register	R/W	RS	DB7	DB6	DB5	DB4	DB3	DB2	DB1	DB0
Instruction register	0	1	0	0	0	0	0	1	0	0
Cursor position register	0	0	0	0	0	0	(Cp-1) Binary			

In the character display mode, Cp indicates the line at which the cursor is displayed. For example, when Cp=8 (decimal) is specified, the cursor is displayed beneath the character of the 5 x 7 dot-font. The horizontal length of the cursor equals Hp (the horizontal character pitch). Decimal values in the range 1 to 16 can be assigned to Cp. When the value is less than the vertical character pitch Vp (Cp < Vp), display priority is given to the cursor (provided the cursor display is ON). The cursor is not displayed when Cp < Vp. The horizontal length of the cursor equals Hp.

6) Setting the display start lower address

Register	R/W	RS	DB7	DB6	DB5	DB4	DB3	DB2	DB1	DB0
Instruction register	0	1	0	0	0	0	1	0	0	0
Display start address register (lower byte)	0	0	(start address lower byte) binary							

7) Setting the display start upper address

Register	R/W	RS	DB7	DB6	DB5	DB4	DB3	DB2	DB1	DB0
Instruction register	0	1	0	0	0	0	1	0	0	1
Display start address register (upper byte)	0	0	(start address upper byte) binary							

This instruction writes the display start address value in the display start address register. The display start address is the RAM address at which data to be displayed at the leftmost position of the top line of the screen is stored. The start address consists of 16 bits (upper and lower).

8) Setting the cursor (lower) address (RAM read/write lower address)

Register	R/W	RS	DB7	DB6	DB5	DB4	DB3	DB2	DB1	DB0
Instruction register	0	1	0	0	0	0	1	0	1	0
Cursor address counter (lower byte)	0	0	(cursor address lower byte) binary							

9) Setting the cursor (upper) address (RAM read/write upper address)

Register	R/W	RS	DB7	DB6	DB5	DB4	DB3	DB2	DB1	DB0
Instruction register	0	1	0	0	0	0	1	0	1	1
Cursor address counter (upper byte)	0	0	(cursor address upper byte) binary							

This instruction writes the cursor address value in the cursor address counter. The cursor address indicates the address for exchanging display data and character codes with RAM. In other words, data at the address specified by the cursor address is read from or written into RAM. In character display, the cursor is displayed at the position specified by the cursor address.

The cursor address is divided into a lower address (8 bits) and an upper address (8 bits). It should be set in accordance with the following rules.

1	To rewrite (set) both lower and upper addresses:	First set the lower address, then the upper.
2	To rewrite the lower address:	Always reset the upper address after setting the lower address.
3	To rewrite the upper address only:	Set the upper address. It is necessary to reset the lower address.

The cursor address counter is a 16-bit up-counter with set/reset functions: when the Nth bit goes from 1 to 0, the count of the (N + 1)th bit increments by one. Accordingly, when the lower address is set so that the lower MSB (8th bit) changes from 1 to 0, the LSB (1st bit) of the upper counter must increment by one. When setting the cursor address, set the lower and upper addresses as a 2-byte continuous instruction.

10) Writing display data

Register	R/W	RS	DB7	DB6	DB5	DB4	DB3	DB2	DB1	DB0	
Instruction register	0	1	0	0	0	0	1	1	0	0	
RAM	0	0	MSB (pattern data, character code)							LSB	

Write code "0CH" in the instruction register. Then, write 8-bit data with RS=0, and the data is written into RAM as display data or character codes at the address specified by the cursor address counter. After writing, the count of the cursor address counter increments by 1.

11) Reading display data

Register	R/W	RS	DB7	DB6	DB5	DB4	DB3	DB2	DB1	DB0	
Instruction register	0	1	0	0	0	0	1	1	0	1	
RAM	1	0	MSB (pattern data, character code)							LSB	

Write "0DH" in the instruction register. Then, establish the read status with RS=0, and data in the RAM can be read. The procedure for reading data is as follows:

This instruction outputs the contents of the data output register to DB0 to 7, then transfers the RAM data indicated by the cursor address to the data output register. It then increments the cursor address by 1, which means that correct data cannot be read in the first read operation. The specified value is output in the second read operation. Accordingly, a dummy read operation must be performed once when reading data after setting the cursor address.

12) Bit clear

Register	R/W	RS	DB7	DB6	DB5	DB4	DB3	DB2	DB1	DB0
Instruction register	0	1	0	0	0	0	1	1	1	0
Bit clear	0	0	0	0	0	0	0	(NB-1) Binary		

13) Bit set

Register	R/W	RS	DB7	DB6	DB5	DB4	DB3	DB2	DB1	DB0
Instruction register	0	1	0	0	0	0	1	1	1	1
Bit set	0	0	0	0	0	0	0	(NB-1) Binary		

As the bit-clear or bit-set instruction, 1 bit of a 1 byte of data in display RAM is set to 0 or 1. The bit specified by N_B is set to 0 for the bit-clear instruction and 1 for the bit-set instruction. The RAM address is specified by the cursor address, which is automatically incremented by 1 at the completion of the instruction. NB is a value in the range from 1 to 8. The LSB is indicated by $N_B=1$, and the MSB by $N_B=8$.

14) Reading the BUSY flag

Register	R/W	RS	DB7	DB6	DB5	DB4	DB3	DB2	DB1	DB0
Busy flag	1	1	1 / 0	*						

The busy flag is output to DB7 when read mode is established with RS=1. The busy flag is set to 1 while any of the instructions 1) through 13) is being executed. It is set to 0 at the completion of the execution, allowing the next instruction to be accepted. No other instruction can be accepted when the busy flag is 1. Accordingly, before writing an instruction and data, it is necessary to ensure that the busy flag is 0. However, the next instruction can be executed without checking the busy flag when the maximum read cycle time or the write cycle time has been exceeded after execution of the previous data read instruction or the data write instruction.

The busy flag does not change when data is written into the instruction register (RS=1). Therefore, the busy flag need not be checked immediately after writing data into the instruction register.

Specification of the instruction register is unnecessary to read the busy flag.

The relation between the LCD panel display and Hp, HN, Vp, Cp, and Nx.

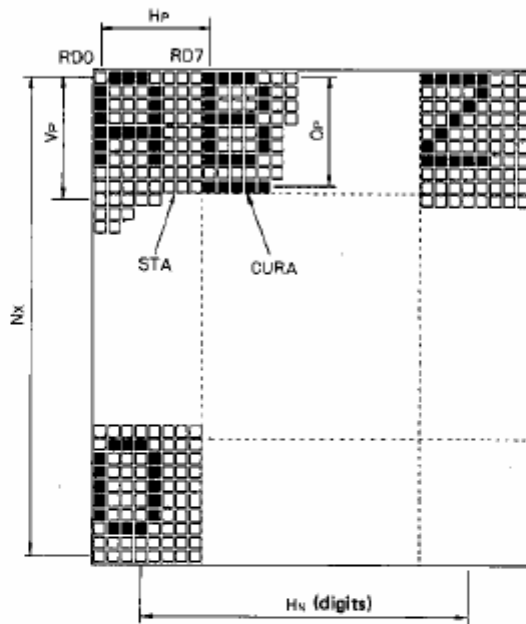

Symbol	Description	Contents	Value
Hp	Horizontal character pitch	Character pitch in the horizontal direction	6 to 8 dots
HN	Number of characters in the horizontal direction	Number of characters (digits) per horizontal line or the number of words per line (graphic)	Even digits in the range 2 to 256
Vp	Vertical character pitch	Character pitch in the vertical direction	1 to 16 dots
Cp	Cursor position	The line number at which the cursor is to be displayed	1 to 16 lines
Nx	Number of lines in the vertical direction	Display duty	1 to 256 lines

Note)

When the number of vertical dots on the screen is m and that of horizontal dots is n,

$$1/m = 1/Nx = \text{display duty}$$

$$n = Hp \times HN$$

$$m/Vp = \text{number of display lines}$$

$$Cp \leq Vp$$

3.2 LCD Controller Character Code Map

Upper 4 bits Lower 4 bits	0000	0001	0010	0011	0100	0101	0110	0111	1000	1001	1010	1011	1100	1101	1110	1111
0000	CG RAM (1)			0	1	2	3	4				5	6	7	8	9
0001	CG RAM (2)		!	@	A	B	C	D			E	F	G	H	I	J
0010	CG RAM (3)		"	#	Z	R	B	r			7	8	9	0	1	2
0011	CG RAM (4)		*	3	C	S	c	s			4	5	6	7	8	9
0100	CG RAM (5)		\$	4	D	T	d	t			6	7	8	9	0	1
0101	CG RAM (6)		%	5	E	U	e	u			7	8	9	0	1	2
0110	CG RAM (7)		&	6	F	V	f	v			8	9	0	1	2	3
0111	CG RAM (8)		'	7	G	W	g	w			9	0	1	2	3	4
1000	CG RAM (1)		(8	H	X	h	x			0	1	2	3	4	5
1001	CG RAM (2))	9	I	Y	i	y			1	2	3	4	5	6
1010	CG RAM (3)		*	0	J	Z	j	z			2	3	4	5	6	7
1011	CG RAM (4)		+	1	K		k				3	4	5	6	7	8
1100	CG RAM (5)		,	<	L		l				4	5	6	7	8	9
1101	CG RAM (6)		-	=	M		m				5	6	7	8	9	0
1110	CG RAM (7)		.	>	N		n				6	7	8	9	0	1
1111	CG RAM (8)		/	?	O		o				7	8	9	0	1	2

5. PRECAUTIONS FOR USING LCD MODULES

Installing LCD Modules

The hole in the printed circuit board is used to fix LCM as shown in the picture below. Attend to the following items when installing the LCM.

- 1) Cover the surface with a transparent protective plate to protect the polarizer and LC cell.

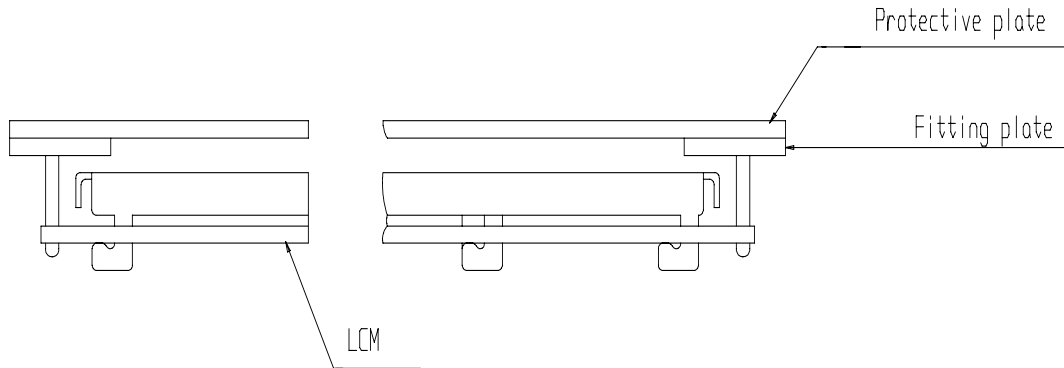

- 2) When assembling the LCM into other equipment, the spacer to the bit between the LCM and the fitting plate should have enough height to avoid causing stress to the module surface, refer to the individual specifications for measurements. The measurement tolerance should be ± 0.1 mm.

Precaution for Handling LCD Modules

Since LCM has been assembled and adjusted with a high degree of precision, avoid applying excessive shocks to the module or making any alterations or modifications to it.

- 1) Cover the surface with a transparent protective plate to protect the polarizer and LC cell.
- 2) Do not alter, modify or change the shape of the tab on the metal frame.
- 3) Do not make extra holes on the printed circuit board, modify its shape or change the positions of components to be attached.
- 4) Do not damage or modify the pattern writing on the printed circuit board.
- 5) Absolutely do not modify the zebra rubber strip (conductive rubber) or heat seal connector.
- 6) Except for soldering the interface, do not make any alterations or modifications with a soldering iron.
- 7) Do not drop, bend or twist LCM.

Electro-Static Discharge Control

Since this module uses a CMOS LSI, the same careful attention should be paid to electrostatic discharge as for an ordinary CMOS IC.

- 1) Make certain that you are grounded when handling LCM.
- 2) Before remove LCM from its packing case or incorporating it into a set, be sure the module and your body have the same electric potential.
- 3) When soldering the terminal of LCM, make certain the AC power source for the soldering iron does not leak.
- 4) When using an electric screwdriver to attach LCM, the screwdriver should be of ground potentiality to minimize as much as possible any transmission of electromagnetic waves produced sparks coming from the commutator of the motor.
- 5) As far as possible make the electric potential of your work clothes and that of the work bench the ground potential.
- 6) To reduce the generation of static electricity be careful that the air in the work is not too dried. A relative humidity of 50%-60% is recommended.

Precaution for soldering to the LCM

- 1) Observe the following when soldering lead wire, connector cable and etc. to the LCM.
 - a) Soldering iron temperature : $280^{\circ}\text{C} \pm 10^{\circ}\text{C}$.
 - b) Soldering time : 3-4 sec.
- 2) Solder : eutectic solder.

- 3) If soldering flux is used, be sure to remove any remaining flux after finishing to soldering operation. (This does not apply in the case of a non-halogen type of flux.) It is recommended that you protect the LCD surface with a cover during soldering to prevent any damage due to flux spatters.
- 4) When soldering the electroluminescent panel and PC board, the panel and board should not be detached more than three times. This maximum number is determined by the temperature and time conditions mentioned above, though there may be some variance depending on the temperature of the soldering iron.
- 5) When remove the electroluminescent panel from the PC board, be sure the solder has completely melted, the soldered pad on the PC board could be damaged.

Precautions for Operation

- 1) Viewing angle varies with the change of liquid crystal driving voltage (VO). Adjust VO to show the best contrast.
- 2) Driving the LCD in the voltage above the limit shortens its life.
- 3) Response time is greatly delayed at temperature below the operating temperature range. However, this does not mean the LCD will be out of the order. It will recover when it returns to the specified temperature range.
- 4) If the display area is pushed hard during operation, the display will become abnormal. However, it will return to normal if it is turned off and then back on.
- 5) Condensation on terminals can cause an electrochemical reaction disrupting the terminal circuit. Therefore, it must be used under the relative condition of 40°C , 50% RH.
- 6) When turning the power on, input each signal after the positive/negative voltage becomes stable.

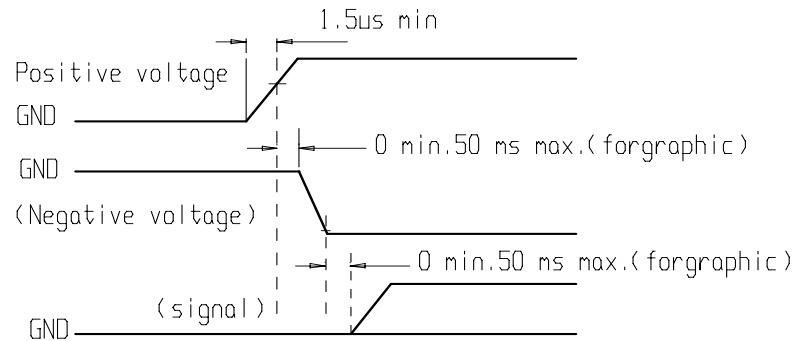

Safety

- If the LCD panel breaks, be careful not to get the liquid crystal in your mouth. If the liquid crystal touches your skin or clothes, wash it off immediately using soap and plenty of water.

Handling

- The display panel is made of glass. Do not subject it to a mechanical shock by dropping it or impact.
- If the display panel is damaged and the liquid crystal substance leaks out, be sure not to get any in your mouth. If the substance contacts your skin or clothes, wash it off using soap and water.
- Do not apply excessive force to the display surface or the adjoining areas since this may cause the color tone to vary.
- The polarizer covering the display surface of the LCD module is soft and easily scratched. Handle this polarizer carefully.
- If the display surface becomes contaminated, breathe on the surface and gently wipe it with a soft dry cloth. If it is heavily contaminated, moisten cloth with one of the following solvents :
 - Isopropyl alcohol
 - Ethyl alcohol
- Solvents other than those above-mentioned may damage the polarizer. Especially, do not use the following.
 - Water
 - Ketone
 - Aromatic solvents
- Exercise care to minimize corrosion of the electrode. Corrosion of the electrodes is accelerated by water droplets, moisture condensation or a current flow in a high-humidity environment.
- Install the LCD Module by using the mounting holes. When mounting the LCD module make sure it is free of twisting, warping and distortion. In particular, do not forcibly pull or bend the I/O cable or the backlight cable.
- Do not attempt to disassemble or process the LCD module.
- NC terminal should be open. Do not connect anything.
- If the logic circuit power is off, do not apply the input signals.

- To prevent destruction of the elements by static electricity, be careful to maintain an optimum work environment.
 - Be sure to ground the body when handling the LCD modules.
 - Tools required for assembling, such as soldering irons, must be properly grounded.
 - To reduce the amount of static electricity generated, do not conduct assembling and other work under dry conditions.
 - The LCD module is coated with a film to protect the display surface. Exercise care when peeling off this protective film since static electricity may be generated.

Storage

- When storing the LCD modules, avoid exposure to direct sunlight or to the light of fluorescent lamps
- Store the module in a dark place where the temperature is $25^{\circ}\text{C} \pm 10^{\circ}\text{C}$ and the humidity below 65% RH.
- Do not store the module near organic solvents or corrosive gases.
- Do not crush, shake, or jolt the module (including accessories).

Cleaning

- Do not wipe the polarizing plate with a dry cloth, as it may scratch the surface.
- Wipe the module gently with soft cloth soaked with a petroleum benzene.
- Do not use ketonic solvents (ketone and acetone) or aromatic solvents (toluene and xylene), as they may damage the polarizing plate.

Others:

- Liquid crystals solidify under low temperature (below the storage temperature range) leading to defective orientation or the generation of air bubbles (black or white). Air bubbles may also be generated if the module is subject to a low temperature.
- If the LCD modules have been operating for a long time showing the same display patterns, the display patterns may remain on the screen as ghost images and a slight contrast irregularity may also appear. A normal operating status can be regained by suspending use for some time. It should be noted that this phenomenon does not adversely affect performance reliability.
- To minimize the performance degradation of the LCD modules resulting from destruction caused by static electricity etc., exercise care to avoid holding the following sections when handling the modules.
 - Exposed area of the printed circuit board.
 - Terminal electrode sections.