

### Applications

- IEEE802.11b DSSS WLAN
- IEEE802.11g,n OFDM WLAN
- High Power Wireless Networking Products

### Features

- Dual Mode IEEE802.11b, IEEE802.11g, IEEE802.11n
- 23 dBm, EVM = 3%, 802.11g, OFDM 54 Mbps
- 26 dBm, ACPR < -32 dBc, 802.11b
- Integrated PA, Input Match, 2.8V reference voltage generator
- Integrated Temperature Compensated, Positive Slope Power Detector
- Pb-free, RoHS compliant and Halogen-free
- 3 mm x 3 mm x 0.6 mm QFN, MSL 3

### Product Description

The SE2565T is a high power 802.11bgn WLAN power amplifier module providing the functionality of the power amplifier, power detector, reference voltage generator and input match.

The SE2565T is designed for ease of use and maximum flexibility, with an integrated input match, and external output match to adjust the load line for either 3.3V, 23dBm operation.

The SE2565T includes a temperature compensated transmit power detector with over 20 dB of dynamic range and <1.2dB variation under 3:1 mismatch at the antenna.

The SE2565T includes a digital enable control due to an integrated reference voltage generator. The power ramp rise/fall time is 0.5  $\mu$ s typical.

### Ordering Information

Part No.	Package	Remark
SE2565T	16 pin QFN	Samples
SE2565T-R	16 pin QFN	Tape & Reel
SE2565T-EK1	N/A	Evaluation kit

### Functional Block Diagram

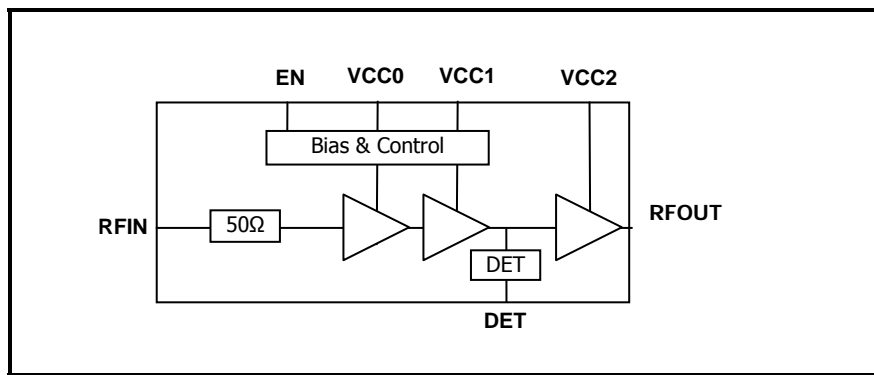

Figure 1: Functional Block Diagram

<http://www.sige.com>

Email: [sales@sige.com](mailto:sales@sige.com)

**Customer Service Locations:**

North America:  
1050 Morrison Drive, Suite 100  
Ottawa ON K2H 8K7 Canada

Phone: +1 613 820 9244  
Fax: +1 613 820 4933

Hong Kong  
Phone: +852 3428 7222  
Fax: +852 3579 5450

San Diego  
Phone: +1 858 668 3541 (ext. 226)  
Fax: +1 858 668 3546

United Kingdom  
Phone: +44 1279 464217  
Fax: +44 1279 464201

Product Preview

The datasheet contains information from the product concept specification. SiGe Semiconductor, Inc. reserves the right to change information at any time without notification.

Preliminary Information

The datasheet contains information from the design target specification. SiGe Semiconductor, Inc. reserves the right to change information at any time without notification.

Production testing may not include testing of all parameters.

Information furnished is believed to be accurate and reliable and is provided on an "as is" basis. SiGe Semiconductor, Inc. assumes no responsibility or liability for the direct or indirect consequences of use of such information nor for any infringement of patents or other rights of third parties, which may result from its use. No license or indemnity is granted by implication or otherwise under any patent or other intellectual property rights of SiGe Semiconductor, Inc. or third parties. Specifications mentioned in this publication are subject to change without notice. This publication supersedes and replaces all information previously supplied. SiGe Semiconductor, Inc. products are NOT authorized for use in implantation or life support applications or systems without express written approval from SiGe Semiconductor, Inc.

Copyright 2009 SiGe Semiconductor, Inc.  
All Rights Reserved

