

5.0x7.0mm Surface Mount LVDS Clock Oscillator Series



2111 Comprehensive Drive
Aurora, Illinois 60505
Phone: 630-851-4722
Fax: 630-851-5040
www.conwin.com
US Headquarters:
630-851-4722
European Headquarters:
+353-61-472221

Description

The Connor-Winfield LMxxx - Series are 5x7.0mm Surface Mount, LVDS, Fixed Frequency Crystal Controlled Oscillator (XO). Through the use of multiplication, the LMxxx - Series are designed for applications requiring tight frequency stability, wide temperature range and low jitter. Operating at 2.5V or 3.3V supply voltage, the LMxxx - Series provides LVDS Differential Outputs with enable / disable function. The surface mount package is designed for high-density mounting and is optimum for mass production.



Features:

Model LMxxx - Series

5.0 x7.0mm Surface Mount Package
2.5V or 3.3V Operation
LVDS Output Logic
Frequency Stabilities Available:
LM14x / LM34x / LM44x: +/-20ppm
LM11x / LM31x / LM41x: +/-25ppm
LM12x / LM22x / LM32x / LM42x: +/-50ppm
LM13x / LM23x / LM33x / LM43x: +/-100ppm
Temperature Ranges Available:
LM1xx Series: 0 to 70°C
LM2xx Series: -40 to 85°C
LM3xx Series: 0 to 85°C
LM4xx Series: -20 to 70°C
Low Jitter <1ps RMS
Tri-State Enable/Disable
Tape and Reel Packaging
RoHS Compliant / Lead Free ✓RoHS

Model Specifications

Absolute Maximum Ratings

Table 1.0

Parameter	Units	Minimum	Nominal	Maximum	Units	Note
Storage Temperature		-55	-	125	°C	
Supply Voltage	(Vcc)	-0.5	-	4.6	Vdc	
Input Voltage		-0.5	-	Vcc+0.5	Vdc	

Operating Specifications

Table 2.0

Parameter	Minimum	Nominal	Maximum	Units	Note
Center Frequency	(Fo)	100	-	670	MHz
Total Frequency Tolerance	(See Table 9 for full part number)				
Model LMx4x (See Table 9)	-20	-	20	ppm	1
Model LMx1x (See Table 9)	-25	-	25	ppm	1
Model LMx2x (See Table 9)	-50	-	50	ppm	1
Model LMx3x (See Table 9)	-100	-	100	ppm	1
Operating Temperature Range					
Model LM1xx (See Table 9)	0	-	70	°C	
Model LM4xx (See Table 9)	-20	-	70	°C	
Model LM3xx (See Table 9)	0	-	85	°C	
Model LM2xx (See Table 9)	-40	-	85	°C	
Supply Voltage	(Vcc)				
Model LMxx2 (See Table 9)	2.375	2.500	2.625	Vdc	
Model LMxx3 (See Table 9)	3.135	3.3	3.465	Vdc	
Supply Current	(Icc)	-	60	90	mA
Period Jitter		-	3	5	ps RMS
Phase Jitter- BW=12KHz to 20MHz		-	0.6	1.0	ps RMS
SSB Phase Noise at 10Hz offset		-	-40	-	dBc/Hz
SSB Phase Noise at 100Hz offset		-	-75	-	dBc/Hz
SSB Phase Noise at 1KHz offset		-	-95	-	dBc/Hz
SSB Phase Noise at 10KHz offset		-	-110	-	dBc/Hz
SSB Phase Noise at 100KHz offset		-	-115	-	dBc/Hz
Sub-Harmonics		-	-60	-50	dBc

Input Characteristics

Table 3.0

Parameter	Minimum	Nominal	Maximum	Units	Note
Disable Input Voltage (Low)	(Vil)	-	-	0.3Vcc	Vdc 2
Enable Input Voltage (High)	(Vih)	0.7Vcc	-	-	Vdc 2

LVDS Output Characteristics

Table 4.0

Parameter	Minimum	Nominal	Maximum	Units	Note
LOAD		-	-	100	Ohms
Output Differential Voltage	(Vod)	250	-	450	mV 3
Output Swing (Differential Output peak to peak)	(Vopp)	500	700	900	mV
Duty Cycle measured at 50%		45	50	55	% 4
Differential Rise / Fall Time 20% to 80%		-	0.3	0.7	ns

Notes

- 1) Includes initial tolerance, deviation over temperature, supply and load variations, shock, vibration and 20 years aging.
- 2) When the oscillator is disabled, the outputs are at High Impedance. Output is enabled with no connection on pad 1.
- 3) Vod measured with 100 ohm resistor between the true output and the complementary output.
- 4) Duty Cycle measured at 50% of output swing.



Bulletin	Ds030
Page	1 of 2
Revision	P01
Date	24 Sep 2009



Ordering Information

LM	1	2	3	-	155.52M
Type: LVDS Clock Series 5x7mm	Temperature Range: 1 = 0 to 70° C 2 = -40 to 85° C 3 = 0 to 85° C 4 = -20 to 70° C	Frequency Stability: 4 = +/-20 ppm ^ 1 = +/-25 ppm ^ 2 = +/-50 ppm 3 = +/-100 ppm	Supply Voltage: 2 = 2.5Vdc. 3 = 3.3Vdc.		Output Frequency: Frequency Format -xxx.xM Min.* -xxx.xxxxxM Max.* *Amount of numbers after the decimal point. M = MHz

^ Models LM212, LM213, LM242 and LM243 are not currently available.
Example: LM123-155.52M = LVDS Clock, 0 to 70°C, +/-50ppm, 3.3Vdc @ 155.52 MHz

Package Characteristics

Package	Hermetically sealed ceramic package and metal cover.
Soldering Process	RoHS compliant, see solder profile on page 2.

Environmental Characteristics

Vibration:	Vibration per Mil Std 883E Method 2007.3 Test Condition A
Shock:	Mechanical Shock per Mil Std 883E Method 2002.4 Test Condition B.
Soldering:	SMD product suitable for Convection Reflow soldering. Peak temperature 260°C. Maximum time above 220°C, 60 seconds.
Solderability	Solderability per Mil Std 883E Method 2003

Pad Connections - Enable / Disable Function

Pad	Connection
1	Enable / Disable
2	N/C
3	Ground
4	Q Output
5	Q Output
6	Vcc

Enable / Disable Function (Pad 1)	Output
High or Open	Enable
Low	Disable (High Impedance)

Model Matrix

Frequency Tolerance ±20ppm	Frequency Tolerance ±25ppm	Frequency Tolerance ±50ppm	Frequency Tolerance ±100ppm	Supply Voltage	Temperature Range
LM142	LM112	LM122	LM132	2.5Vdc	0 to 70°C
LM442	LM412	LM422	LM432	2.5Vdc	-20 to 70°C
LM342	LM312	LM322	LM332	2.5Vdc	0 to 85°C
x	x	LM222	LM232	2.5Vdc	-40 to 85°C
LM143	LM113	LM123	LM133	3.3Vdc	0 to 70°C
LM443	LM413	LM423	LM433	3.3Vdc	-20 to 70°C
LM343	LM313	LM323	LM333	3.3Vdc	0 to 85°C
x	x	LM223	LM233	3.3Vdc	-40 to 85°C

X = Models LM212, LM213, LM242 and LM243 are not currently available.

Tape and Reel Specifications

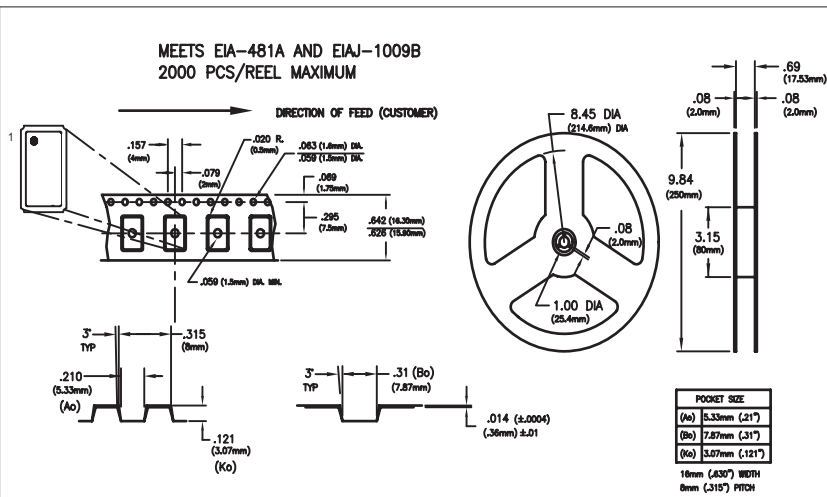

Package Outline

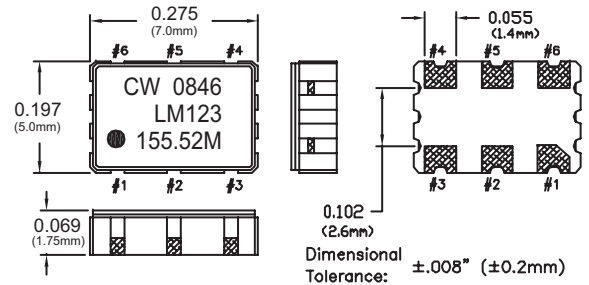

Suggested Pad Layout

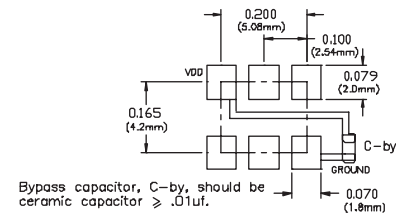

LVDS Output Waveform

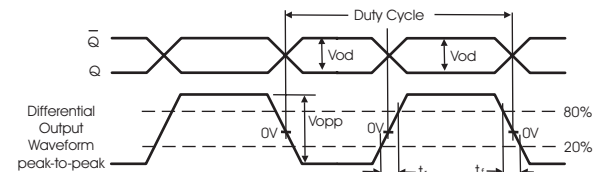

Test Circuit

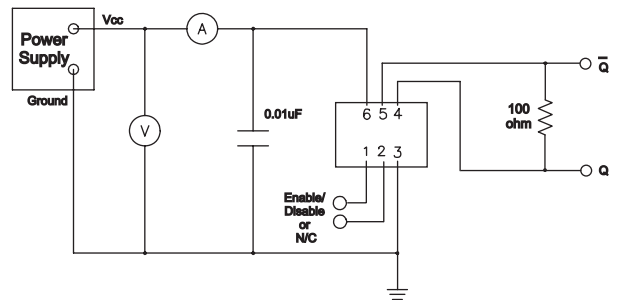

Solder Profile

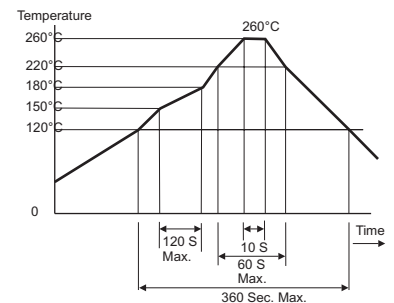

US Headquarters:
630-851-4722
European Headquarters:
+ 353-61-472221

Bulletin	Ds030
Page	2 of 2
Revision	P01
Date	24 Sep 2009