

Very Low Input /Very Low Dropout 3 Amp Regulator With Enable

POWER MANAGEMENT

Features

- Input voltage range from 1.8V to 5.5V
- Typical 300mV dropout @ 3A
- Adjustable output from 1.24V
- Over-current and over-temperature protection
- Enable pin
- 10 μ A shutdown current
- Full industrial temperature range
- TO263-5 package, fully WEEE and RoHS compliant

Applications

- Telecom/networking equipment
- Motherboards/peripheral cards
- Industrial equipment
- Wireless infrastructure
- Set-top boxes
- Medical equipment

Description

The SC4217 is a 3A, high performance LDO designed for use in applications requiring very low input voltage and very low dropout voltage. It operates with an input voltage as low as 1.8V and a programmable output voltage from 1.24V. The SC4217 features ultra- low dropout, ideal for applications where V_{OUT} is very close to V_{IN} . Additionally, the SC4217 has an enable pin to further reduce power dissipation while shut down. The SC4217 provides excellent regulation over line, load and temperature.

The SC4217 is available in a TO263-5 package and is fully WEEE and RoHS compliant.

Typical Application Circuit

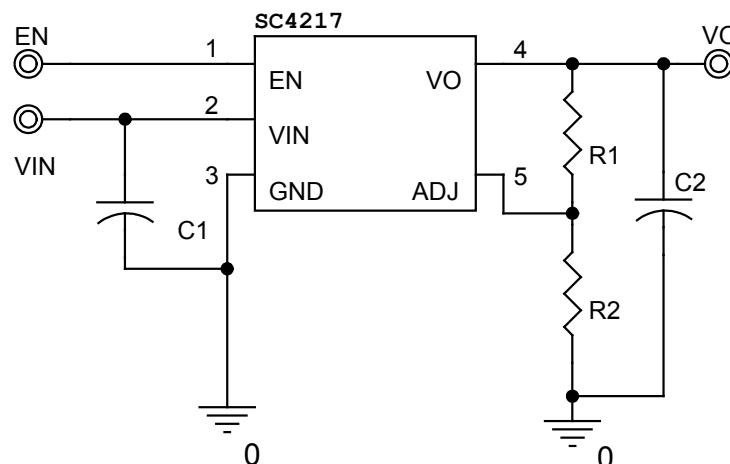

Pin Configuration

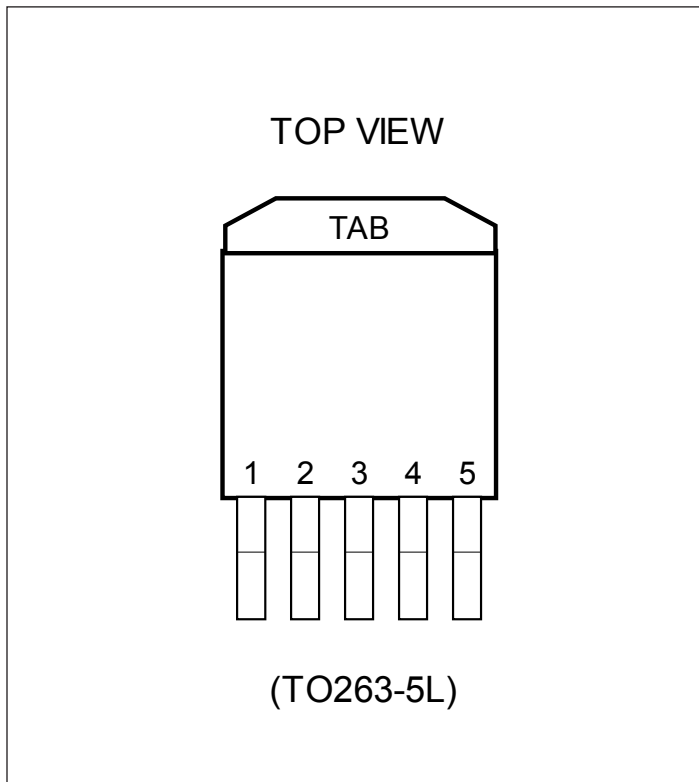

Ordering Information

Device	Package
SC4217MTRT ^{(1)/(2)}	TO263-5
SC4217EVB	Evaluation Board

Notes:

- 1) Available in tape and reel only. A reel contains 800 devices.
- 2) Device is WEEE and RoHS compliant.

Marking Information

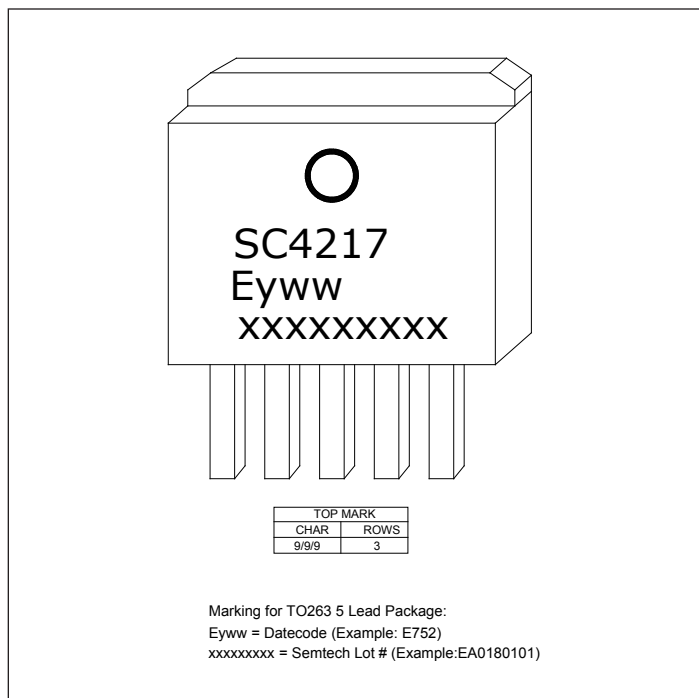

Absolute Maximum Ratings

V _{IN} , V _O , ADJ to GND	6V
EN	-0.3V to V _{IN} +0.3V
Lead Temperature (Soldering) 10s	300°C
ESD Protection Level	2kV

Recommended Operating Conditions

V _{IN} Range.....	1.8V to 5.5V
Maximum Output Current.....	3A
Operating Ambient Temperature Range	-40 to +85°C
Operating Junction Temperature Range.....	-40 to +125°C
Storage Temperature Range	-65 to +150°C

Thermal Information

Thermal Resistance, junction to case J $\theta_{JC}^{(1)}$	3°C/W
Thermal Resistance, junction to ambient J θ_{JA}	30°C/W

Other Notes:

Tested according to JEDEC standard JESD22-A114-B.

1) Calculated from package in still air, mounted to 3" x 4.5", 4 layer FR4 PCB with thermal vias under the exposed pad per JESD51 standards.

Exceeding the above specifications may result in permanent damage to the device or device malfunction.

Operation outside of the parameters specified in the Electrical Characteristics section is not recommended.

Electrical Characteristics

1) Unless otherwise noted, V_{EN} = V_{IN}. V_{IN} = 1.8V to 5.5V, V_{IN} = V_O+0.5V, and I_O = 10 μ A to 3A.

2) Values in bold apply over the full operating temperature range.

Parameter	Symbol	Conditions	Min	Typ	Max	Units
V_{IN}						
Quiescent Current	I _Q	V _{IN} = 3.3V		0.75	1.75	mA
		V _{IN} = 5.5V, V _{EN} = 0V		10	50	μ A
V_O						
Output Voltage ⁽¹⁾	V _O	V _{IN} = V _O + 0.5V	-2%		+2%	V
			-3%		+3%	
Line Regulation ⁽¹⁾	REG _(LINE)	I _O = 10mA		0.2	0.4	%/V
Load Regulation ⁽¹⁾	REG _(LOAD)	I _O = 10mA to 3A		0.5	1.0	%
Dropout Voltage ^(1, 2)	V _D	I _O = 1A		90	300	mV
					400	
		I _O = 1.5A		200	400	
Dropout Voltage ^(1, 2)	V _D	I _O = 3A, V _{IN} = V _O + 0.5V		300	500	mV
					600	
Minimum Load Current ⁽³⁾	I _O	V _{IN} = V _O + 0.5V		1	10	μ A
Current Limit	I _{CL}		3.3	4.5	6.75	A

Electrical Characteristics (continued)

Parameter	Symbol	Conditions	Min	Typ	Max	Units
ADJ						
Reference Voltage ⁽¹⁾	V_{REF}	$V_{IN} = 3.3V, V_{ADJ} = V_{OUT}, I_O = 10mA$	1.227	1.24	1.252	V
			1.215		1.265	
Adjust Pin Current ⁽⁴⁾	I_{ADJ}	$V_{ADJ} = V_{REF}$		80	200	nA
Adjust Pin Threshold ⁽⁵⁾	$V_{TH(ADJ)}$		0.05	0.16	0.40	V
EN						
Enable Pin Current	I_{EN}	$V_{EN} = 0V, V_{IN} = 3.3V$		1.5	10	μA
Enable Pin Theshold	V_{IH}	$V_{IN} = 3.3V$	1.6			V
	V_{IL}	$V_{IN} = 3.3V$			0.4	
Over Temperature Protection						
High Trip Level	T_{HI}			160		$^{\circ}C$
Hysteresis	T_{HYST}			10		

Notes:

- 1) Low duty cycle pulse testing with Kelvin connections required.
- 2) Defined as the input to output differential at which the output voltage drops to 1.5% below the value measured at a differential of 0.8V.
- 3) Required to maintain regulation. Voltage set resistors R1 and R2 are usually utilized to meet this requirement. Adjustable versions only.
- 4) Guaranteed by design.
- 5) When V_{ADJ} exceeds this threshold, the "Sense Select" switch disconnects the internal feedback chain from the error amplifier and connects V_{ADJ} instead.

Pin Descriptions

Pin #	Pin Name	Pin Function
1	EN	Enable input. Pulling this pin below 0.4V turns off the regulator reducing the quiescent current to a fraction of its operating value. The device will be enabled if this pin is left open. Connect to V_{IN} if not being used.
2	VIN	Input voltage. For regulation at full load, the input to this pin must be between $(V_O+0.5V)$ and 5.5V. Minimum $V_{IN} = 1.8V$. A large bulk capacitance should be placed closey to this pin to ensure that the input supply does not sag below 1.8V. A minimum of 4.7 μ F ceramic capacitors should be placed directly at this pin.
3	GND	Reference ground. The GND pin and the exposed die pad must be connected together at the IC pin.
4	VO	The pin is the power output of the device. A minimum of 10 μ F capacitor should be placed directly at this pin.
5	ADJ	Use external feedback resistors to program the output voltage. See application circuit on page 1. $V_O = [(R_2+R_1)*1.24V]/R_2$. The ADJ pin cannot be tied directly either to VO pin or to GND pin.
T	THERMAL PAD	Thermal pad should be connected to PCB ground plane for thermal and electrical purposes.

Block Diagram

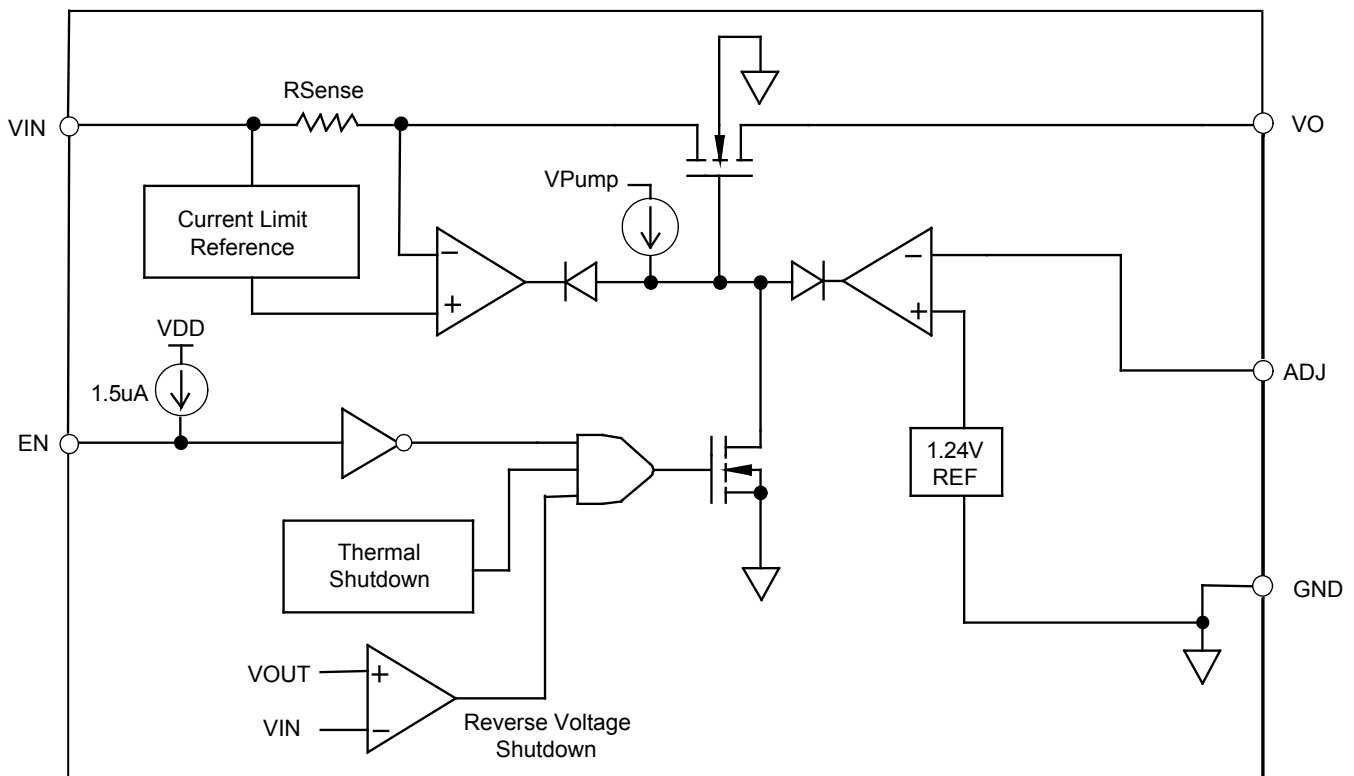

Typical Characteristics

1) Unless otherwise noted, typical values are taken under the conditions: $T_{AMBIENT}=25^{\circ}C$, $V_{IN}=3.3V$, $V_O=2.5V$, $I_O=2A$, $C_{IN}=C_{OUT}=0.1\mu F$ (Ceramic)+ $10\mu F$ (Tantalum)

Dropout Voltage vs Output Current

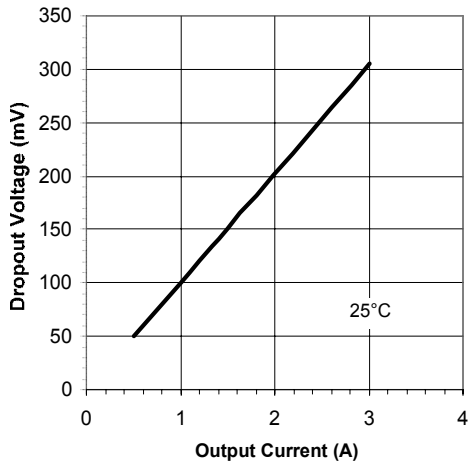

Dropout Voltage vs Temperature

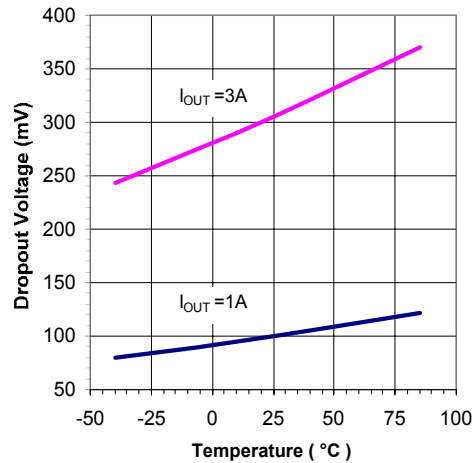

ADJ Pin Leakage Current vs Temperature

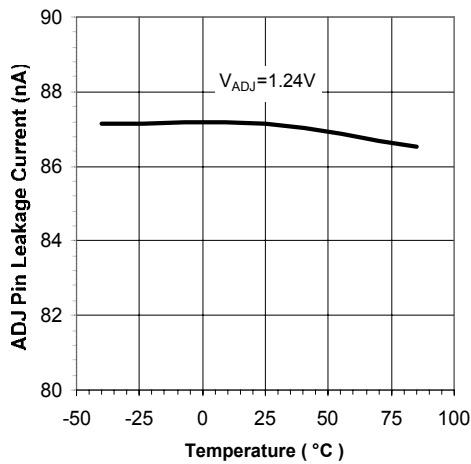

Quiescent Current vs Input Voltage

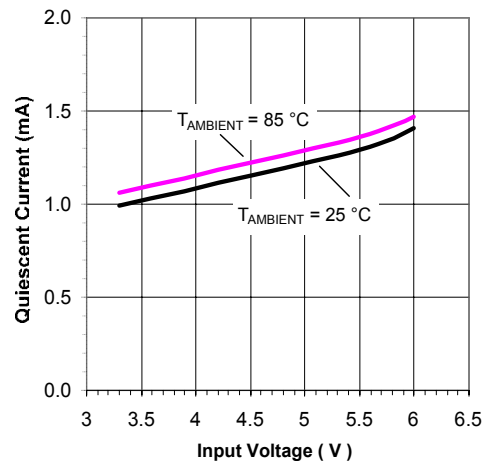

Enable Voltage High vs Temperature

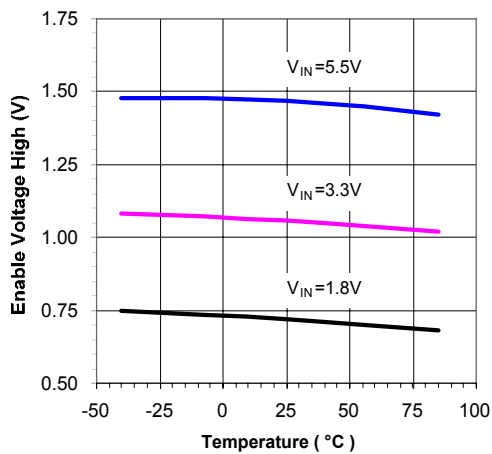

Enable Voltage Low vs Temperature

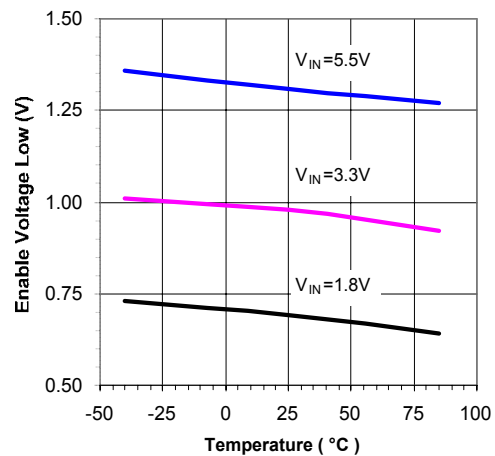

Typical Characteristics

1) Unless otherwise noted, typical values are taken under the conditions: $T_{\text{AMBIENT}}=25^{\circ}\text{C}$, $V_{\text{IN}}=3.3\text{V}$, $V_{\text{O}}=2.5\text{V}$, $I_{\text{O}}=2\text{A}$, $C_{\text{IN}}=C_{\text{OUT}}=0.1\mu\text{F}(\text{Ceramic})+10\mu\text{F}(\text{Tantalum})$

Soft start performance

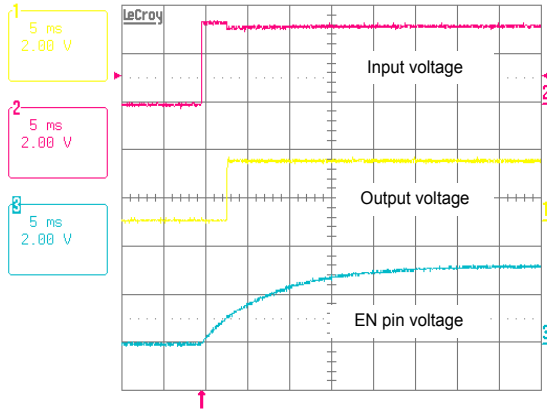

Load transient test

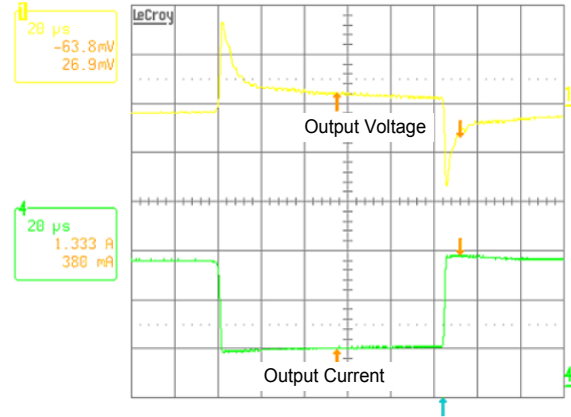

Applications Information

Introduction

The SC4217 is intended for applications where high current capability and very low dropout voltage are required. It provides a very simple, low cost solution that uses very little PCB real estate. Additional features include an enable pin to allow for a very low power consumption standby mode, and a fully adjustable output.

Component Selection

Input Capacitor

A minimum of 4.7µF ceramic or tantalum capacitor is recommended to be placed directly next to the Vin pin. This allows for the device being some distance from any bulk capacitance on the rail. Additionally, bulk capacitance of about $\geq 10\mu\text{F}$ may be added closely to the input supply pin of the SC4217 to ensure that Vin does not sag, improving load transient response.

Output Capacitor

A minimum bulk capacitance of $\geq 10\mu\text{F}$, along with a 0.1µF ceramic decoupling capacitor is recommended. Increasing the bulk capacitance will improve the overall transient response. The use of multiple lower value ceramic capacitors in parallel to achieve the desired bulk capacitance will not cause stability issues. Although designed for use with ceramic output capacitors, the SC4217 is extremely tolerant of output capacitor ESR values and thus will also work comfortably with tantalum output capacitors.

Noise immunity

In very electrically noisy environments, it is recommended that 0.1µF ceramic capacitors be placed from IN to GND and OUT to GND as close to the device pins as possible.

External Voltage Selection Resistors

The use of 1% resistors, and designing for a current flow $\geq 10\mu\text{A}$ is recommended to ensure a well regulated output (thus $R2 \leq 50\text{k}\Omega$).

Enable

Pulling this pin below 0.4V turns the regulator off, reducing the quiescent current to a fraction of its operating value.

Thermal Considerations

The power dissipation in the SC4217 is approximately equal to the product of the output current and the input to output voltage differential:

$$P_D \approx (V_{IN} - V_{OUT}) \times I_O$$

The absolute worst-case dissipation is given by:

$$P_D \approx (V_{IN(\text{MAX})} - V_{OUT(\text{MIN})}) \times I_{O(\text{MAX})} + V_{IN(\text{MAX})} \times I_{Q(\text{MAX})}$$

For a typical scenario, $V_{IN} = 3.3\text{V} \pm 5\%$, $V_{OUT} = 2.8\text{V}$ and $I_O = 1.5\text{A}$, therefore:

$$V_{IN(\text{MAX})} = 3.465\text{V}, V_{OUT(\text{MIN})} = 2.744\text{V} \text{ and } I_{Q(\text{MAX})} = 1.75\text{mA},$$

$$\text{Thus } P_{D(\text{MAX})} = 1.09\text{W}.$$

Using this figure, and assuming $T_{A(\text{MAX})} = 70^\circ\text{C}$, we can calculate the maximum thermal impedance allowable to maintain $T_J \leq 150^\circ\text{C}$:

$$R_{TH(J-A)(\text{MAX})} = \frac{(T_{J(\text{MAX})} - T_{A(\text{MAX})})}{P_{D(\text{MAX})}} = \frac{(150 - 70)}{1.09} = 73.4^\circ\text{C/W}$$

This should be achievable for the TO263-5 package using pcb copper area to aid in conducting the heat away, such as one square inch of copper connected to the exposed die pad of the device. Internal ground/power planes and air flow will also assist in removing heat. For higher ambient temperatures it may be necessary to use additional copper area.

Typical Application Circuits

Figure 1: Application circuit with 3.3V input and 2.5V output

Outline Drawing — TO263-5



DIM	INCHES			MILLIMETERS		
	MIN	NOM	MAX	MIN	NOM	MAX
A	.160	-	.190	4.06	-	4.83
A1	.000	-	.010	0.00	-	0.25
b	.020	-	.039	0.51	-	0.99
c	.015	-	.029	0.38	-	0.74
c1	.045	-	.065	1.14	-	1.65
D	.326	-	.380	8.28	-	9.65
D1	.270	-	-	6.86	-	-
E	.380	-	.420	9.65	-	10.67
E1	.245	-	-	6.22	-	-
H	.575	-	.625	14.61	-	15.88
e	.067 BSC			1.70 BSC		
L	.070	-	.110	1.78	-	2.79
L1	-	-	.066	-	-	1.68
N	5			5		
θ	-	15°	-	-	15°	-
θ1	0°	-	8°	0°	-	8°
aaa	.010			0.25		

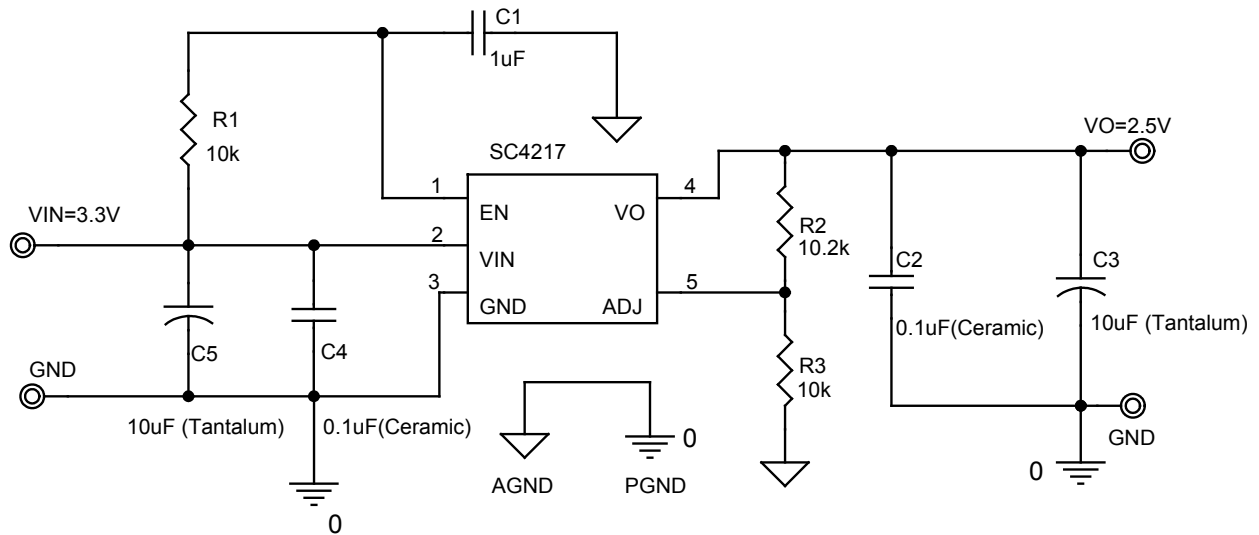
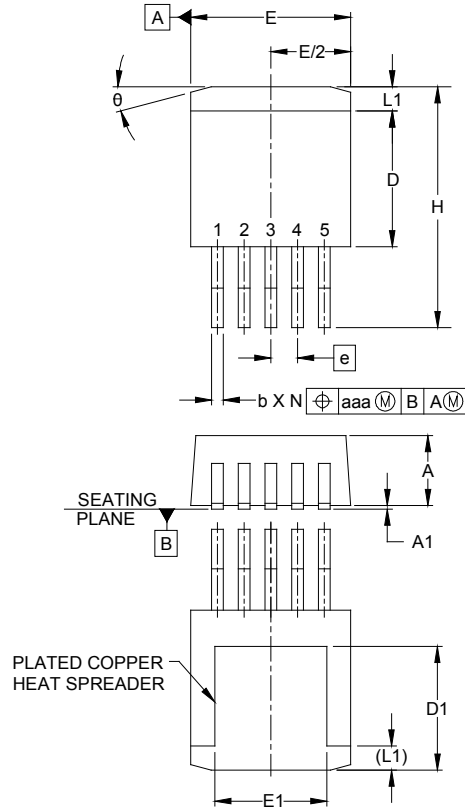
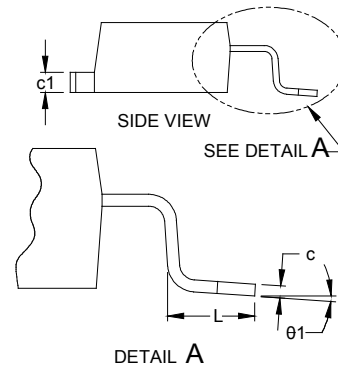

NOTES:

1. CONTROLLING DIMENSIONS ARE IN INCHES (ANGLES IN DEGREES).
2. DIMENSIONS "D" AND "E" DO NOT INCLUDE MOLD FLASH, PROTRUSIONS OR GATE BURRS.

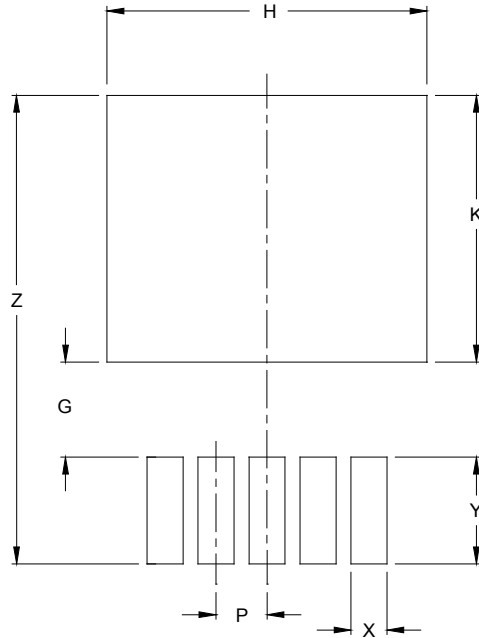
Land Pattern — T0263-5

DIMENSIONS		
DIM	INCHES	MILLIMETERS
G	.125	3.17
H	.420	10.67
K	.350	8.89
P	.067	1.70
X	.042	1.07
Y	.140	3.56
Z	.615	15.62

NOTES:

1. THIS LAND PATTERN IS FOR REFERENCE PURPOSES ONLY
CONSULT YOUR MANUFACTURING GROUP TO ENSURE YOUR
COMPANY'S MANUFACTURING GUIDELINES ARE MET.

Contact Information

Semtech Corporation
 Power Management Products Division
 200 Flynn Road, Camarillo, CA 93012
 Phone: (805) 498-2111 Fax: (805) 498-3804

www.semtech.com