



## PA7493

CMOS IC

### 2W X 2 CLASS AB AUDIO POWER AMPLIFIER (WITH DC\_VOLUME CONTROL)

#### DESCRIPTION

UTC **PA7493** provides precise DC volume control, and a stereo bridged audio power amplifiers capable of producing 2W into 4Ω as a monolithic integrated circuit. In stand-by the power consumption is very low. UTC **PA7493** combines a stereo single-end (SE) mode for headphone drive into a single chip and a stereo bridge-tied loads ( $\overline{\text{BTL}}$ ) mode for speaker drive(both modes are easily switched by the SE/ $\overline{\text{BTL}}$  input control signal) to simplify the audio system design. Package size is not occupies PCB space cause the built-in over-temperature protection. It is suitable for small or portable products.

#### FEATURES

- \* Stereo switch able bridged/single-ended power amplifiers
- \* Output power 2W × 2 ( $V_{CC}=6V$ , THD=1%,  $R_L=4\Omega$ )
- \* Low harmonics distortion
- \* Include 32 steps volume controller by DC voltage with hysteresis
- \* "Click and pop" suppression circuitry
- \* Low current consumption in SHUTDOWN Mode(0.7μA)
- \* Thermal shutdown

#### ORDERING INFORMATION

Ordering Number		Package	Packing
Normal	Lead Free Plating		
PA7493-D16-T	PA7493L-D16-T	DIP-16	Tube

<p>PA7493L-D16-T</p> <p>(1)Packing Type (2)Package Type (3)Lead Plating</p>	<p>(1) T: Tube (2) D16: DIP-16 (3) L: Lead Free Plating, Blank: Pb/Sn</p>
-------------------------------------------------------------------------------------	-----------------------------------------------------------------------------------

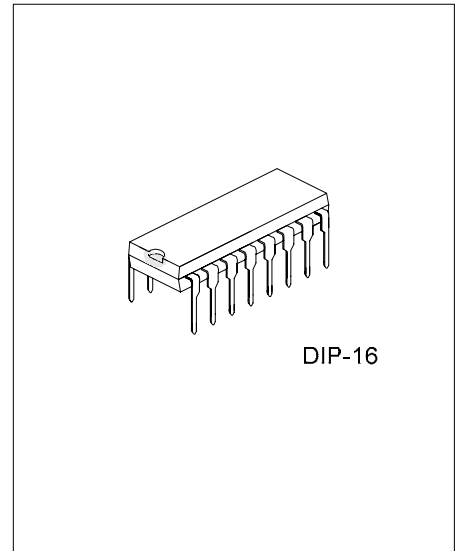

\*Pb-free plating product number: PA7493L

■ PIN CONFIGURATION

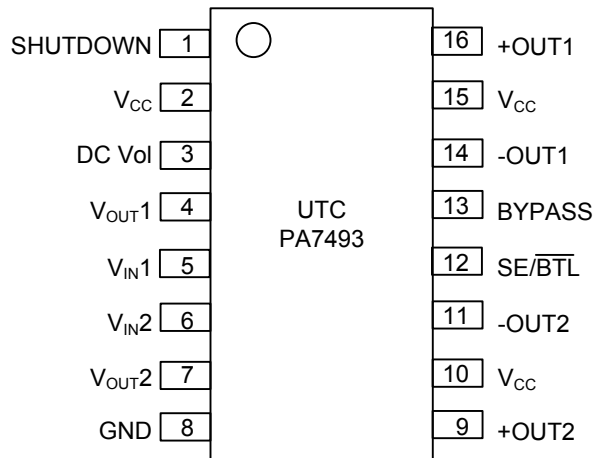

■ PIN DESCRIPTION

PIN NO	PIN NAME	I/O	DESCRIPTION
1	SHUTDOWN	I	When this pin connected to the $V_{CC}$ entire IC into the shutdown mode
2	$V_{CC}$		Supply voltage input pin
3	DC Vol	I	DC Volume control input
4	$V_{OUT1}$	I	Output of Channel 1 for external feedback circuit
5	$V_{IN1}$	I	Input of Channel 1 audio
6	$V_{IN2}$	I	Input of Channel 2 audio
7	$V_{OUT2}$	I	Output of Channel 2 for external feedback circuit
8	GND		Ground
9	+OUT2	O	Output (+) of Channel 2
10	$V_{CC}$		Supply voltage input
11	-OUT2	O	Output (-) of Channel 2
12	SE/BTL	I	Output mode select, which is connected to the $V_{CC}$ for SE mode or GND for BTL mode
13	BYPASS	O	Internal bias reference bypassing
14	-OUT1	O	Output (-) of Channel 1
15	$V_{CC}$		Supply voltage input
16	+OUT1	O	Output (+) of Channel 1

■ BLOCK DIAGRAM

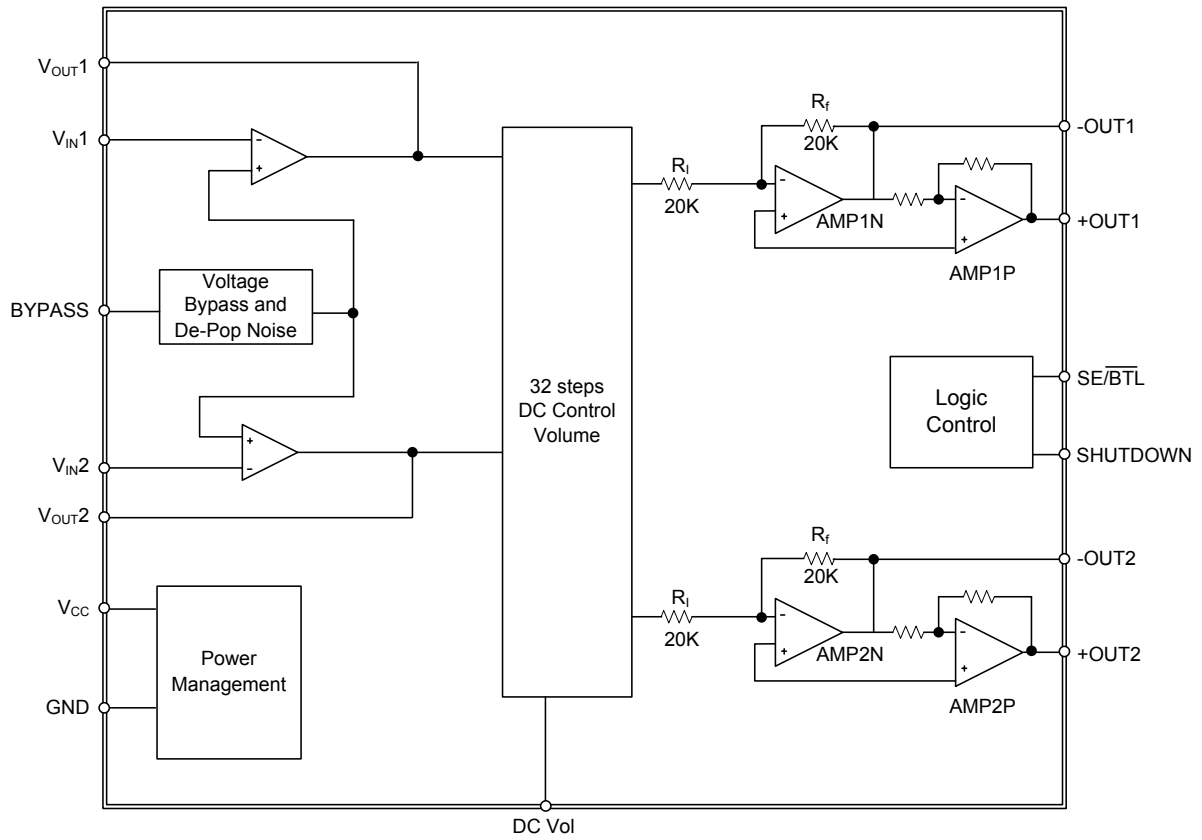

### ■ ABSOLUTE MAXIMUM RATINGS

PARAMETER	SYMBOL	RATINGS	UNIT
Supply Voltage	$V_{CC}$	0~7	V
Input Voltage	$V_{IN}$	-0.3~ $V_{CC}+0.3$	V
Input Current	$I_{IN}$	-10~+10	mA
Operating Temperature	$T_{OPR}$	-40~+85	
Storage Temperature	$T_{STG}$	-65~+150	

Note: 1. Absolute maximum ratings are those values beyond which the device could be permanently damaged. Absolute maximum ratings are stress ratings only and functional device operation is not implied.  
2. Input pins surge current can be reached 100mA will not induce the CMOS latched up.

### ■ ELECTRICAL CHARACTERISTICS

PARAMETER	SYMBOL	TEST CONDITIONS	MIN	TYP	MAX	UNIT	
<b>FOR ENTIRE IC</b> ( $V_{CC}=5V$ , $T_A=25$ , unless otherwise specified.)							
Supply Voltage	$V_{CC}$		3	5	6	V	
Quiescent Power Supply Current	$I_{CC}$	SE MODE	6	8	12	mA	
		BTL MODE	8	10	14		
Shutdown Current	$I_{SD}$	SHUTDOWN=ON	0.2	0.7	1	$\mu A$	
Threshold Voltage	High Level	$V_{IH}$	SHUTDOWN	0.5	0.6	$V_{CC}$	
		SE/BTL	0.8	0.9	$V_{CC}$		
	Low Level	$V_{IL}$	SHUTDOWN		0.2	0.3	$V_{CC}$
		SE/BTL			0.1	0.2	$V_{CC}$
<b>FOR VOLUME ATTENUATORS</b> ( $V_{CC}=5V$ , $T_A=25$ , unless otherwise specified.)							
Two Channels Gain Error	Gerr	$R_{IN}=R_F=20K\Omega$	-1	0	+1	dB	
Volume Control Range	$V_{CTRL}$	DC Vol=5V, F=1KHz	-1	0	+1	dB	
		DC Vol =16.875% $V_{CC}$	-46	-47	-48		
Mute Attenuation	AM	$V_{MUTE}=5V$	BTL	-78		dB	
			SE	-78		dB	
<b>FOR SINGLE-ENDED MODE OPERATION</b> ( $V_{CC}=5V$ , bandwidth = 22~22 KHz, Unless otherwise specified.)							
Maximum Output Power	$P_{OUT}$	$R_L=32\Omega$	THD=1.0%	80	85	90	mW
			THD=10%	100	110	120	
Total Harmonic Distortion Plus Noise	THD+N	$P_{OUT}=50mW$ , $R_L=32\Omega$	0.03	0.05	0.07	%	
Power Ripple Rejection Ratio	PSRR	$V_{RIPPLE}=200mV_{rms}$ , $C_B=1\mu F$ , $F_{in}=120Hz$		58		dB	
Signal to Noise Ratio	SNR	$P_{OUT}=75mW$ , $R_L=32\Omega$ , A-weight		102		dB	
Channel Separation	Xtalk	$C_B=1\mu F$ , $F_{in}=1kHz$	77	80	83	dB	
<b>FOR BRIDGED MODE OPERATION</b> ( $V_{CC}=5V$ , bandwidth = 22~22 KHz, Unless otherwise specified.)							
Output Offset Voltage	$V_{O(OFF)}$	$V_{IN}=0V$ , No Load	-50	5	50	mV	
Maximum Output Power	$P_{OUT}$	THD+N=1%, $R_L=4\Omega$	1.4	1.6	1.8	W	
		THD+N=10%, $R_L=4\Omega$	1.8	2.0	2.1		
		THD+N=1%, $R_L=4\Omega$ , $V_{CC}=6V$	1.9	2.0	2.2		
		THD=1%, $R_L=8\Omega$	1.0	1.1	1.2		
		THD+N=10%, $R_L=8\Omega$	1.2	1.4	1.6		
Total Harmonic Distortion Plus Noise	THD+N	$P_{OUT}=0.2W$ , $R_L=4\Omega$	0.03	0.05	0.07	%	
		$P_{OUT}=1W$ , $R_L=4\Omega$	0.06	0.08	0.15		
Power Ripple Rejection Ratio	PSRR	$V_{RIPPLE}=200mV_{rms}$ , $R_L=8\Omega$ , $C_B=1\mu F$ , $F_{in}=120Hz$		74		dB	
Signal to Noise Ratio	SNR	$P_{OUT}=1.1W$ , $R_L=8\Omega$ , A-weight		93		dB	
Channel Separation	Xtalk	$C_B=1\mu F$ , $F_{in}=1kHz$	85	88	91	dB	

## ■ FUNCTION DESCRIPTION

### POWER SUPPLY

The UTC **PA7493** operating voltage range is from 3V to 6V. In general, the 5V operating voltage is recommended. When the supply voltage less than 3V, the IC can work properly but the distortion will rise. The higher stand-by current consumption will rise the chip surface temperature after the operating voltage over 6.5V.

### SHUTDOWN

After powering on the UTC **PA7493**, connects the SHUTDOWN pin to  $V_{CC}$  will force the chip into shutdown mode. At the shutdown mode, the total current consumption is less than 0.7 $\mu$ A, and all of the input/output pins no voltage output. The chip is back to the normal operation when the SHUTDOWN pin sets to GND.

SHUTDOWN PIN	OUTPUT STATE
$V_{CC}$	SHUTDOWN ON
GND	Normal

### INPUT GAIN ADJUST

The output gain of the UTC **PA7493** can be adjusted by the external resistor. 0dB gain setting is recommended in normal operation, please refer the application circuit. If the source output level is not so high (ex :< 2V<sub>PP</sub>), input gain can be increased to get the proper volume. The minimum value of the input series resistance is 10K $\Omega$  for the modest input impedance.

To make sure the input stage not distorted by overload, please confirm the input signal level. For the gain set please refer the following table:

Operating Voltage	Input Gani=-6db	Input Gain=0db	Input Gani=+6db
$V_{CC}=3V$	$V_{IN}<5V_{PP}$	$V_{IN}<2.5V_{PP}$	$V_{IN}<1.25V_{PP}$
$V_{CC}=5V$	$V_{IN}<8V_{PP}$	$V_{IN}<4V_{PP}$	$V_{IN}<2V_{PP}$

### SE/BTL MODE SWITCHING

The UTC **PA7493** has two output modes, SE(Single-Ended) or BTL(Bridge-Tied Load). To drive a speaker load, set to the BTL mode is recommended for getting the more power output. Driving a headphone load, we suggest setting to SE mode and turn-off the un-work amplifier to decrease the stand-by power consumption. Switching between the SE and BTL modes is controlled by the SE/BTL pin, please refer the following table:

SE/BTL	MODE
$V_{CC}$	SE
GND	BTL

### CLICK AND POP SURPPRESS

A power amplifier uses single supply voltage may cause noises on the output port during the power-on period. It is because of the output DC potential level needs time to stable on 1/2V<sub>CC</sub>, the period is relative with the capacitor on the BYPASS pin. The higher capacitor value will extend the stable time and also suppress the noise during the power-on period. At the supply voltage is 5V and the capacitor is 2.2 $\mu$ F, the stable time is around 300ms. The value of the BYPASS capacitor also relatives with the DC blocking capacitor connected at the input terminal. In general condition the time constant of DC blocking capacitor should be less than the CB stable time. Recommend parts values please refer the application circuit.

■ VOLUME CONTROL TABLE

Gain (dB)	Voltage Range (% of V <sub>CC</sub> )			Voltage Range (V <sub>CC</sub> = 5)			Voltage Range (V <sub>CC</sub> = 3)		
	Low	High	Recommended	Low	High	Recommended	Low	High	Recommended
0	77.5%	100.00%	100.000%	3.875	5.000	5.000	2.325	3.000	3.000
-1	75.0%	78.5%	76.875%	3.750	3.938	3.844	2.250	2.363	2.306
-2	72.5%	76.25%	74.375%	3.625	3.813	3.719	2.175	2.288	2.231
-3	70.0%	73.75%	71.875%	3.500	3.688	3.594	2.100	2.213	2.156
-4	67.5%	71.25%	69.375%	3.375	3.563	3.469	2.025	2.138	2.081
-5	65.0%	68.75%	66.875%	3.250	3.438	3.344	1.950	2.063	2.006
-6	62.5%	66.25%	64.375%	3.125	3.313	3.219	1.875	1.988	1.931
-8	60.0%	63.75%	61.875%	3.000	3.188	3.094	1.800	1.913	1.856
-10	57.5%	61.25%	59.375%	2.875	3.063	2.969	1.725	1.838	1.781
-12	55.0%	58.75%	56.875%	2.750	2.938	2.844	1.650	1.763	1.706
-14	52.5%	56.25%	54.375%	2.625	2.813	2.719	1.575	1.688	1.631
-16	50.0%	53.75%	51.875%	2.500	2.688	2.594	1.500	1.613	1.556
-18	47.5%	51.25%	49.375%	2.375	2.563	2.469	1.425	1.538	1.481
-20	45.0%	48.75%	46.875%	2.250	2.438	2.344	1.350	1.463	1.406
-22	42.5%	46.25%	44.375%	2.125	2.313	2.219	1.275	1.388	1.331
-24	40.0%	43.75%	41.875%	2.000	2.188	2.094	1.200	1.313	1.256
-26	37.5%	41.25%	39.375%	1.875	2.063	1.969	1.125	1.238	1.181
-28	35.0%	38.75%	36.875%	1.750	1.938	1.844	1.050	1.163	1.106
-30	32.5%	36.25%	34.375%	1.625	1.813	1.719	0.975	1.088	1.031
-32	30.0%	33.75%	31.875%	1.500	1.688	1.594	0.900	1.013	0.956
-34	27.5%	31.25%	29.375%	1.375	1.563	1.469	0.825	0.937	0.881
-36	25.0%	28.75%	26.875%	1.250	1.438	1.344	0.750	0.862	0.806
-39	22.5%	26.25%	24.375%	1.125	1.313	1.219	0.675	0.787	0.731
-42	20.0%	23.75%	21.875%	1.000	1.188	1.094	0.600	0.712	0.656
-45	17.5%	21.25%	19.375%	0.875	1.063	0.969	0.525	0.637	0.581
-47	15.0%	18.75%	16.875%	0.750	0.937	0.844	0.450	0.562	0.506
-51	12.5%	16.25%	14.375%	0.625	0.812	0.719	0.375	0.487	0.431
-56	10.0%	13.75%	11.875%	0.500	0.687	0.594	0.300	0.412	0.356
-61	7.5%	11.25%	9.375%	0.375	0.562	0.469	0.225	0.337	0.281
-66	5.0%	8.75%	6.875%	0.250	0.437	0.344	0.150	0.262	0.206
-78	0.0%	6.25%	0.000%	0.000	0.312	0.000	0.000	0.187	0.000

