

Structure	Silicon Monolithic Integrated Circuit
Product Name	Step-up DC/DC converter for medium size LCD panel
Type	BD6150MUV
Features	High efficiency PWM step-up DC/DC converter (fsw=1.25MHz) High accuracy and good matching current driver 6ch (MAX 30mA/ch) Drive up to 10 in series x 6 strings in parallel =60 white LEDs

●Absolute Maximum Ratings (Ta=25°C)

Parameter	Symbol	Rating	Unit	Condition
Maximum applied voltage 1	VMAX1	7	V	VREG, ISET, PWMDRV, FSEL, OCPSET, VDET, TEST
Maximum applied voltage 2	VMAX2	25	V	LED1, LED2, LED3 LED4, LED5, LED6
Maximum applied voltage 3	VMAX3	30.5	V	VBAT, FAILFLAG, PWMPOW
Maximum applied voltage 4	VMAX4	41	V	SW
Power dissipation 1	Pd1	500	mW	*1
Power dissipation 2	Pd2	780	mW	*2
Power dissipation 3	Pd3	1510	mW	*3
Operating temperature range	Topr	-40 ~ +85	°C	-
Storage temperature range	Tstg	-55 ~ +150	°C	-

*1 Reduced 4.0mW/°C With Ta>25°C when not mounted on a heat radiation Board.

*2 1 layer (ROHM Standard board) has been mounted. Copper foil area 0mm², When it's used by more than Ta=25°C, it's reduced by 6.2mW/°C.

*3 4 layer (JEDEC Compliant board) has been mounted. Copper foil area 1layer 6.28mm², Copper foil area 2~4layers 5655.04mm²,
When it's used by more than Ta=25°C, it's reduced by 12.1mW/°C.

●Operating conditions (Ta=-40 to +85°C)

Parameter	Symbol	Rating			Unit	Condition
		Min.	Typ	Max		
Supply voltage	VBAT	4.2	12.0	26.0	V	

This product isn't designed to protect itself against radioactive rays.

●Electrical Characteristics

(Unless otherwise noted, VBAT=12V, Ta = +25°C)

Parameter	Symbol	Limits			Unit	Condition
		Min.	Typ.	Max.		
Quiescent current	Iq	-	1.6	4.4	μA	PWMPOW=PWMDRV=0V
Current consumption	Idd	-	3.6	5.4	mA	VDET=0V,ISET=22kΩ
[PWMPOW Terminal]						
Low input voltage range1	POWL	0	-	0.9	V	
High input voltage range1	POWH	2.1	-	VBAT	V	
Pull down resistor1	POWR	100	300	500	kΩ	PWMPOW=2.5V
[PWMDRV Terminal]						
Low input voltage range2	PDRV1	0	-	0.9	V	
High input voltage range2	PDRVH	2.1	-	6.0	V	
Pull down resistor2	DRVR	100	300	500	kΩ	PWMDRV=2.5V
[FSEL Terminal]						
Low input voltage range3	FSL	0	-	0.9	V	
High input voltage range3	FSH	2.1	-	6.0	V	
Pull down resistor3	FSR	100	300	500	kΩ	FSEL=2.5V
[FAILFLAG]						
Input resistor	FFIR	1.0	2.0	3.0	kΩ	FAILFLAG=2.5V
Off current	FFIST	-	0.1	2.0	μA	PWMPOW=0V
[Regulator]						
VREG voltage	VREG	4.2	5.0	6.0	V	No load
Under voltage lock out	UVLO	3.3	3.7	4.1	V	VBAT falling edge
[Switching Regulator]						
LED control voltage	VLED	0.56	0.70	0.84	V	
Switching frequency	fsw	1.00	1.25	1.50	MHz	FSEL=L (GND short)
Duty cycle limit	Duty	91.0	95.0	99.0	%	LED1-6=0.3V
SW Nch FET RON	RON	-	0.48	0.58	Ω	ISW=80mA
[Protection]						
Over current limit	Ocp	1.4	2.0	2.6	A	*1 OCPSET=68kΩ
OCPSET open protect	OOP	-	0.0	0.1	A	OCPSET=2MΩ
Over voltage limit Input	Ovi	0.96	1.00	1.04	V	Detect voltage of VDET pin
SBD open protect	Sop	0.02	0.05	0.08	V	Detect voltage of VDET pin
VDET leak current	OVIL	-	0.1	1.0	μA	
[Current driver]						
LED maximum current	ILMAX	-	-	30	mA	
LED current accuracy	ILACCU	-	-	±3.0	%	ILED=16~20mA
LED current matching	ILMAT	-	-	±1.5	%	Each LED current/Average (LED1-6) ILED=16~20mA
LED current limiter	ILOCP	-	0	0.1	mA	Current limit value at ISET resistor 1kΩ setting
LED terminal Over voltage protect	LEDOVP	10.0	11.5	13.0	V	PWMDRV=2.5V
ISET voltage	Iset	0.5	0.6	0.7	V	

*1 This parameter is tested with dc measurement.

●Package outline drawing

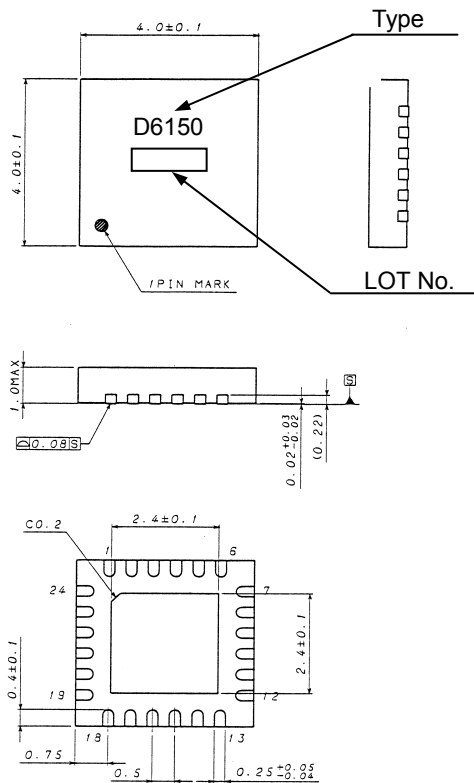

VQFN024V4040 (Unit : mm)

●Terminals

PIN	PIN Name
1	SW
2	SW
3	N.C.
4	PGND
5	FAILFLAG
6	OCPSET
7	VDET
8	TEST
9	FSEL
10	ISET
11	GND
12	N.C.
13	LED1
14	LED2
15	LED3
16	LED4
17	LED5
18	LED6
19	N.C.
20	GND
21	PWMDRV
22	VREG
23	PWMPW
24	VBAT

●Block diagram

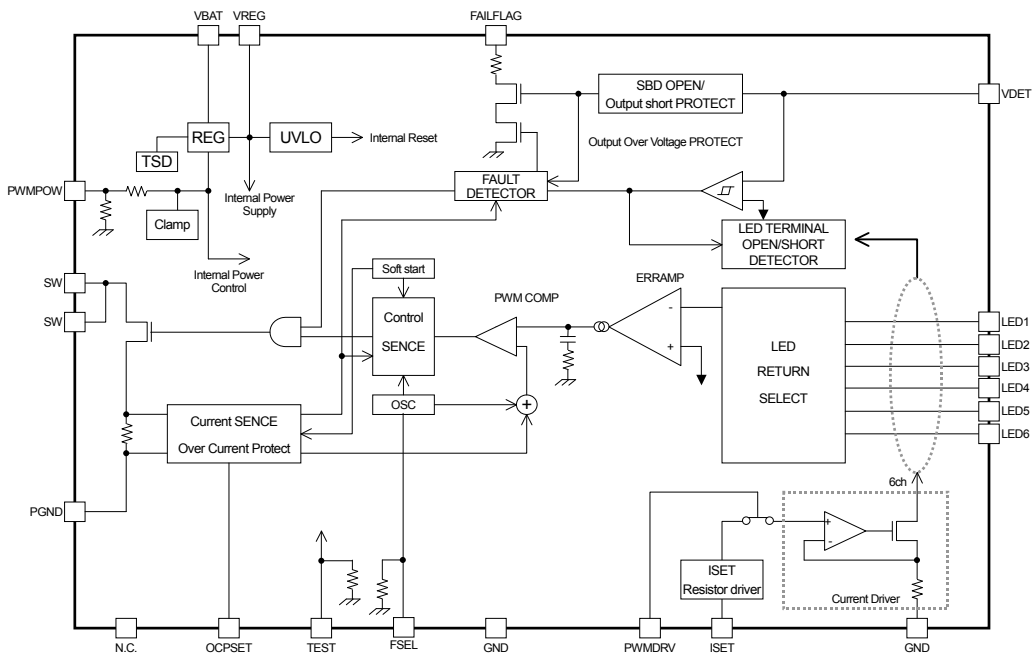

●Cautions on use**(1) Absolute Maximum Ratings**

An excess in the absolute maximum ratings, such as supply voltage, temperature range of operating conditions, etc., can break down devices, thus making impossible to identify breaking mode such as a short circuit or an open circuit. If any special mode exceeding the absolute maximum ratings is assumed, consideration should be given to take physical safety measures including the use of fuses, etc.

(2) Operating conditions

These conditions represent a range within which characteristics can be provided approximately as expected. The electrical characteristics are guaranteed under the conditions of each parameter.

(3) Reverse connection of power supply connector

The reverse connection of power supply connector can break down ICs. Take protective measures against the breakdown due to the reverse connection, such as mounting an external diode between the power supply and the IC's power supply terminal.

(4) Power supply line

Design PCB pattern to provide low impedance for the wiring between the power supply and the GND lines. In this regard, for the digital block power supply and the analog block power supply, even though these power supplies has the same level of potential, separate the power supply pattern for the digital block from that for the analog block, thus suppressing the diffraction of digital noises to the analog block power supply resulting from impedance common to the wiring patterns. For the GND line, give consideration to design the patterns in a similar manner.

Furthermore, for all power supply terminals to ICs, mount a capacitor between the power supply and the GND terminal. At the same time, in order to use an electrolytic capacitor, thoroughly check to be sure the characteristics of the capacitor to be used present no problem including the occurrence of capacity dropout at a low temperature, thus determining the constant.

(5) GND voltage

Make setting of the potential of the GND terminal so that it will be maintained at the minimum in any operating state. Furthermore, check to be sure no terminals are at a potential lower than the GND voltage including an actual electric transient.

(6) Short circuit between terminals and erroneous mounting

In order to mount ICs on a set PCB, pay thorough attention to the direction and offset of the ICs. Erroneous mounting can break down the ICs. Furthermore, if a short circuit occurs due to foreign matters entering between terminals or between the terminal and the power supply or the GND terminal, the ICs can break down.

(7) Operation in strong electromagnetic field

Be noted that using ICs in the strong electromagnetic field can malfunction them.

(8) Inspection with set PCB

On the inspection with the set PCB, if a capacitor is connected to a low-impedance IC terminal, the IC can suffer stress. Therefore, be sure to discharge from the set PCB by each process. Furthermore, in order to mount or dismount the set PCB to/from the jig for the inspection process, be sure to turn OFF the power supply and then mount the set PCB to the jig. After the completion of the inspection, be sure to turn OFF the power supply and then dismount it from the jig. In addition, for protection against static electricity, establish a ground for the assembly process and pay thorough attention to the transportation and the storage of the set PCB.

(9) Input terminals

In terms of the construction of IC, parasitic elements are inevitably formed in relation to potential. The operation of the parasitic element can cause interference with circuit operation, thus resulting in a malfunction and then breakdown of the input terminal. Therefore, pay thorough attention not to handle the input terminals, such as to apply to the input terminals a voltage lower than the GND respectively, so that any parasitic element will operate. Furthermore, do not apply a voltage to the input terminals when no power supply voltage is applied to the IC. In addition, even if the power supply voltage is applied, apply to the input terminals a voltage lower than the power supply voltage or within the guaranteed value of electrical characteristics.

(10) Ground wiring pattern

If small-signal GND and large-current GND are provided, It will be recommended to separate the large-current GND pattern from the small-signal GND pattern and establish a single ground at the reference point of the set PCB so that resistance to the wiring pattern and voltage fluctuations due to a large current will cause no fluctuations in voltages of the small-signal GND. Pay attention not to cause fluctuations in the GND wiring pattern of external parts as well.

(11) External capacitor

In order to use a ceramic capacitor as the external capacitor, determine the constant with consideration given to a degradation in the nominal capacitance due to DC bias and changes in the capacitance due to temperature, etc.

(12) Thermal shutdown circuit (TSD)

When junction temperatures become 175°C (typ) or higher, the thermal shutdown circuit operates and turns a switch OFF. The thermal shutdown circuit, which is aimed at isolating the LSI from thermal runaway as much as possible, is not aimed at the protection or guarantee of the LSI. Therefore, do not continuously use the LSI with this circuit operating or use the LSI assuming its operation.

(13) Thermal design

Perform thermal design in which there are adequate margins by taking into account the permissible dissipation (Pd) in actual states of use.

(14) Selection of coil

Select the low DCR inductors to decrease power loss for DC/DC converter.

Notes

No copying or reproduction of this document, in part or in whole, is permitted without the consent of ROHM Co.,Ltd.

The content specified herein is subject to change for improvement without notice.

The content specified herein is for the purpose of introducing ROHM's products (hereinafter "Products"). If you wish to use any such Product, please be sure to refer to the specifications, which can be obtained from ROHM upon request.

Examples of application circuits, circuit constants and any other information contained herein illustrate the standard usage and operations of the Products. The peripheral conditions must be taken into account when designing circuits for mass production.

Great care was taken in ensuring the accuracy of the information specified in this document. However, should you incur any damage arising from any inaccuracy or misprint of such information, ROHM shall bear no responsibility for such damage.

The technical information specified herein is intended only to show the typical functions of and examples of application circuits for the Products. ROHM does not grant you, explicitly or implicitly, any license to use or exercise intellectual property or other rights held by ROHM and other parties. ROHM shall bear no responsibility whatsoever for any dispute arising from the use of such technical information.

The Products specified in this document are intended to be used with general-use electronic equipment or devices (such as audio visual equipment, office-automation equipment, communication devices, electronic appliances and amusement devices).

The Products specified in this document are not designed to be radiation tolerant.

While ROHM always makes efforts to enhance the quality and reliability of its Products, a Product may fail or malfunction for a variety of reasons.

Please be sure to implement in your equipment using the Products safety measures to guard against the possibility of physical injury, fire or any other damage caused in the event of the failure of any Product, such as derating, redundancy, fire control and fail-safe designs. ROHM shall bear no responsibility whatsoever for your use of any Product outside of the prescribed scope or not in accordance with the instruction manual.

The Products are not designed or manufactured to be used with any equipment, device or system which requires an extremely high level of reliability the failure or malfunction of which may result in a direct threat to human life or create a risk of human injury (such as a medical instrument, transportation equipment, aerospace machinery, nuclear-reactor controller, fuel-controller or other safety device). ROHM shall bear no responsibility in any way for use of any of the Products for the above special purposes. If a Product is intended to be used for any such special purpose, please contact a ROHM sales representative before purchasing.

If you intend to export or ship overseas any Product or technology specified herein that may be controlled under the Foreign Exchange and the Foreign Trade Law, you will be required to obtain a license or permit under the Law.



Thank you for your accessing to ROHM product informations.
More detail product informations and catalogs are available, please contact us.

ROHM Customer Support System

<http://www.rohm.com/contact/>