

PLEASE CHECK WWW.MOLEX.COM FOR LATEST PART INFORMATION

Part Number: [0194200002](#)
Status: **Active**
Overview: [mx150l sealed connector system](#)
Description: MX150L™ Female Terminal for 18-22 AWG Wire, Tin Plated, Metal Strip Carrier

Documents:

[Drawing \(PDF\)](#) [RoHS Certificate of Compliance \(PDF\)](#)
[Product Specification PS-19417-001 \(PDF\)](#)

Agency Certification

CSA LR18689
 UL E152602

General

Product Family Crimp Terminals
 Series [19420](#)
 Comments UL E152602
 Crimp Quality Equipment Yes
 Overview [mx150l sealed connector system](#)
 Product Literature Order No 987650-2181
 Product Name MX150L™

Physical

Flammability 94V-0
 Gender Female
 Material - Metal High Performance Alloy (HPA)
 Material - Plating Mating Tin
 Material - Plating Termination Tin
 Packaging Type Reel
 Plating min: Mating (µin) 75.2
 Plating min: Mating (µm) 1.88
 Plating min: Termination (µin) 75.2
 Plating min: Termination (µm) 1.88
 Termination Interface: Style Crimp or Compression
 Wire Insulation Diameter 2.36-2.74mm (.093-.108")
 Wire Size AWG 18, 19, 20, 22
 Wire Size mm² N/A

Material Info

Reference - Drawing Numbers

Product Specification PS-19417-001
 Sales Drawing SD-19420-001

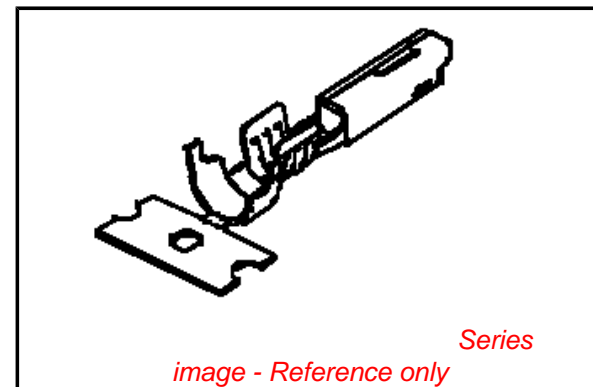

EU RoHS

ELV and RoHS Compliant
REACH SVHC Contains SVHC: No
Halogen-Free Status

China RoHS



Halogen-Free

Need more information on product environmental compliance?

Email productcompliance@molex.com
 For a multiple part number RoHS Certificate of Compliance, [click here](#)

Please visit the [Contact Us](#) section for any non-product compliance questions.

Search Parts in this Series

[19420Series](#)

Mates With

[19417](#)

Use With

[19418](#)

Application Tooling | FAQ

Tooling specifications and manuals are found by selecting the products below. Crimp Height Specifications are then contained in the Application Tooling Specification document.

Global

Description	Product #
Hand Crimp Tool	0638114400
Hand Crimp Tool	0638117600
Fine Adjust for MX150L™ for Female Terminal 18-24 AWG	0639008400

T2 Terminator for MX150L™ Crimp Terminal, Female 18-24 AWG	<u>0639108400</u>
Manual Extraction Tool	<u>0638131500</u>

This document was generated on 06/01/2010

PLEASE CHECK WWW.MOLEX.COM FOR LATEST PART INFORMATION

STRIP MATERIAL NUMBER	LOOSE PIECE MATERIAL NUMBER	AWG SIZE	FINISH	DIM. "A"	DIM. "B"	DIM. "C"	DIM. "D"
194200001	194200009	16-14	PREPLATED TIN 75µ MIN THICK OVER NICKEL FLASH	.235/5.97	.182/4.62	.141/3.58	.155/3.94
194200002	194200010	22-18		.179/4.55	.143/3.63	.098/2.50	.106/2.70
194200003	194200011	16-14	SELECT HARD GOLD 30µ MIN. THICK WITH SELECT TIN 100µ MIN. OVER NICKEL 50µ MIN. OVERALL	.235/5.97	.182/4.62	.141/3.58	.155/3.94
194200004	194200012	22-18		.179/4.55	.143/3.63	.098/2.50	.106/2.70

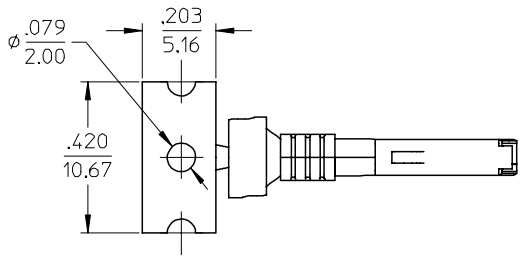
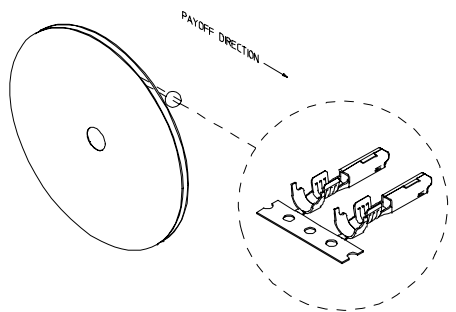
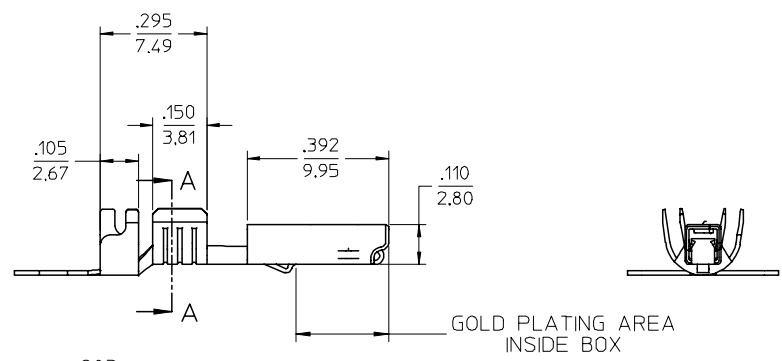
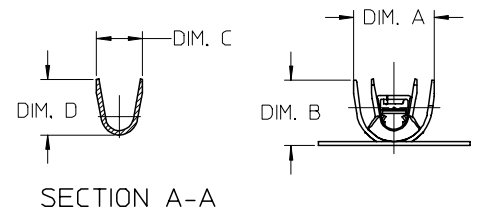
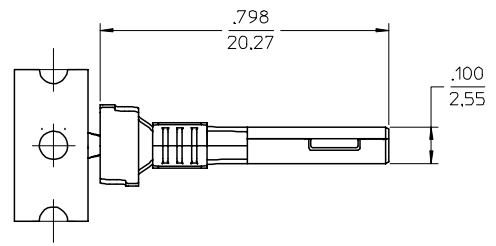

- NOTES:
1. MATERIAL: COPPER ALLOY .0098/0.249 THK.
 2. FINISH: SEE CHART.
 3. TERMINALS FOR USE WITH 19418-**** RECEPTACLE HOUSING ASSEMBLY.
 4. STRIP TERMINALS ARE REELED AS SHOWN ABOVE ON 24" REELS, 4000 PARTS PER REEL.
 5. LOOSE TERMINALS ARE BULK PACKAGED IN QUANTITIES OF 400.
 6. APPLICATION TOOLING AND CRIMP SPECIFICATIONS: 63865-6200 (14-16 AWG), 63865-6300 (14-16 AWG), 63811-4000 (HAND TOOL).

EC NO: ETC2004-0249 DRWN: JPAWLICK 2004/06/25 CHKD: JPAWLICK 2004/06/25 APPR: RDEROSS 2004/06/25	QUALITY SYMBOLS ▽ - 0 ◻ - 0	GENERAL TOLERANCES (UNLESS SPECIFIED)		SCALE 4:1	DESIGN UNITS INCH	THIRD ANGLE PROJECTION	REVISE ON CAD ONLY		
		4 PLACES ± --- ± ---	3 PLACES ± --- ± .010	DIMENSION STYLE IN/MM		TITLE FEMALE RECEPTACLE TERMINAL, 22-18 & 16-14 AWG, .059/1.50X.031/0.79			
		2 PLACES ± 0.25 ± .02	1 PLACE ± 0.5 ± ---	ANGULAR ± 3 °		DRAWN BY JPAWLICK DATE 05/05/03	MOLEX INCORPORATED		
		DRAFT WHERE APPLICABLE MUST REMAIN WITHIN DIMENSIONS		CHECKED BY RDEROSS DATE 05/05/03	APPROVED BY RDEROSS DATE 05/05/03	MATERIAL NO. SEE CHART	DOCUMENT NO. SD-19420-001	SHEET NO. 1 OF 1	