

Negative Voltage Regulator

FEATURES

- Low power consumption.
- Low temperature coefficient.
- Output short-circuit protection.
- Wide operating voltage range.
- Good input stability.
- Space-saving packages - TO-92 or SOT-89

APPLICATIONS

- LCD for Printing Calculators
- Cameras
- Voltage References for Instrumentation

DESCRIPTION

The SS6714 is a series of 3-terminal negative voltage regulators with output voltages internally set below the positive supply voltage. Since the SS6714 consumes less current and requires a smaller input/output voltage difference than existing industry-standard 3-terminal voltage regulators, higher capacity and longer service life can be provide in battery-powered portable equipment. The SS6714 is ideal as a power source for liquid crystal displays.

TYPICAL APPLICATION CIRCUIT

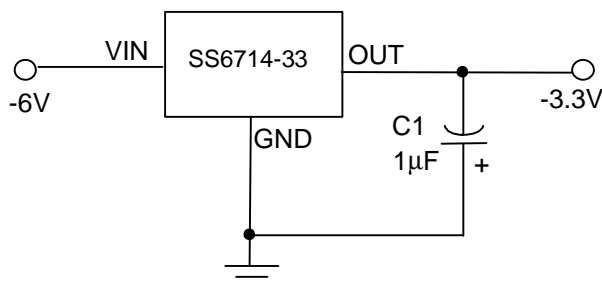

Negative Voltage Regulator

ORDERING INFORMATION

SS6714-XXCXXX

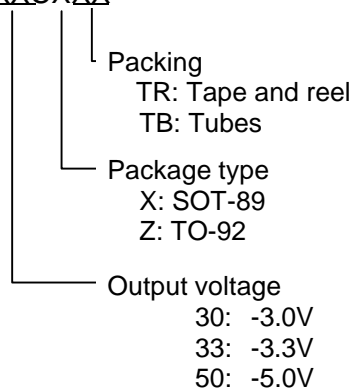

Example: SS6714-30CXTR
 → -3.0V output, in SOT-89 package
 shipped in tape and reel

PIN CONFIGURATION

SOT-89
 TOP VIEW
 1. VIN
 2. GND
 3. VOUT

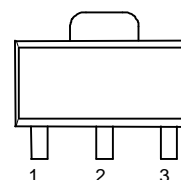

TO-92
 TOP VIEW
 1. GND
 2. VIN
 3. VOUT

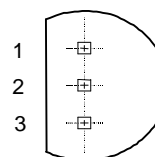

ABSOLUTE MAXIMUM RATINGS

Supply Voltage	-13V
Operating Temperature Range	- 20°C~80°C
Storage Temperature Range	- 65°C~150°C
Power Dissipation	SOT-89 Package 0. 80W
	TO-92 Package 0.78W

TEST CIRCUIT

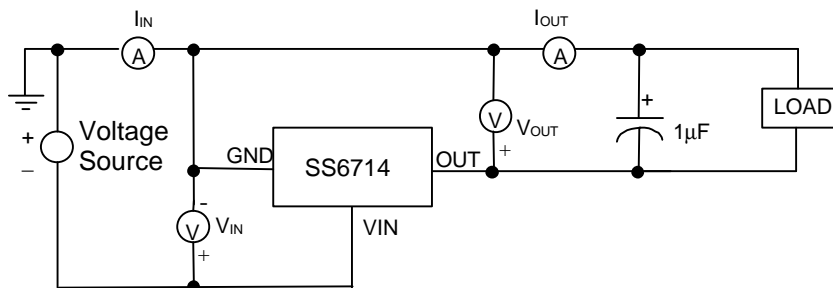

ELECTRICAL CHARACTERISTICS (VIN= -6.0V, TJ=25°C, unless otherwise specified.)

PARAMETER	TEST CONDITIONS	SYMBOL	MIN.	TYP.	MAX.	UNIT
Output Voltage	I _{OUT} =300µA	SS6714-30	-2.95	-3.0	-3.05	V
		SS6714-33	-3.25	-3.3	-3.35	V
		SS6714-50	-4.93	-5.0	-5.07	V
Load Regulation	I _{OUT} =0~5mA	ΔV _{OUT}		20	100	mV
I/O Voltage Difference	I _{OUT} =300µA	V _{DIFF}		50	200	mV
Supply Current	I _{OUT} =0	I _{IN}		6	12	µA
Input Stability		$\frac{\Delta V_{OUT}}{\Delta V_{IN} \cdot V_{OUT}}$		0.05		%/ V
Temperature Coefficient	-25°C~85°C	T _C		50		ppm
Output Short Circuit Current	R _{LOAD} =0		15	24		mA

TYPICAL PERFORMANCE CHARACTERISTICS

Fig. 1 Output Voltage vs. Supply Voltage
(Load Current=300 μA)



Supply Current vs. Supply Voltage
(No Load)

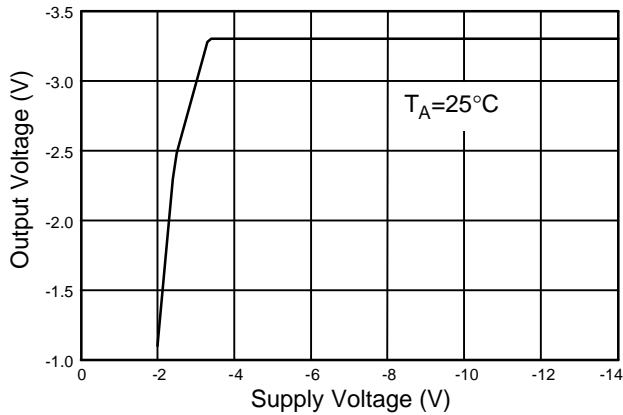
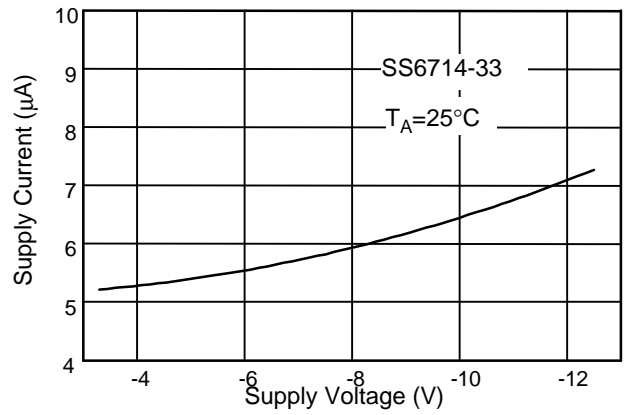
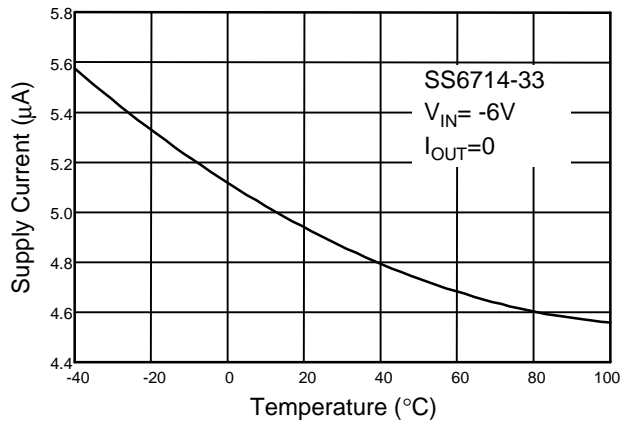

Fig. 3 Supply Current vs Temperature

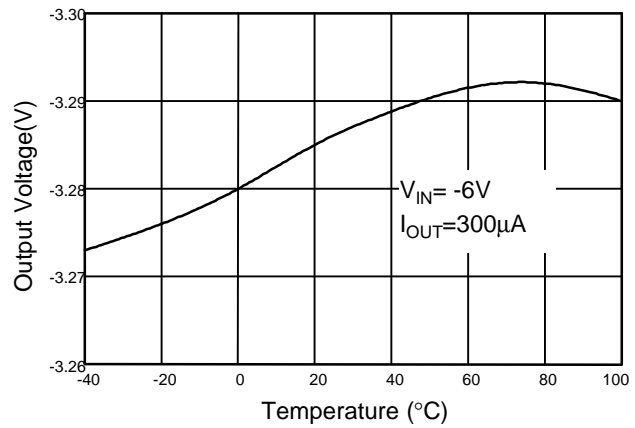

Fig. 4 Output Voltage vs Temperature

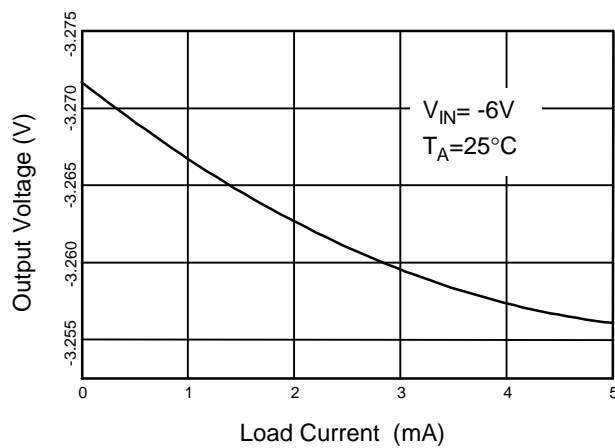
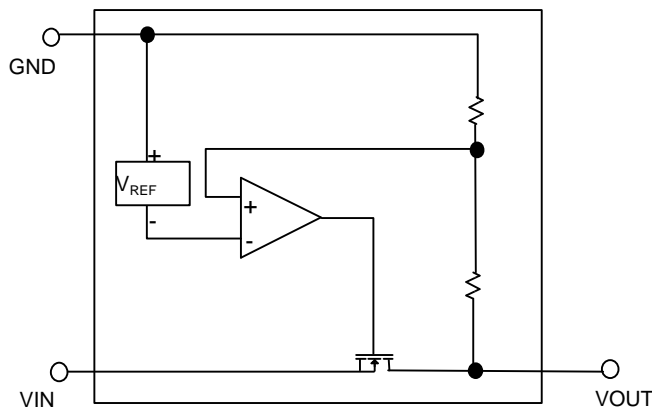

Fig. 5 Output Voltage vs Load Current

BLOCK DIAGRAM



PIN DESCRIPTIONS

VOUT PIN - Output pin.

GND PIN - Power GND.

VIN PIN - Power Supply Input.

APPLICATION INFORMATION

A capacitor of at least 1 μ F is required between the output of the SS6714 and ground for stability. Without this capacitor the part will oscillate. Even though most types of capacitor may work, the equivalent series resistance (ESR) should be held to 5 Ω or less if an aluminum electrolytic type is used. Many aluminum electrolytic capacitors have electrolytes that freeze at about -30°C, so solid

tantalum capacitors are recommended for operation below -25°C. The value of this capacitor may be increased without limit.

A capacitor of at least 0.1 μ F should be placed from the input of the SS6714 to ground if the lead inductance between the input and power source exceeds 500nH (approximately 10 inches of trace).

PHYSICAL DIMENSIONS

SOT-89 (unit: mm)

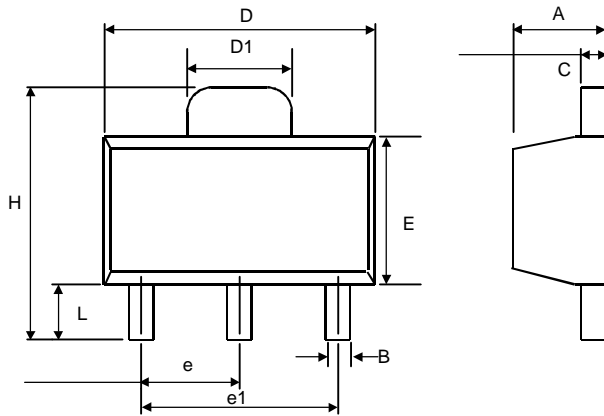

SYMBOL	MIN	MAX
A	1.40	1.60
B	0.36	0.48
C	0.35	0.44
D	4.40	4.60
D1	1.62	1.83
E	2.29	2.60
e	1.50 (TYP.)	
e1	3.00 (TYP.)	
H	3.94	4.25
L	0.89	1.20

SOT89 Marking

Part No.	Marking
SS6714-30	AP30
SS6714-33	AP33
SS6714-50	AP50

TO-92 (unit: mm)

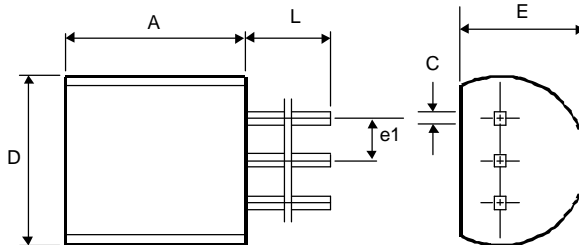

SYMBOL	MIN	MAX
A	4.32	5.33
C	0.38 (TYP.)	
D	4.40	5.20
E	3.17	4.20
e1	1.27 (TYP.)	
L	12.7	-

Information furnished by Silicon Standard Corporation is believed to be accurate and reliable. However, Silicon Standard Corporation makes no guarantee or warranty, express or implied, as to the reliability, accuracy, timeliness or completeness of such information and assumes no responsibility for its use, or for infringement of any patent or other intellectual property rights of third parties that may result from its use. Silicon Standard reserves the right to make changes as it deems necessary to any products described herein for any reason, including without limitation enhancement in reliability, functionality or design. No license is granted, whether expressly or by implication, in relation to the use of any products described herein or to the use of any information provided herein, under any patent or other intellectual property rights of Silicon Standard Corporation or any third parties.