

PLEASE CHECK WWW.MOLEX.COM FOR LATEST PART INFORMATION

Part Number: **0873401213**
Status: **Active**
Description: 2.00mm (.079") Pitch Milli-Grid™ Receptacle, Surface Mount (Very Low Profile), Top Entry, without Locating Peg, 0.76µm (30µ") Gold (Au) Plating, 12 Circuits, Lead-free, Tube

Documents:

[3D Model](#) [Product Specification PS-87340 \(PDF\)](#)
[Drawing \(PDF\)](#) [RoHS Certificate of Compliance \(PDF\)](#)

Agency Certification

CSA LR19980
 UL E29179

General

Product Family PCB Receptacles
 Series [87340](#)
 Application Board-to-Board
 Product Literature Order No 987650-1991
 Product Name Milli-Grid™

Physical

Circuits (Loaded) 12
 Color - Resin Black
 Durability (mating cycles max) 25
 Flammability 94V-0
 Glow-Wire Compliant No
 Lock to Mating Part Yes
 Material - Metal Phosphor Bronze
 Material - Plating Mating Gold
 Material - Plating Termination Tin
 Material - Resin High Temperature Thermoplastic
 Number of Rows 2
 Orientation Vertical
 PCB Locator No
 PCB Retention None
 PCB Thickness Recommended (mm) 0.80 mm
 Packaging Type Tube
 Pitch - Mating Interface (in) 0.079 In
 Pitch - Mating Interface (mm) 2.00 mm
 Plating min: Mating (µin) 30
 Plating min: Mating (µm) 0.76
 Plating min: Termination (µin) 76
 Plating min: Termination (µm) 1.9
 Polarized to Mating Part No
 Polarized to PCB No
 Surface Mount Compatible (SMC) N/A
 Temperature Range - Operating -55°C to +105°C
 Termination Interface: Style Surface Mount

Electrical

Current - Maximum per Contact 1A
 Voltage - Maximum 125V

Material Info

Reference - Drawing Numbers

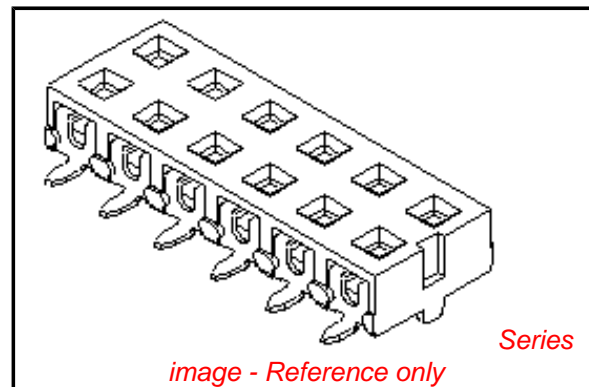

image - Reference only

EU RoHS

ELV and RoHS Compliant
REACH SVHC Contains SVHC: No
Halogen-Free Status
Not Reviewed

China RoHS



Need more information on product environmental compliance?

Email productcompliance@molex.com
 For a multiple part number RoHS Certificate of Compliance, [click here](#)

Please visit the [Contact Us](#) section for any non-product compliance questions.

Search Parts in this Series

[87340Series](#)

Mates With

[87759](#) Vertical, Surface Mount, Stackable PCB Headers, [87760](#) Right Angle, Through Hole, Stackable PCB Headers, [87758](#) Vertical, Through Hole, Stackable PCB Headers

This document was generated on 05/03/2010

PLEASE CHECK WWW.MOLEX.COM FOR LATEST PART INFORMATION

10 9 8 7 6 5 4 3 2 1

PART NO. IN TUBE	CKT. SIZE	DIM. B	DIM. A
87340-04**	4	2.00	4.00
87340-06**	6	4.00	6.00
87340-08**	8	6.00	8.00
87340-10**	10	8.00	10.00
87340-12**	12	10.00	12.00
87340-14**	14	12.00	14.00
87340-16**	16	14.00	16.00
87340-18**	18	16.00	18.00
87340-20**	20	18.00	20.00

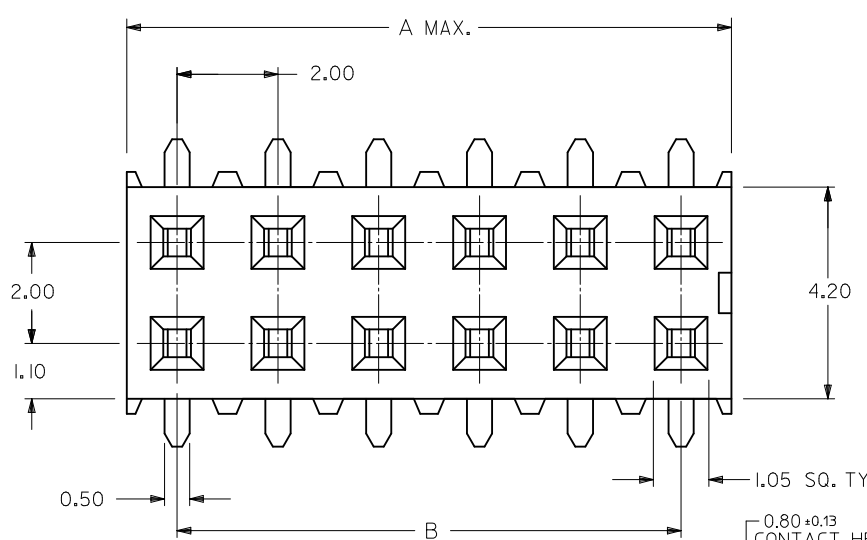

- NOTES:
- 12 CIRCUIT SIZE SHOWN FOR ILLUSTRATION ONLY. SEE CHART FOR AVAILABLE PART SIZES.
 - PLATING FINISH:
 - 3 & 8 - 0.76um/30uin MIN. GOLD IN CONTACT AREA
1.90um/75uin MIN. TIN IN SOLDER TAIL AREA
BOTH OVER 1.30um/50uin MIN. NICKEL OVERALL
 - 4 & 9 - 0.38um/15uin MIN. GOLD IN CONTACT AREA
1.90um/75uin MIN. TIN IN SOLDER TAIL AREA
BOTH OVER 1.30um/50uin MIN. NICKEL OVERALL
 - COPLANARITY OF SOLDER TAIL IS TO BE MEASURED BY RESTING THE PART ON A FLAT GAUGE SURFACE.
 - PRODUCT SPECIFICATION PS-87340 APPLIES.
 - THIS AREA OF PART TO BE HEAT STAKED TO RETAIN CONTACTS.
 - PART IS MATEABLE TO ALL MILLI-GRID HEADERS WITH MINIMUM PIN LENGTHS OF 1.90mm FOR TOP ENTRY.

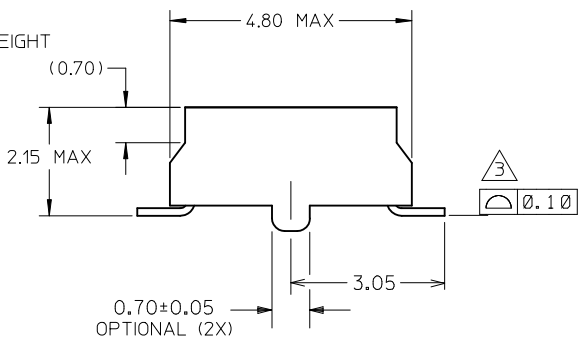
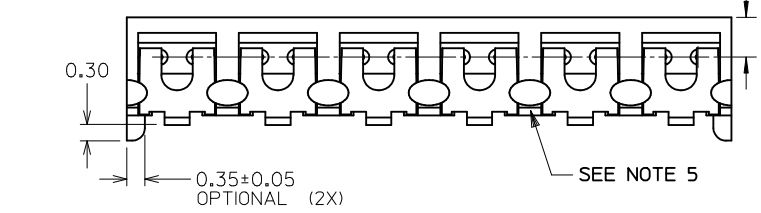

PART NO. LEGEND

- 87340 - * * * * *
- CIRCUIT SIZE
- PACKAGING & PLATING
- 3 - (TUBE WITH 0.76um MIN GOLD)
 - 4 - (TUBE WITH 0.38um MIN GOLD)
 - 8 - (T&R WITH 0.76um MIN GOLD)
 - 9 - (T&R WITH 0.38um MIN GOLD)

- 1 - WITHOUT LOCATING PEGS (HOUSING - BLACK)
- 2 - WITH LOCATING PEGS (HOUSING - BLACK)
- 5 - WITHOUT LOCATING PEGS (HOUSING - NATURAL)
- 6 - WITH LOCATING PEGS (HOUSING - NATURAL)

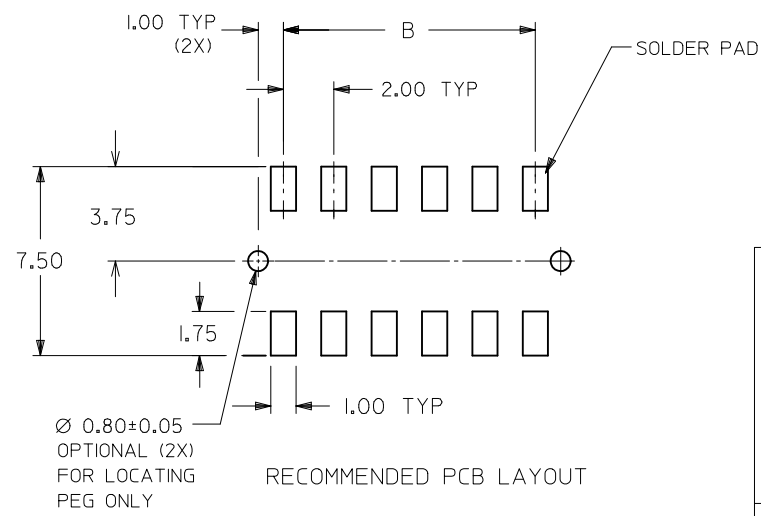

ADD T&R OPTION EC NO: S2010-0879 DRWN:SKANG CHKD:ATSEE APPR:MLONG	REV L4	DESCRIPTION 2010/04/22 2010/04/26 2010/04/27	QUALITY SYMBOLS F _A =0 F _G =0 F _P =0	GENERAL TOLERANCES (UNLESS SPECIFIED)		DIMENSION STYLE MM ONLY		SCALE NTS	DESIGN UNITS METRIC	THIRD ANGLE PROJECTION	
				mm	INCH	DRAWN BY JKACHL I	DATE 1991/07/02	TITLE MGRID VLPR II, 2MM DUAL ROW TOP ENTRY RECEPT., SMT			
				4 PLACES	± ---	± ---	CHECKED BY JNG	DATE 1991/07/09	MOLEX INCORPORATED DOCUMENT NO. SD-87340-**-01 SHEET NO. 1 OF 3		
				3 PLACES	± ---	± ---	APPROVED BY MLONG	DATE 2009/11/24			
				2 PLACES	± 0.20	± ---	MATERIAL NO. SEE TABLE				
				1 PLACE	± ---	± ---	SIZE A3		THIS DRAWING CONTAINS INFORMATION THAT IS PROPRIETARY TO MOLEX INCORPORATED AND SHOULD NOT BE USED WITHOUT WRITTEN PERMISSION		
				ANGULAR ± 3 °							
				DRAFT WHERE APPLICABLE MUST REMAIN WITHIN DIMENSIONS							

9 8 7 6 5 4 3 2 1

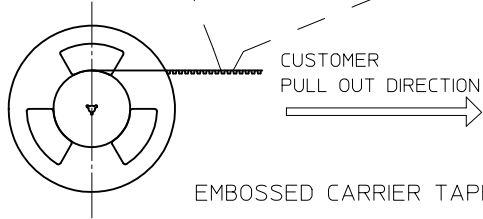
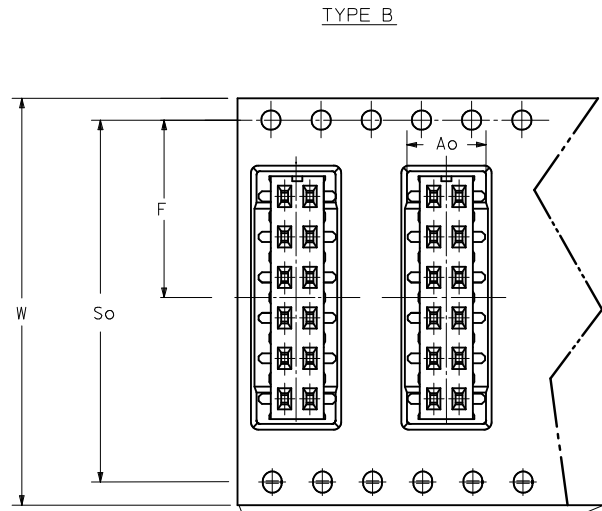
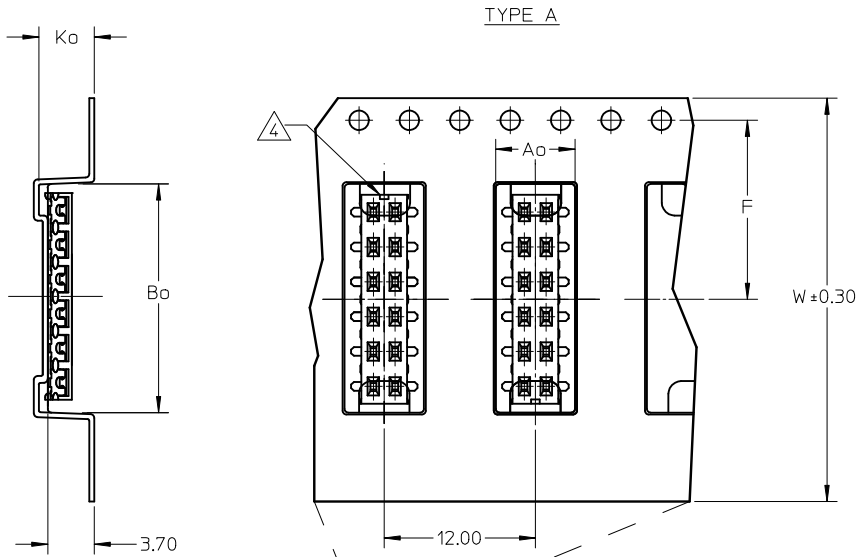

EMBOSSED CARRIER TAPE WITH DIMENSIONS

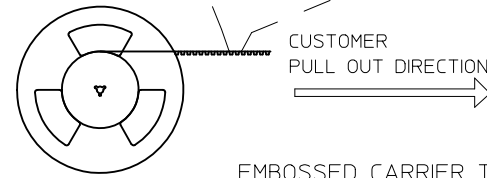

EMBOSSED CARRIER TAPE WITH DIMENSIONS

NOTES:

1. LEADER AND TRAILER TAPE

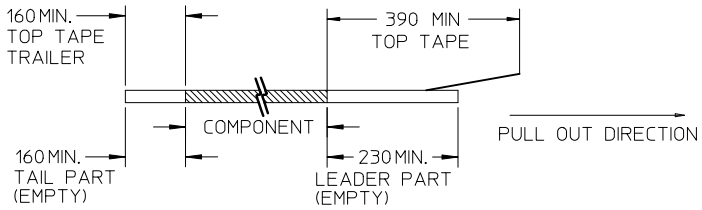

2. PEELING OFF FORCE OF THE TOP TAPE: 20-80gf. (PEELING DIRECTION AS SHOWN IN FOLLOWING FIGURE)

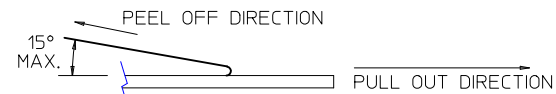

3. PACKAGING STANDARD IS AS PER EIA-481.

4. NO FIX ORIENTATION OF ASSEMBLY PART IN T&R.

5. TAPE & REEL QUANTITY : TBA

ADD T&R OPTION EC NO: S2010-0879 DRWN:SKANG CHKD:ATSEE APPR:MLONG 2010/04/22 2010/04/26 2010/04/27	QUALITY SYMBOLS	GENERAL TOLERANCES (UNLESS SPECIFIED)		DIMENSION STYLE		SCALE	DESIGN UNITS	THIRD ANGLE PROJECTION																
	$\nabla_A = 0$ $\nabla_C = 0$ $\nabla_P = 0$	<table border="1"> <thead> <tr> <th></th> <th>mm</th> <th>INCH</th> </tr> </thead> <tbody> <tr> <td>4 PLACES</td> <td>± ---</td> <td>± ---</td> </tr> <tr> <td>3 PLACES</td> <td>± ---</td> <td>± ---</td> </tr> <tr> <td>2 PLACES</td> <td>± 0.20</td> <td>± ---</td> </tr> <tr> <td>1 PLACE</td> <td>± ---</td> <td>± ---</td> </tr> </tbody> </table>		mm	INCH	4 PLACES	± ---	± ---	3 PLACES	± ---	± ---	2 PLACES	± 0.20	± ---	1 PLACE	± ---	± ---	MM ONLY	NTS	METRIC				
		mm	INCH																					
	4 PLACES	± ---	± ---																					
3 PLACES	± ---	± ---																						
2 PLACES	± 0.20	± ---																						
1 PLACE	± ---	± ---																						
DRAWN BY: JKACHL I CHECKED BY: JNG APPROVED BY: MLONG DATE: 1991/07/02 DATE: 1991/07/09 DATE: 2009/11/24	ANGULAR ± 3 ° DRAFT WHERE APPLICABLE MUST REMAIN WITHIN DIMENSIONS	TITLE: MGRID VLPR II, 2MM DUAL ROW TOP ENTRY RECEPT., SMT MOLEX INCORPORATED DOCUMENT NO. SD-87340-**-01	SHEET NO. 2 OF 3																					
L4	REV	SIZE: A3	THIS DRAWING CONTAINS INFORMATION THAT IS PROPRIETARY TO MOLEX INCORPORATED AND SHOULD NOT BE USED WITHOUT WRITTEN PERMISSION																					

PART NO. IN TUBE	PART NO. TAPE/REEL	CKT SIZE	Ao	Bo	F	W	Ko	So
87340-1014	87340-1019	10	6.70	10.40	11.50	24.00	5.30	-
87340-1613	87340-1618	16	6.60	16.30	11.50	24.00	4.40	-
87340-1424	87340-1429	14	6.60	14.40	11.50	24.00	4.40	-
87340-1813	87340-1818	18	6.60	18.40	14.20	32.00	4.40	28.40
87340-1814	87340-1819	18	6.60	18.40	14.20	32.00	4.40	28.40
87340-2024	87340-2029	20	6.60	20.30	20.20	44.00	5.40	40.40

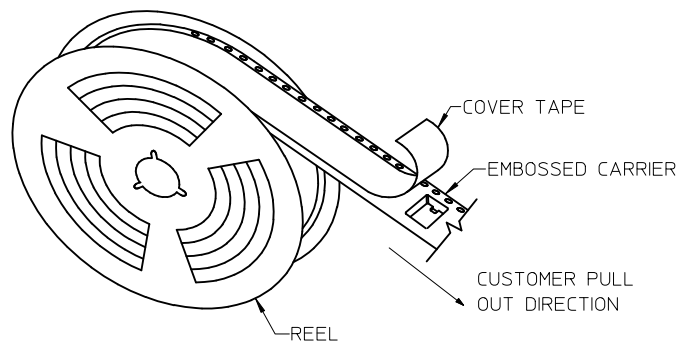

TAPE AND REEL ASSEMBLY SHOWN IS FOR ILLUSTRATION ONLY.

ADD T&R OPTION EC NO: S2010-0879 DRWN:SKANG 2010/04/22 CHKD:ATSEE 2010/04/26 APPR:MLONG 2010/04/27	QUALITY SYMBOLS $F_A=0$ $F_C=0$ $F_P=0$	GENERAL TOLERANCES (UNLESS SPECIFIED) <table border="1"> <thead> <tr> <th></th> <th>mm</th> <th>INCH</th> </tr> </thead> <tbody> <tr> <td>4 PLACES</td> <td>± ---</td> <td>± ---</td> </tr> <tr> <td>3 PLACES</td> <td>± ---</td> <td>± ---</td> </tr> <tr> <td>2 PLACES</td> <td>± 0.20</td> <td>± ---</td> </tr> <tr> <td>1 PLACE</td> <td>± ---</td> <td>± ---</td> </tr> </tbody> </table>		mm	INCH	4 PLACES	± ---	± ---	3 PLACES	± ---	± ---	2 PLACES	± 0.20	± ---	1 PLACE	± ---	± ---	DIMENSION STYLE MM ONLY	SCALE NTS	DESIGN UNITS METRIC	THIRD ANGLE PROJECTION
		mm	INCH																		
	4 PLACES	± ---	± ---																		
	3 PLACES	± ---	± ---																		
2 PLACES	± 0.20	± ---																			
1 PLACE	± ---	± ---																			
		DRAWN BY JKACHL I	DATE 1991/07/02	TITLE MGRID VLPR II, 2MM DUAL ROW TOP ENTRY RECEPT., SMT																	
		CHECKED BY JNG	DATE 1991/07/09	MOLEX MOLEX INCORPORATED																	
		APPROVED BY MLONG	DATE 2009/11/24	MATERIAL NO. SEE TABLE	DOCUMENT NO. SD-87340-**-01	SHEET NO. 3 OF 3															

DRAFT WHERE APPLICABLE
MUST REMAIN
WITHIN DIMENSIONS

SIZE
A3

THIS DRAWING CONTAINS INFORMATION THAT IS PROPRIETARY TO MOLEX INCORPORATED AND SHOULD NOT BE USED WITHOUT WRITTEN PERMISSION

10 9 8 7 6 5 4 3 2 1

PART NO. IN TUBE (REF ONLY) (SEE DRAWING SD-87340-**01)	PART NO. IN TAPE/REEL	CKT. SIZE	DIM. N	DIM. L
87340-1213	87340-1233	12	10.00	12.00

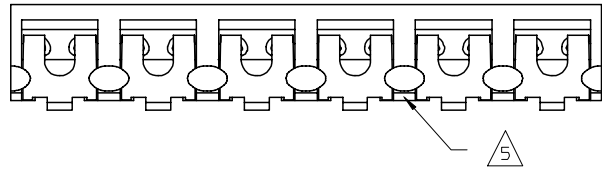
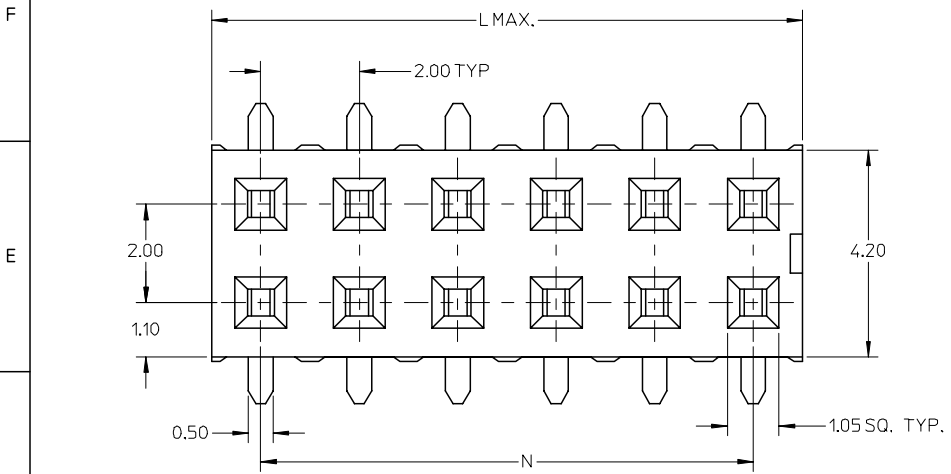

NOTES:

- 12 CIRCUIT SIZE SHOWN FOR ILLUSTRATION ONLY. SEE CHART FOR AVAILABLE PART SIZES IN TAPE & REEL.
- PLATING FINISH :
0.76um/30uin MIN. GOLD IN CONTACT AREA
1.27um/50uin MIN. TIN IN SOLDER TAIL AREA
BOTH OVER 1.90um/75uin MIN. NICKEL OVERALL.
- COPLANARITY OF SOLDER TAIL IS TO BE MEASURED BY RESTING THE PART ON A FLAT GAUGE SURFACE.
- PRODUCT SPECIFICATION PS-87340 APPLIES.
- THIS AREA OF PART TO BE HEAT STAKED TO RETAIN CONTACTS.
- PART IS MATEABLE TO ALL MILLI-GRID HEADERS WITH MINIMUM PIN LENGTHS OF 1.90mm FOR TOP ENTRY.

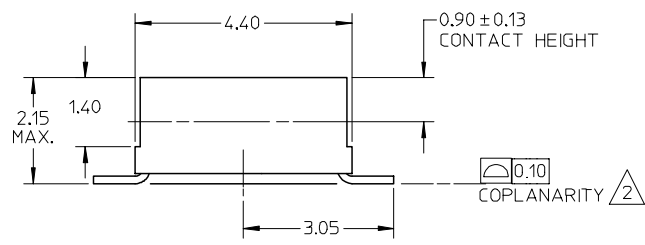

PART NO. LEGEND

87340 - * * * 3

CIRCUIT SIZE

3 - WITHOUT LOCATING PEGS IN TAPE AND REEL

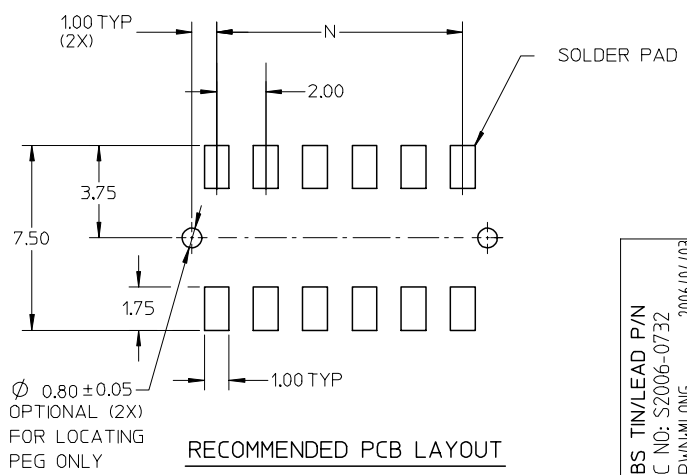

OBS TIN/LEAD P/N	2006/04/03
EC NO: S2006-0732	2006/04/04
DRWN:MLG	2006/04/04
CHKD:NAGESHKN	2006/04/05
APPR:PTLIM	2006/04/05

QUALITY SYMBOLS	DESCRIPTION
▽=0	
▽=0	

GENERAL TOLERANCES (UNLESS SPECIFIED)	
	mm INCH
4 PLACES	± --- ± ---
3 PLACES	± --- ± ---
2 PLACES	± 0.20 ± ---
1 PLACE	± --- ± ---
ANGULAR ± 3 °	
DRAFT WHERE APPLICABLE MUST REMAIN WITHIN DIMENSIONS	

DIMENSION STYLE		SCALE		DESIGN UNITS		THIRD ANGLE PROJECTION	
MM ONLY		NTS		METRIC		⊙ □	
DRAWN BY	DATE	TITLE					
EP0H	1993/10/07						
CHECKED BY	DATE						
EDPOH	1993/10/18						
APPROVED BY	DATE						
RWONG	1993/10/18						
MATERIAL NO.		DOCUMENT NO.		SHEET NO.			
SEE TABLE		SD-87340-**3*		1 OF 2			

MGRID
VLPR II, 2MM DUAL ROW
TOP ENTRY RECEPT., SMT

MOLEX INCORPORATED

THIS DRAWING CONTAINS INFORMATION THAT IS PROPRIETARY TO MOLEX INCORPORATED AND SHOULD NOT BE USED WITHOUT WRITTEN PERMISSION

9 8 7 6 5 4 3 2 1

10 9 8 7 6 5 4 3 2 1

PART NO. TAPE/REEL	CKT SIZE	Ao	Bo	F	W	Ko
87340-1233	12	6.65	12.50	11.50	24.00	2.95

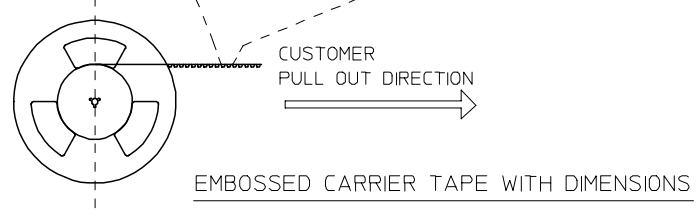
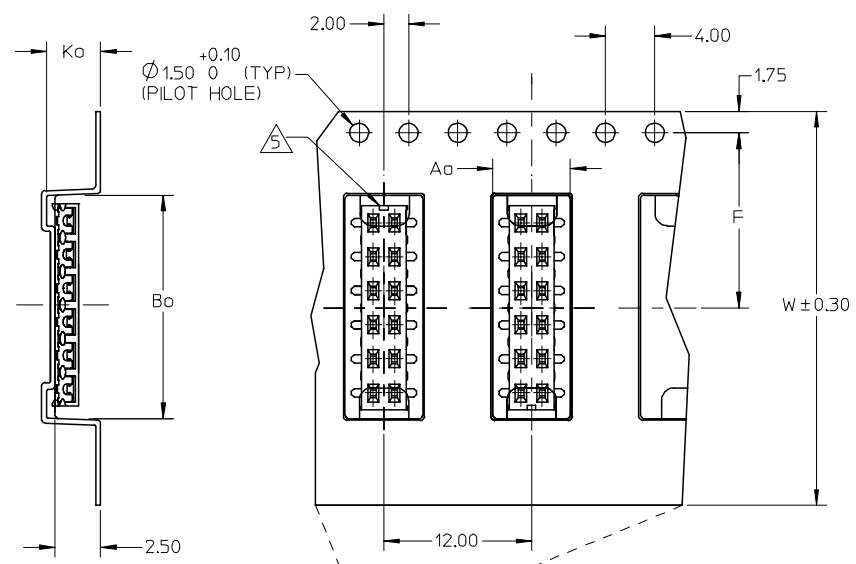

NOTES:

- LEADER AND TRAILER TAPE
- PEELING OFF FORCE OF THE TOP TAPE: 20-80gf.
 (PEELING DIRECTION AS SHOWN IN FOLLOWING FIGURE)
- PACKAGING STANDARD IS AS PER EIA-481.
- TAPE & REEL QUANTITY = 1500 PCS/REEL
- NO FIX ORIENTATION OF ASSEMBLY PART IN T&R.

TAPE AND REEL ASSEMBLY SHOWN IS FOR ILLUSTRATION ONLY.

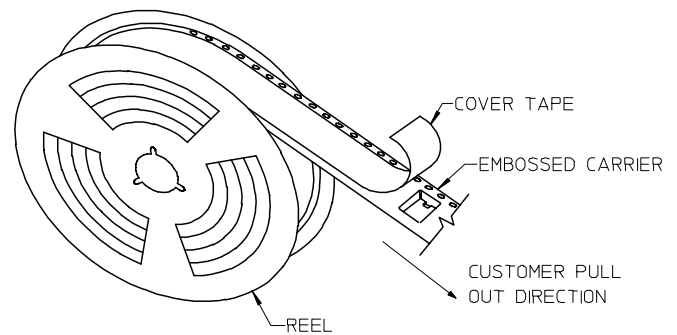

OBS TIN/LEAD P/N EC NO: S2006-0732 DRWN:MLONG CHKD:NAGESHKN APPR:PTLIM	QUALITY SYMBOLS ▽=0 ▽=0	GENERAL TOLERANCES (UNLESS SPECIFIED)	DIMENSION STYLE MM ONLY	SCALE NTS	DESIGN UNITS METRIC	THIRD ANGLE PROJECTION
		4 PLACES ± --- ± --- 3 PLACES ± --- ± --- 2 PLACES ± 0.20 ± --- 1 PLACE ± --- ± --- ANGULAR ± 3 °	DRAWN BY EP0H CHECKED BY EDPOH APPROVED BY RWONG	DATE 1993/10/07 DATE 1993/10/18 DATE 1993/10/18	TITLE MGRID VLPR II, 2MM DUAL ROW TOP ENTRY RECEPT., SMT	MOLEX INCORPORATED
REV	DESCRIPTION	DRAFT WHERE APPLICABLE MUST REMAIN WITHIN DIMENSIONS	MATERIAL NO. SEE TABLE	DOCUMENT NO. SD-87340-**3*	SHEET NO. 2 OF 2	

9 8 7 6 5 4 3 2 1