

# DC-AC INVERTER UNIT

PS-DA0253-01-E-B (9 W DUAL OUTPUTS)

(PRELIMINARY INFORMATION)

**DESCRIPTION :**

This DC to AC Inverter was developed for many other low LCD Backlight power supply as low profile applications.  
**Optimized for Sharp: LQ080Y5DR02**

**APPLICABLE LCD:**

- 10 to 15 inches dual lamp type
- Lamp Voltage 470 Vrms
- Lamp Current 2 x 5.0 mArms
- Lamp Start Up Voltage 1.800 Vrms (Vin : 12 Vdc)



**FEATURES :**

- Current Feedback Circuit
- High Efficiency
- Low noise with voltage resonant circuit
- Regulated output current

**TEMPERATURE & HUMDITY :**

- Operating Temperature Range -30°C ~ +85°C (for Sharp LQ080Y5DR02 only, for other display please request factory)
- Storage Temperature Range -35°C ~ +85°C
- Humidity 95 %RH max

**DIMENSIONS :**

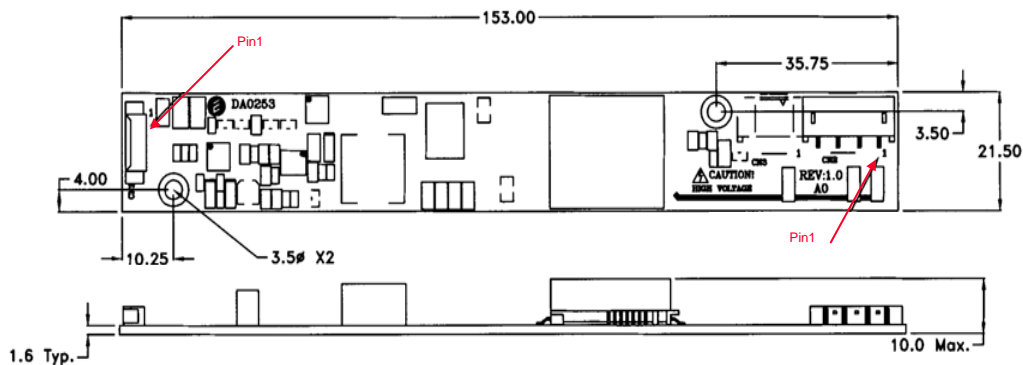

Unit : mm  
 Weight :40 (g) typ.

**Components**

No.	Part Discription	Qty.	Material	Note
1	PCB	1	UL94V-0 (FR-4 or CEM-3)	t=1mm
2	Connector CN1	1	53261-0790	Molex or equal
3	Connector CN2	1	SM04(4.0)B-BHS-1-TB	JST or equal

**Input side CN1:**

Pin No.	Symbols	Ratings
CN 1-1+2	Vin	10.8 ~ 13.2 Vdc
CN 1-3+4	GND	
CN 1-5	Vrmt	0 ~ 0.4 = OFF / 2.5 ~ Vin = ON
CN 1-6	Vbr	0 ~ 1.8 Vdc
CN 1-7	Vbr	0 ~ 10kOhm

**Output side CN2**

Pin No.	Symbols	Ratings
CN 2-1	Vhigh	470 Vrms (5.0 mArms)
CN 2-2	Vhigh	470 Vrms (5.0 mArms)
CN 2-3	N.C.	-
CN 2-4	Vlow	(GND)

**Power Systems – The Power Solution**

Web: [www.Power-Systems.de](http://www.Power-Systems.de)  
 Email: [Info@Power-Systems.de](mailto:Info@Power-Systems.de)

Address: Dörnet 8 ; 74360 Ilsfeld-Auenstein / Germany  
 Tel. : + 49 / 70 62 / 67 59 - 6  
 Fax: + 49 / 70 62 / 67 59 - 800

# DC-AC INVERTER UNIT

PS-DA0253-01-E-B (9 W DUAL OUTPUTS)

(PRELIMINARY INFORMATION)

## ELECTRICAL CHARACTERISTICS :

Parameters	Symbols	Conditions			Specification			Unit	Note
		Vin (V)	Vrmt (V)	Tu (°C)	Min.	Typ.	Max.		
Output Current	Iout	12±1.2	5±0.25	0 ~ +50	4.5	5.0	5.5	mArms	Duty 100%
Output Current	Iout	12±0.6	5±0.25	0 ~ +50	1.7	2.0	2.4	mArms	Vbr = 1.8Vdc
Input Current	Iin	12±1.2	5±0.25	0 ~ +50	-	0.75	1.0	Adc	
Frequency	F	12±1.2	5±0.25	0 ~ +50	32.5	40	47.5	kHz	
Open Circuit Voltage	Vopen	11.4	5±0.25	0 ~ +50	1.500	1.800	1.900	Vrms	
No Load Shutdown	Tsd	12±1.2	5±0.25	0 ~ +50	-	1.0	-	sec	without load

Note 1 : Please keep minimum of 2mm clearance (all directions) between inverter high voltage area as marked on mechanical drawing and any conductors.

## DIMMING CHARACTERISTICS (Reference)

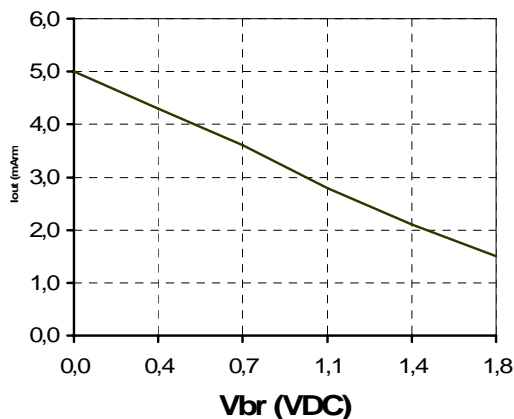

## TEST CIRCUIT :

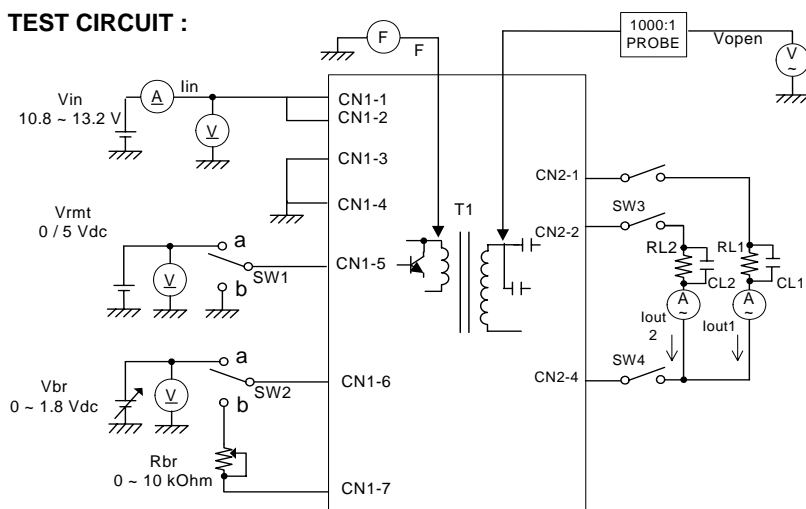

SW1	Operation of unit
a	Operation
b	Non operation

SW2	Operation of unit
a	Vbr 0 ~ 1.8 Vdc dimming
b	Rbr 0 ~ 10 kOhm dimming

## Power Systems – The Power Solution

Web: [www.Power-Systems.de](http://www.Power-Systems.de)  
 Email: [Info@Power-Systems.de](mailto:Info@Power-Systems.de)

Address: Dörnet 8 ; 74360 Ilsfeld-Auenstein / Germany  
 Tel. : + 49 / 70 62 / 67 59 - 6  
 Fax: + 49 / 70 62 / 67 59 - 800