



SAW TECHNOLOGY CO., LTD.

No. 3, Industrial 2nd Rd., Ping-Chen Industrial District,
Taoyuan, 324, Taiwan, R.O.C.

TEL: 886-3-4690038 FAX: 886-3-4697532

E-mail: tstsales@mail.taisaw.com Web: www.taisaw.com

Product Specifications Approval Sheet

Product Description: SAW Filter 120MHz SMD 13.3x6.5

TST Part No.: TB0763A

Customer Part No.: _____

Customer signature required
Company: _____
Division: _____
Approved by : _____
Date: _____

Checked by: _____ Ricky Lee *Ricky*

Approved by: _____ Francis Chen *Francis*

Date: _____ 2009/05/014

1. Customer signed back is required before TST can proceed with sample build and receive orders.
2. Orders received without customer signed back will be regarded as agreement on the specifications.
3. Any specifications changes must be approved upon by both parties and a new revision of specifications shall be released to reflect the changes.



TAI-SAW TECHNOLOGY CO., LTD.

No. 3, Industrial 2nd Rd., Ping-Chen Industrial District,
Taoyuan, 324, Taiwan, R.O.C.

TEL: 886-3-4690038 FAX: 886-3-4697532

E-mail: tstsales@mail.taisaw.com Web: www.taisaw.com

IF SAW Filter 120MHz(BW=15MHz) SMD 13.3X6.5mm

MODEL NO.: TB0763A

REV.1.0

A. MAXIMUM RATING:

1. Operating Temperature: -20 °C ~ +80 °C
2. Storage Temperature: -40 °C ~ +85 °C
3. Input power: 10dBm

RoHS Compliant
Lead free
Lead-free soldering

B. Characteristics :

Ambient Temperature: 25 °C

Characteristics	Value			Note
	Min.	Typ.	Max.	
Center frequency F_c MHz	-	120.0	-	-
Minimum Insertion loss I.L. dB	-	17.0	20.0	-
1.5dB BW MHz	15.0	17	-	
Rejection at $F_c \pm 13$ MHz MHz	40.0	46.0	-	
Passband Ripple $F_c \pm 7.5$ MHz dB	-	0.85	1.0	-
Group-Delay Ripple $F_c \pm 7.5$ MHz nsec	-	100	120	-
Phase Linearity $F_c \pm 7.5$ MHz p-p deg	-	11	13	
Rejection				
10~100MHz dBc	45	52	-	-
140~180MHz dBc	40	47	-	-
Temp Coefficient ppm/K	-	-94	-	-
Matching:				
1.The input of the filter will be matched to <u>50 ohm</u>				
2.The output of the filter will be matched to <u>50 ohm</u>				

C. Frequency Characteristics :

1. S21 Response: (span : 100MHz)

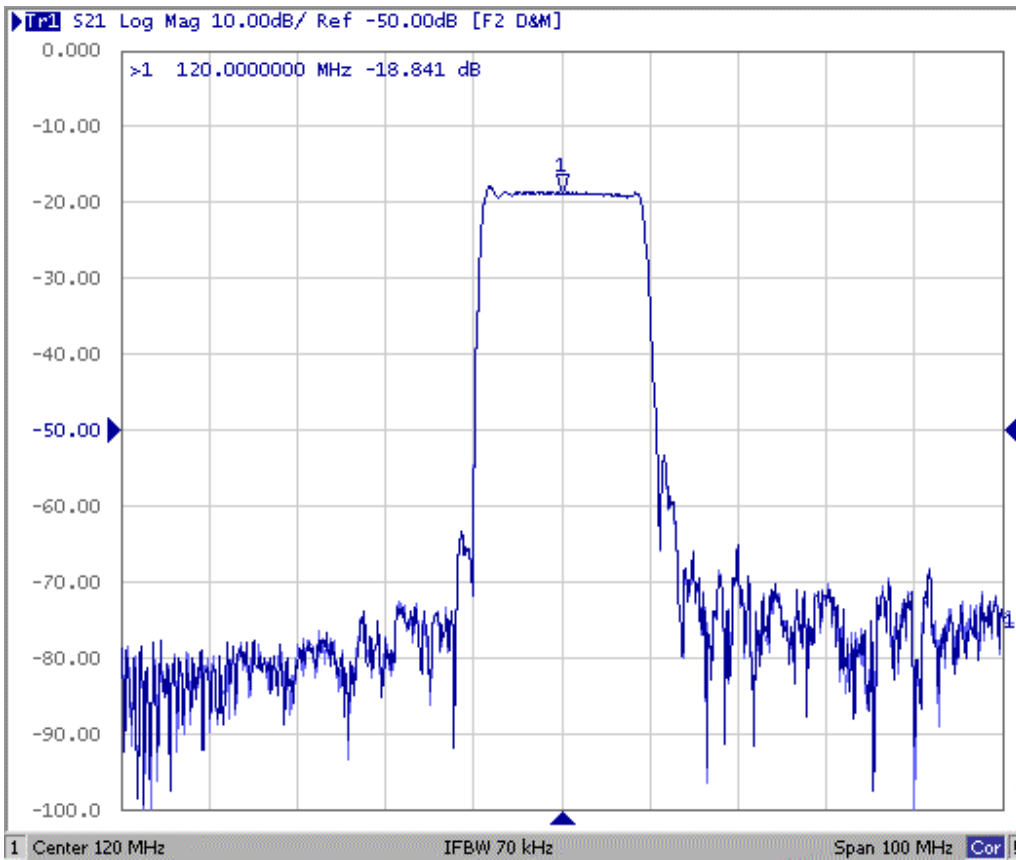

Fig1. Horizontal: 10MHz/Div Vertical: 10dB/Div

2. Group-Delay Ripple: (span : 30MHz)

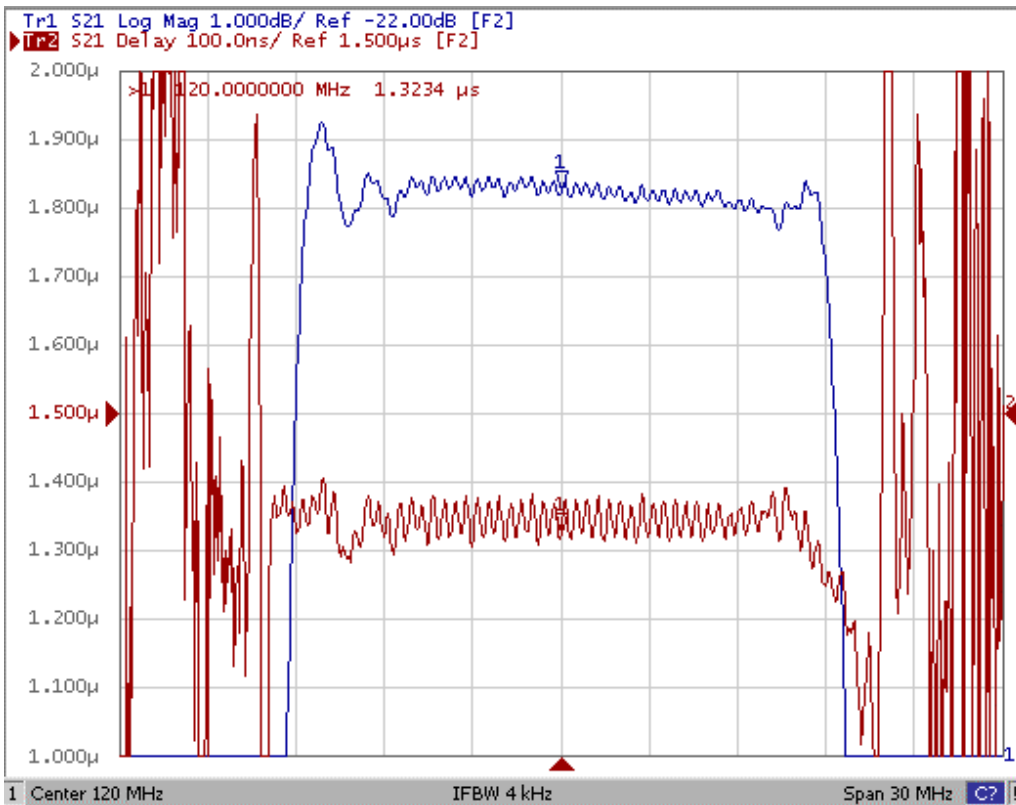
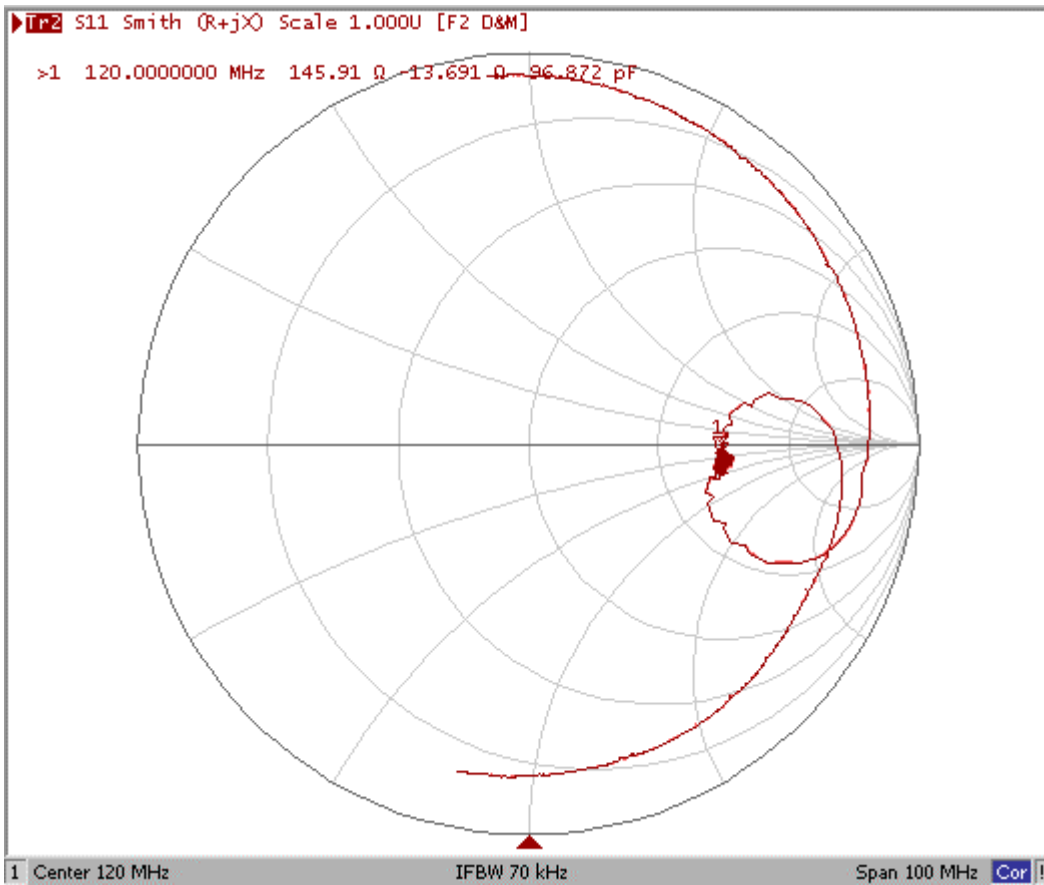
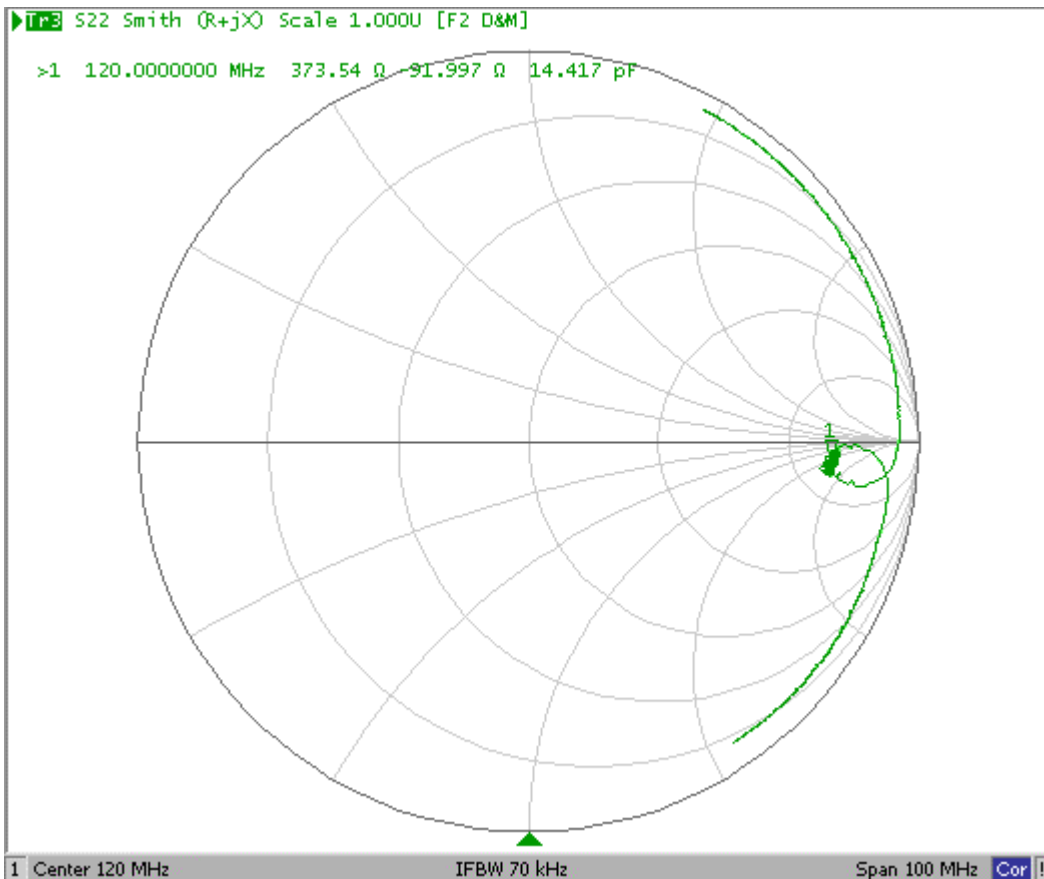

Fig2. Horizontal: 3MHz/Div Vertical: 100ns

3. S11 Smith Chart: (span : 100MHz)



4. S22 Smith Chart (span : 100MHz)



D. Measurement Circuit:

Matching Circuit

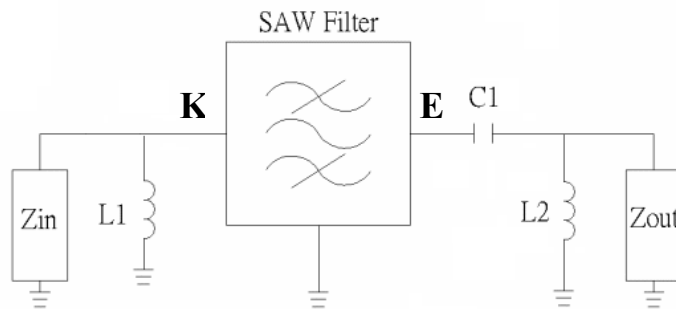

Z_{in} and Z_{out} are $50\ \Omega$.

$L1=68\text{ nH}, C1=82\text{ pF}, L2=120\text{ nH}$

E. Outline Drawing:

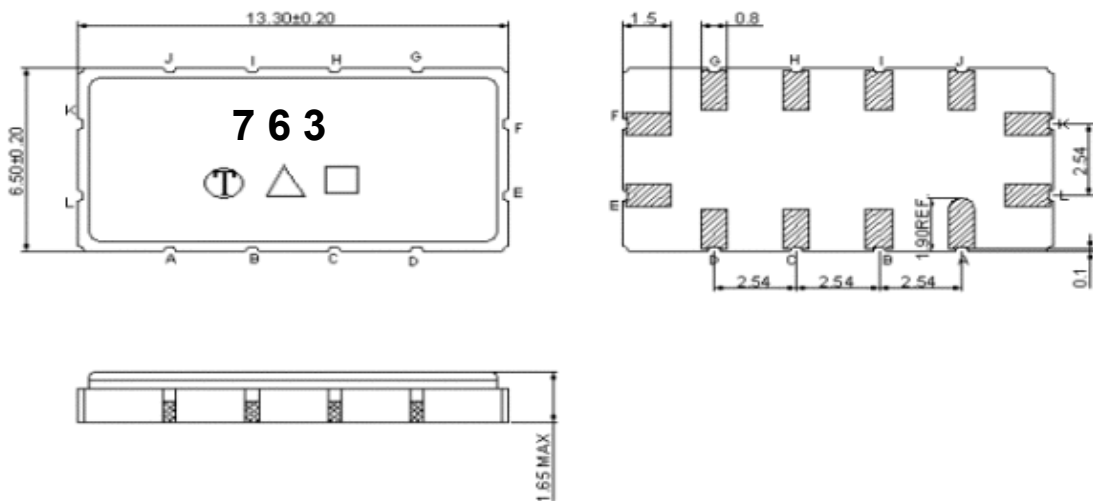

Pin K: RF input

Pin E: RF output

Pin A, B, C, D, G, H, I, L, F, J: To be Ground

□ : Week Code (Follow the table from planner each year)

Unit : mm (week01, 02, 03...52 =>A, B, C...z)

△ : Product / Year Code

Year	2005 2009	2006 2010	2007 2011	2008 2012
Product Code	B	b	<u>B</u>	<u>b</u>

F. PCB Footprint:

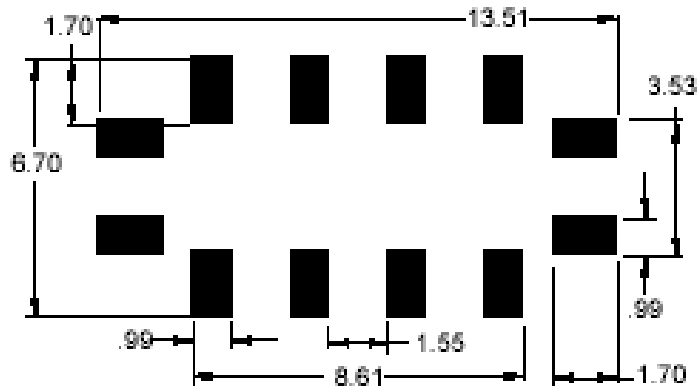

Unit: mm

H. PACKING:

1. REEL DIMENSION

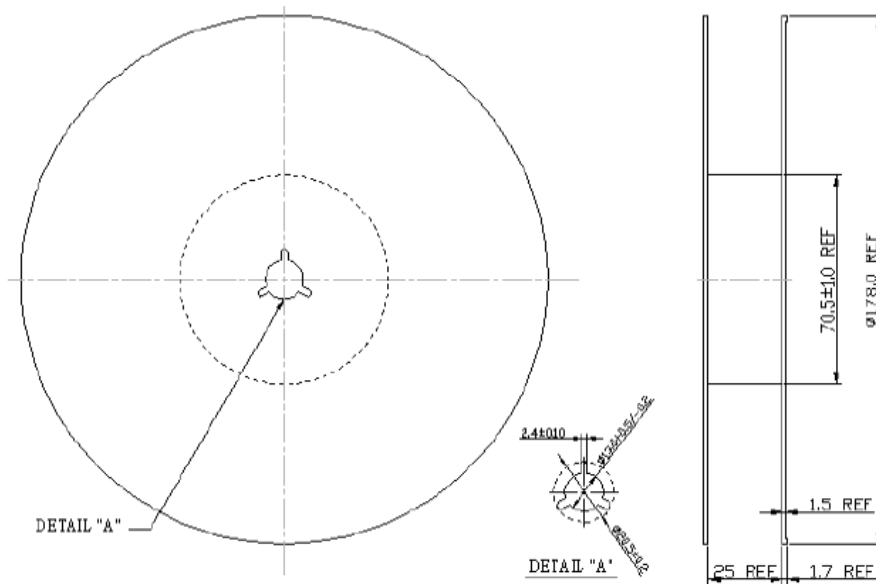

Unit: mm

2. TAPE DIMENSION

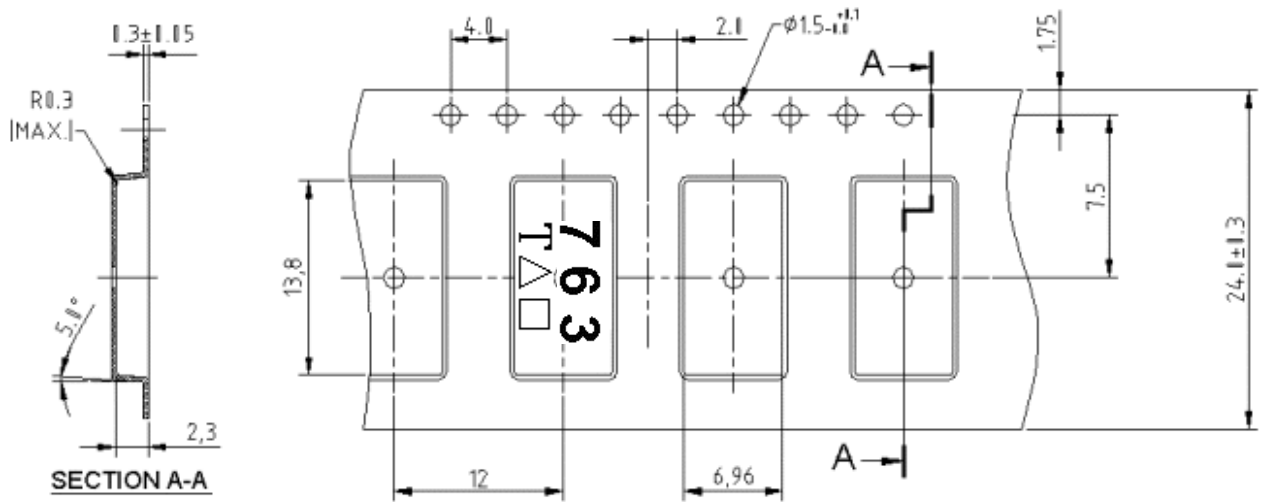

Unit: mm

I. RECOMMENDED REFLOW PROFILE :

