

Features

- **maXTouch™ Touchscreen**
 - True 12-bit multi-touch with independent XY tracking for up to 10 concurrent touches in real time with touch size reporting
 - Up to 4.3 inch diagonal screen size supported with 10 mm “pinch” separation
 - Up to 10.1 inch support with correspondingly wider “pinch”
- **Number of Channels**
 - Up to 224 (subject to other configuration limitations)
 - Electrode grid configurations up to 20 X by 10 Y lines supported (subject to 30 total pins and a maximum of 14 Y lines)
- **maXTouch Touch Key Support**
 - Up to 32 channels can be allocated as fixed keys (subject to other configurations)
- **Zero Additional Part Count**
 - 16 X by 14 Y matrix (224 channels) implementable with power bypass capacitors only
- **Signal Processing**
 - Advanced digital filtering using both hardware engine and firmware
 - Self-calibration
 - Auto drift compensation
 - Adjacent Key Suppression® (AKS™) technology
 - Grip and face suppression
 - Reports one-touch and two-touch gestures
 - Down-scaling and clipping support to match LCD resolution
 - Ultra-fast start-up and calibration for best user experience
 - Supports axis flipping and axis switch-over for portrait and landscape modes
- **Scan Speed**
 - Maximum single touch >250Hz, subject to configuration
 - Configurable to allow power/speed optimization
 - Programmable timeout for automatic transition from active to idle states
- **Response Times**
 - Initial latency <10 ms for first touch from idle, subject to configuration
- **Sensors**
 - Works with PET or glass sensors
 - Works with all proprietary sensor patterns recommended by Atmel®
 - Works with passive stylus
- **Panel Thickness**
 - Glass up to 3 mm, screen size dependent
 - Plastic up to 1.5 mm, screen size dependent
- **Interface**
 - I²C-compatible slave mode 400 kHz
- **Dual-rail Power**
 - Interface 1.8V to 3.3V nominal, analog 2.7V to 3.3V nominal
- **Power Consumption**
 - Idle 80Hz: <1.8 mW, subject to configuration
 - One Touch Active 80Hz: 3.9 mW, subject to configuration
 - Sleep: 4.5 μW
- **Package**
 - 49-ball UFBGA 5 x 5 x 0.6 mm, 0.65 ball pitch
 - 49-ball VFBGA 5 x 5 x 1 mm, 0.65 ball pitch
 - 48-pin QFN 6 x 6 x 0.6 mm, 0.4 mm pin pitch



maXTouch™ 224-channel Touchscreen Sensor IC

mXT224

Summary

Note: This is a summary document. A complete document is available under NDA. For more information contact www.atmel.com/touchscreen.

maXTouch™

9530BS-AT42-10/09



1. Pinout and Schematic

1.1 Pinout Configuration

1.1.1 49-ball UFBGA/VFBGA

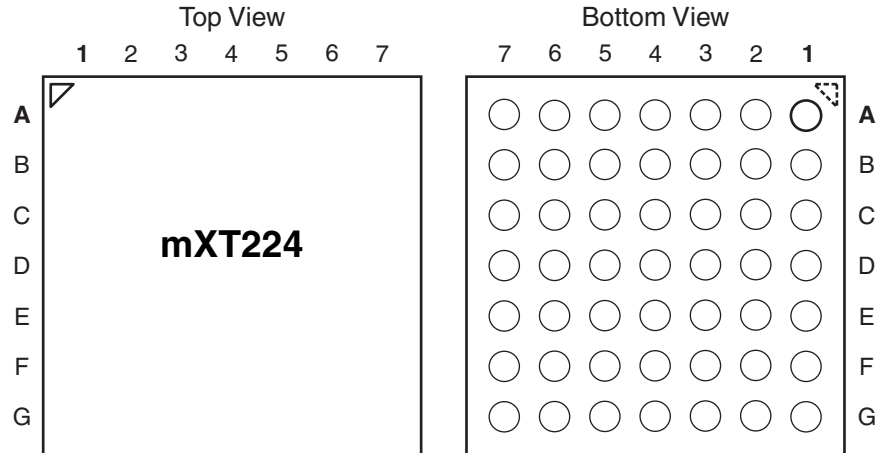

1.1.2 48-pin QFN

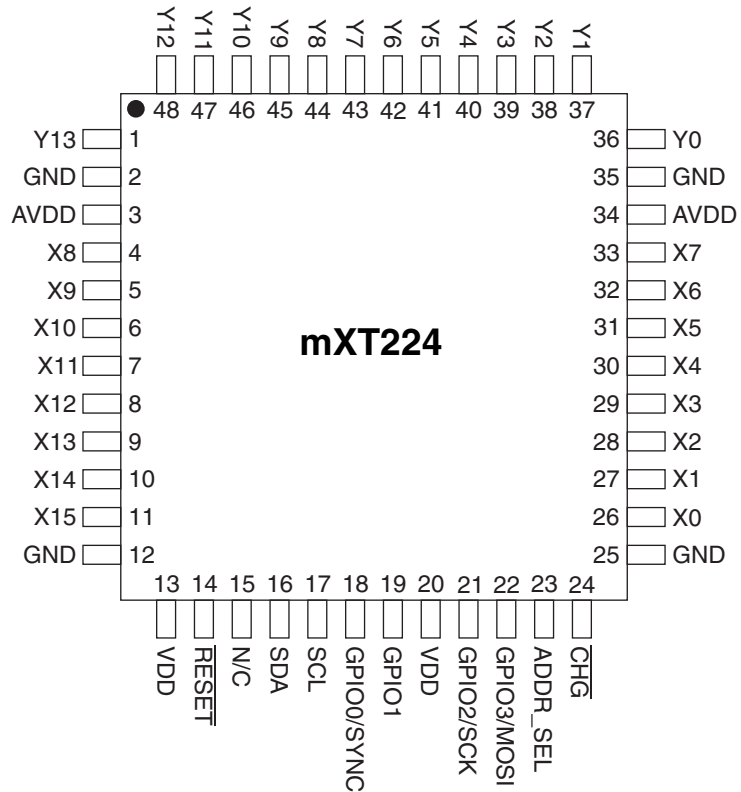

1.2 Pinout Descriptions

1.2.1 49-ball UFBGA/VFBGA

Table 1-1. Pin Listing

Ball	Name	Type	Comments	If Unused, Connect To...
A1	AVDD	P	Analog power	–
A2	Y12	I/O	Y line connection or X line in extended mode	Leave open
A3	Y10	I/O	Y line connection or X line in extended mode	Leave open
A4	Y8	I	Y line connection	Leave open
A5	Y6	I	Y line connection	Leave open
A6	Y4	I	Y line connection	Leave open
A7	Y2	I	Y line connection	Leave open
B1	X8	O	X matrix drive line	Leave open
B2	GND	P	Ground	–
B3	Y11	I/O	Y line connection or X line in extended mode	Leave open
B4	Y9	I	Y line connection	Leave open
B5	Y5	I	Y line connection	Leave open
B6	Y1	I	Y line connection	Leave open
B7	Y0	I	Y line connection	Leave open
C1	X10	O	X matrix drive line	Leave open
C2	X9	O	X matrix drive line	Leave open
C3	Y13	I/O	Y line connection or X line in extended mode	Leave open
C4	Y7	I	Y line connection	Leave open
C5	Y3	I	Y line connection	Leave open
C6	GND	P	Ground	–
C7	AVDD	P	Analog power	–
D1	X12	O	X matrix drive line	Leave open
D2	X13	O	X matrix drive line	Leave open
D3	X11	O	X matrix drive line	Leave open
D4	GND	P	Ground	–
D5	X7	O	X matrix drive line	Leave open
D6	X5	O	X matrix drive line	Leave open
D7	X6	O	X matrix drive line	Leave open
E1	X14	O	X matrix drive line	Leave open
E2	X15	O	X matrix drive line	Leave open
E3	$\overline{\text{RESET}}$	I	Reset low; has internal 30 k Ω to 60 k Ω pull-up resistor	Leave open or Vdd
E4	GPIO1	I/O	General purpose I/O	Input: GND Output: leave open

Table 1-1. Pin Listing (Continued)

Ball	Name	Type	Comments	If Unused, Connect To...
E5	X1	O	X matrix drive line	Leave open
E6	X3	O	X matrix drive line	Leave open
E7	X4	O	X matrix drive line	Leave open
F1	VDD	P	Digital power	–
F2	GND	P	Ground	–
F3	SCL	OD	Serial Interface Clock	–
F4	GPIO3/ MOSI	I/O	General purpose I/O / Debug data	Input: GND Output: leave open
F5	GND	P	Ground	–
F6	$\overline{\text{CHG}}$	OD	State change interrupt	–
F7	X2	O	X matrix drive line	Leave open
G1	N/C	–	No connection	Leave open
G2	SDA	OD	Serial Interface Data	–
G3	GPIO0/ SYNC	I/O	General purpose I/O External synchronization	Input: GND Output: leave open
G4	GPIO2/ SCK	I/O	General purpose I/O / Debug clock	Input: GND Output: leave open
G5	VDD	P	Digital power	–
G6	ADDR_SEL	I	I ² C-compatible address select	–
G7	X0	O	X matrix drive line	Leave open

I Input only
 O Output only, push-pull
 P Ground or power

I/O Input and output
 OD Open drain output

1.2.2 48-pin QFN

Table 1-2. Pin Listing

Pin	Name	Type	Comments	If Unused, Connect To...
1	Y13	I/O	Y line connection or X line in extended mode	Leave open
2	GND	P	Ground	–
3	AVDD	P	Analog power	–
4	X8	O	X matrix drive line	Leave open
5	X9	O	X matrix drive line	Leave open
6	X10	O	X matrix drive line	Leave open
7	X11	O	X matrix drive line	Leave open
8	X12	O	X matrix drive line	Leave open
9	X13	O	X matrix drive line	Leave open
10	X14	O	X matrix drive line	Leave open
11	X15	O	X matrix drive line	Leave open
12	GND	P	Ground	–
13	VDD	P	Digital power	–
14	$\overline{\text{RESET}}$	I	Reset low; has internal 30 k Ω to 60 k Ω pull-up resistor	Leave open or Vdd
15	N/C	–	No connection	Leave open
16	SDA	OD	Serial Interface Data	–
17	SCL	OD	Serial Interface Clock	–
18	GPIO0/ SYNC	I/O	General purpose I/O External synchronization	Input: GND Output: leave open
19	GPIO1	I/O	General purpose I/O	Input: GND Output: leave open
20	VDD	P	Digital power	–
21	GPIO2/ SCK	I/O	General purpose I/O / Debug clock	Input: GND Output: leave open
22	GPIO3/ MOSI	I/O	General purpose I/O / Debug data	Input: GND Output: leave open
23	ADDR_SEL	I	I ² C-compatible address select	–
24	$\overline{\text{CHG}}$	OD	State change interrupt	–
25	GND	P	Ground	–
26	X0	O	X matrix drive line	Leave open
27	X1	O	X matrix drive line	Leave open
28	X2	O	X matrix drive line	Leave open
29	X3	O	X matrix drive line	Leave open
30	X4	O	X matrix drive line	Leave open
31	X5	O	X matrix drive line	Leave open
32	X6	O	X matrix drive line	Leave open

Table 1-2. Pin Listing (Continued)

Pin	Name	Type	Comments	If Unused, Connect To...
33	X7	O	X matrix drive line	Leave open
34	AVDD	P	Analog power	–
35	GND	P	Ground	–
36	Y0	I	Y line connection	Leave open
37	Y1	I	Y line connection	Leave open
38	Y2	I	Y line connection	Leave open
39	Y3	I	Y line connection	Leave open
40	Y4	I	Y line connection	Leave open
41	Y5	I	Y line connection	Leave open
42	Y6	I	Y line connection	Leave open
43	Y7	I	Y line connection	Leave open
44	Y8	I	Y line connection	Leave open
45	Y9	I	Y line connection	Leave open
46	Y10	I/O	Y line connection or X line in extended mode	Leave open
47	Y11	I/O	Y line connection or X line in extended mode	Leave open
48	Y12	I/O	Y line connection or X line in extended mode	Leave open

I Input only
 O Output only, push-pull
 P Ground or power

I/O Input and output
 OD Open drain output

1.3 Schematic

1.3.1 49-ball UFBGA/VFBGA

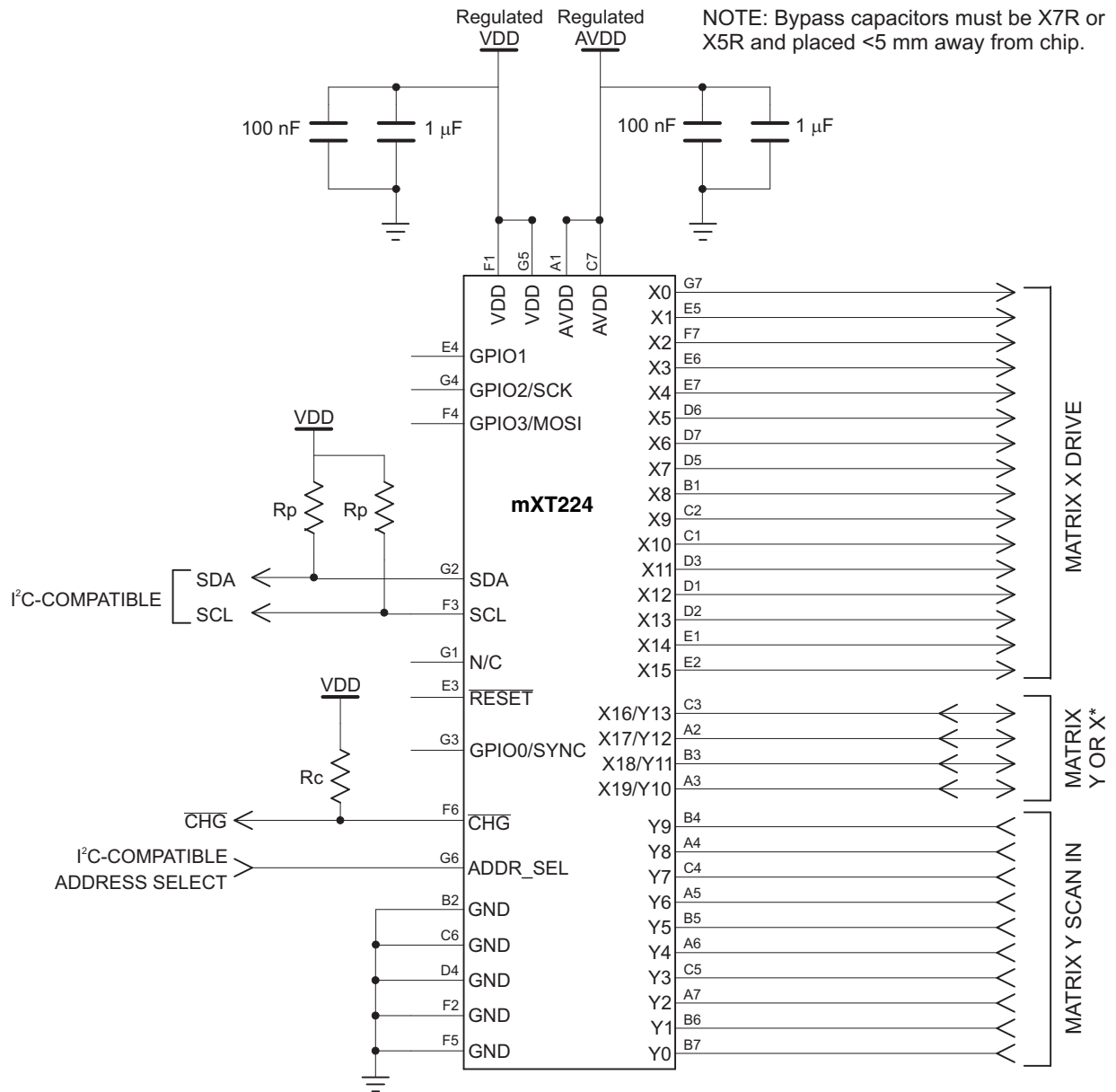

* NOTE: Y10 to Y13 scan lines may be used as additional X drive lines in extended mode (a 100Ω resistor must be added to each additional line).

1.3.2 48-pin QFN

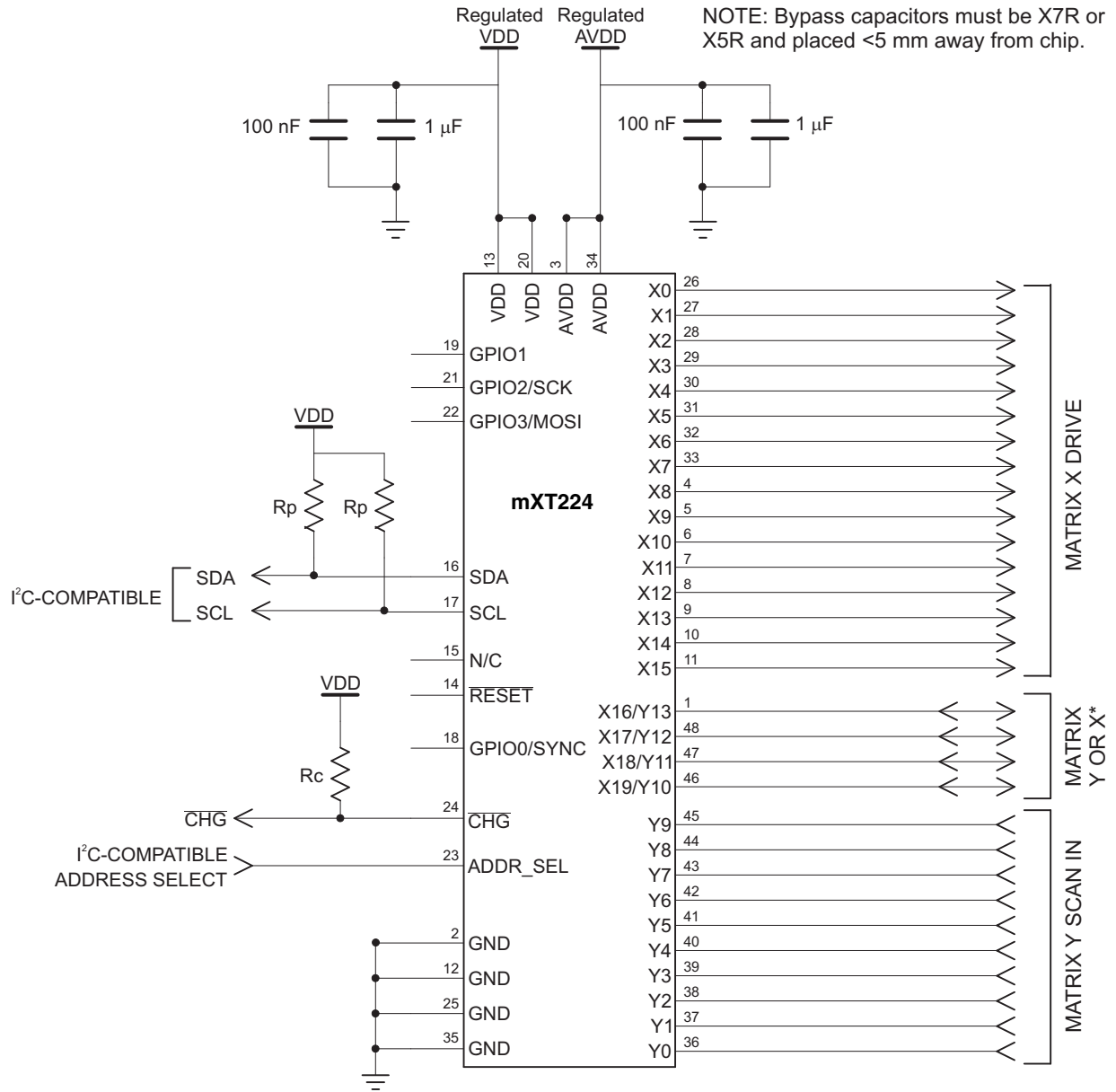

* NOTE: Y10 to Y13 scan lines may be used as additional X drive lines in extended mode (a 100Ω resistor must be added to each additional line).

2. Overview of the mXT224

2.1 Introduction

The mXT224 (AT42QT602240) uses a unique charge-transfer acquisition engine to implement the QMatrix™ capacitive sensing method patented by Atmel®. This allows the measurement of up to 224 mutual capacitance nodes in under 1 ms. Coupled with a state-of-the-art XMEGA™ CPU, the entire touchscreen sensing solution can measure, classify and track a single finger touch every 4 ms if required.

The acquisition engine uses an optimal measurement approach to ensure almost complete immunity from parasitic capacitance on the receiver inputs (Y lines). The engine includes sufficient dynamic range to cope with touchscreen mutual capacitances spanning 0.5 pF to 5 pF, allowing great flexibility for use with Atmel's proprietary ITO pattern designs. One and two layer ITO sensors are possible using glass or PET substrates.

The main AVR® XMEGA CPU has, under its control, two powerful, yet low power, microsequencer coprocessors. These combine to allow the signal acquisition, preprocessing, postprocessing and housekeeping to be partitioned in an efficient and flexible way. This gives ample scope for sensing algorithms, touch tracking or advanced shape-based filtering. An in-circuit reflash can be performed over the chip's hardware-driven two-wire interface (I²C-compatible).

Overall, the mXT224 represents a step improvement over competing technologies, providing a near optimal mix of low power, small size and low part count, while offering unrivalled true multitouch performance.



Revision History

Revision Number	History
Revision AS – September 2009	Initial release for chip revision 1.4
Revision BS – October 2009	QFN package details added

Notes



Headquarters

Atmel Corporation
2325 Orchard Parkway
San Jose, CA 95131
USA
Tel: 1(408) 441-0311
Fax: 1(408) 487-2600

International

Atmel Asia
Unit 01-05 & 16, 19/F
BEA Tower, Millennium City 5
418 Kwun Tong Road
Kwun Tong
Kowloon
Hong Kong
Tel: (852) 2245-6100
Fax: (852) 2722-1369

Atmel Europe
Le Krebs
8, Rue Jean-Pierre Timbaud
BP 309
78054 Saint-Quentin-en-
Yvelines Cedex
France
Tel: (33) 1-30-60-70-00
Fax: (33) 1-30-60-71-11

Atmel Japan
9F, Tonetsu Shinkawa Bldg.
1-24-8 Shinkawa
Chuo-ku, Tokyo 104-0033
Japan
Tel: (81) 3-3523-3551
Fax: (81) 3-3523-7581

Touch Technology Division

1 Mitchell Point
Ensign Way
Hamble
Southampton
Hampshire SO31 4RF
United Kingdom
Tel: (44) 23-8056-5600
Fax: (44) 23-8045-3939

Product Contact

Web Site
www.atmel.com

Technical Support
touch@atmel.com

Sales Contact
www.atmel.com/contacts

Literature Requests
www.atmel.com/literature

Disclaimer: The information in this document is provided in connection with Atmel products. No license, express or implied, by estoppel or otherwise, to any intellectual property right is granted by this document or in connection with the sale of Atmel products. **EXCEPT AS SET FORTH IN ATMEL'S TERMS AND CONDITIONS OF SALE LOCATED ON ATMEL'S WEB SITE, ATMEL ASSUMES NO LIABILITY WHATSOEVER AND DISCLAIMS ANY EXPRESS, IMPLIED OR STATUTORY WARRANTY RELATING TO ITS PRODUCTS INCLUDING, BUT NOT LIMITED TO, THE IMPLIED WARRANTY OF MERCHANTABILITY, FITNESS FOR A PARTICULAR PURPOSE, OR NON-INFRINGEMENT. IN NO EVENT SHALL ATMEL BE LIABLE FOR ANY DIRECT, INDIRECT, CONSEQUENTIAL, PUNITIVE, SPECIAL OR INCIDENTAL DAMAGES (INCLUDING, WITHOUT LIMITATION, DAMAGES FOR LOSS OF PROFITS, BUSINESS INTERRUPTION, OR LOSS OF INFORMATION) ARISING OUT OF THE USE OR INABILITY TO USE THIS DOCUMENT, EVEN IF ATMEL HAS BEEN ADVISED OF THE POSSIBILITY OF SUCH DAMAGES.** Atmel makes no representations or warranties with respect to the accuracy or completeness of the contents of this document and reserves the right to make changes to specifications and product descriptions at any time without notice. Atmel does not make any commitment to update the information contained herein. Unless specifically provided otherwise, Atmel products are not suitable for, and shall not be used in, automotive applications. Atmel's products are not intended, authorized, or warranted for use as components in applications intended to support or sustain life.

© 2009 Atmel Corporation. All rights reserved. Atmel®, Atmel logo and combinations thereof, AVR®, Adjacent Key Suppression® and others are registered trademarks, maXTouch™, AKS™, QMatrix™, XMEGA™ and others are trademarks of Atmel Corporation or its subsidiaries. Other terms and product names may be registered trademarks or trademarks of others.