

AND1021ST/-EO

120 x 64 Dots

Intelligent Graphics Display

The AND1021ST/-EO devices are compact, full dot matrix, LCD modules that have an on-board LCD controller (T6963C) and display memory (RAM). The AND1021ST/-EO can display TEXT information, numerals, letters and symbols, as well as GRAPHIC patterns. These devices are suitable for medical and measurement equipment, point-of-sale terminals, portable equipment, and marine instrumentation.

Features

- Super twist
- 15 characters x 8 line capability
- 120 x 64 dot graphic display
- Excellent readability and high-contrast ratio
- Built-in LCD controller (T6963C)
- Wide operating temperature range (0° to 50°C)
- Available with EL backlighting (-EO option)

• RoHS Compliant

Dot Matrix Dimensions

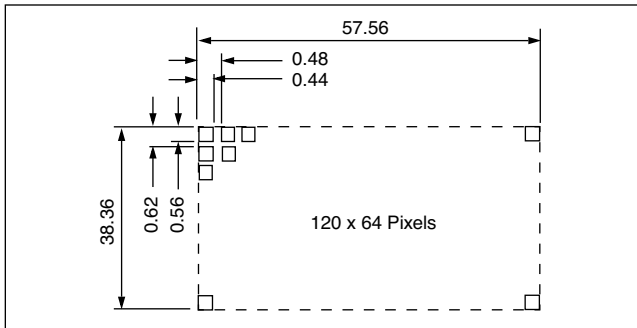

Mechanical Characteristics

Item	Specification	Unit
Outline Dimensions	85.0 (W) x 70.0 (H) x 20.0 MAX (D)	mm
Number of Dots	120 x 64 Dots (15)	
# of Characters	15 x 8 (120) Characters, 8 x 8 font	
Viewing Area	62.5 (W) x 43.5 (H)	mm
Bezel Opening	62.5 (W) x 43.5 (H)	mm
Dot Size	0.44 (W) x 0.56 (H)	mm
Dot Pitch	0.56 (W) x 0.60 (H)	mm
Weight (approx.)	70/85 (ST/EO)	gram

Absolute Maximum Ratings

Item	Symbol	Rating	Unit
Supply Voltage	V_{DD}	7.0	V
	V_{EE}	-22	
	V_{EL}	110 (EO)	V_{rms}
Input Voltage	V_{IN}	$GND \leq V_{IN} \leq V_{DD}$	V
Operating Temperature	T_{op}	0 to +50	°C
Storage Temperature	T_{stg}	-20 to +60	°C
EL Driving Freq. (EO)	f_{EL}	1	kHz

Electrical Characteristics (TA = 25°C)

Item	Symbol	Min.	Typ.	Max.	Unit
Supply Voltage	V_{DD}	4.75	5.0	5.25	V
	V_{EE}	-7.75	-8.5	-9.25	
EL Drive voltage ($f_{EL} = 500$ Hz)	V_{EL}	100	110	120	V_{rms}
High Level In Voltage ($V_{DD} = 5.0V$)	V_{IN}	-0.5	-	V_{DD}	V
Low Level In Voltage ($V_{DD} = 5.0V$)	V_{IH}	0	-	0.5	V
High Level Output Volt. ($V_{DD} = 5.0V$)	V_{OH}	$V_{DD} - 0.3$	-	-	V
Low Level Output Volt. ($V_{DD} = 5.0V$)	V_{OL}	-	-	0.3	V
Power Consumption ⁽¹⁾	I_{DD}	-	-	10.0	mA
	I_{EE}	-	-	2.0	
	I_{EL}	-	-	15	

1. All dots on. ($V_{DD} = .5V$, $V_{EE} = -8.5V$, $V_{EL} = 110$, $f_{EL} = 500$ Hz or at Typ.)

2. mA rms

Product specifications contained herein may be changed without prior notice.

It is therefore advisable to contact Purdy Electronics before proceeding with the design of equipment incorporating this product.





AND1021ST/-EO Intelligent Graphics Display

Optical Characteristics (TA = 25°C, φ = 0°, θ = 0)

Item	Symbol	Min.	Typ.	Max.	Unit
Viewing Angle	Right to Left	–	80	–	degree
	Up & Down	–	55	–	
Contrast	K	2.5	4.8	–	–
Turn On	T _{on}	–	200	350	ms
Turn Off	T _{off}	–	250	350	ms

Note: Refer to Applications Section for definitions of viewing angle, contrast ratio, response time (on and off) and luminance.

Connector Pin Assignment

Pin No.	Signal	Function
1	FGND	Frame Ground (connected to metal bezel)
2	GND	Ground (signal)
3	V _{DD}	Power Supply for logic (5V)
4	V _{EE}	Power Supply for LCD Drive
5	\overline{WR}	Data Write
6	\overline{RD}	Data Read
7	\overline{CE}	Chip Enable
8	C/ \overline{D}	\overline{WR} = "L", C/ \overline{D} = "H": Command Write \overline{WR} = "L", C/ \overline{D} = "L": Data Write \overline{RD} = "L", C/ \overline{D} = "H": Status Read \overline{RD} = "L", C/ \overline{D} = "L": Data Read
9	NC	No connection
10	\overline{RESET}	Controller Reset
11	D0	Data Input/Output
12	D1	Data Input/Output
13	D2	Data Input/Output
14	D3	Data Input/Output
15	D4	Data Input/Output
16	D5	Data Input/Output
17	D6	Data Input/Output
18	D7	Data Input/Output
19	NC	No connection
20	NC	No connection

Power Supply

The LCD panel is driven by the voltage V_{DD}-V_{EE}, so adjustable

V_{EE} is required for contrast control and temperature compensation.

Temperature Variations

Temperature	V _{DD} -V _{EE}	V _{DD} -V _{EE} (EO option)
0°C	14.6	14.1
+25°C	13.5	13.0
+50°C	11.6	11.1

Example of Variable Negative Voltage Supply

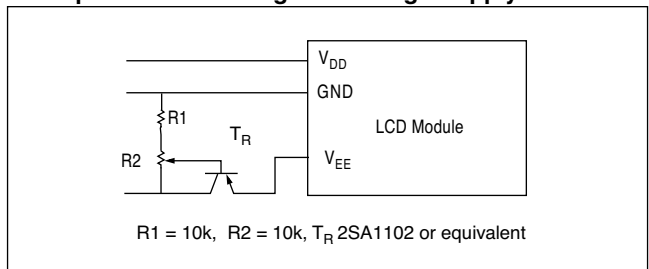

Timing Relationships and Diagram

Signal Timing Relationships

Item	Symbol	Min.	Max.	Unit
C/D Set Up Time	t _{CDS}	100	–	ns
C/D Hold Time	t _{CDH}	10	–	
\overline{CE} , \overline{RD} , \overline{WR} Pulse Width	t _{CE} , t _{RD} , t _{WR}	80	–	
Data Set Up Time	t _{DS}	80	–	
Data Hold Time	t _{DH}	40	–	
Access Time	t _{ACC}	–	150	
Output Hold Time	t _{OH}	10	50	

Timing Diagram

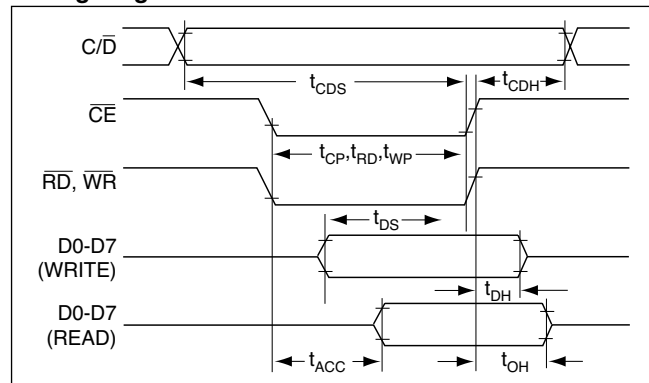



AND1021ST/-EO Intelligent Graphics Display

Block Diagram

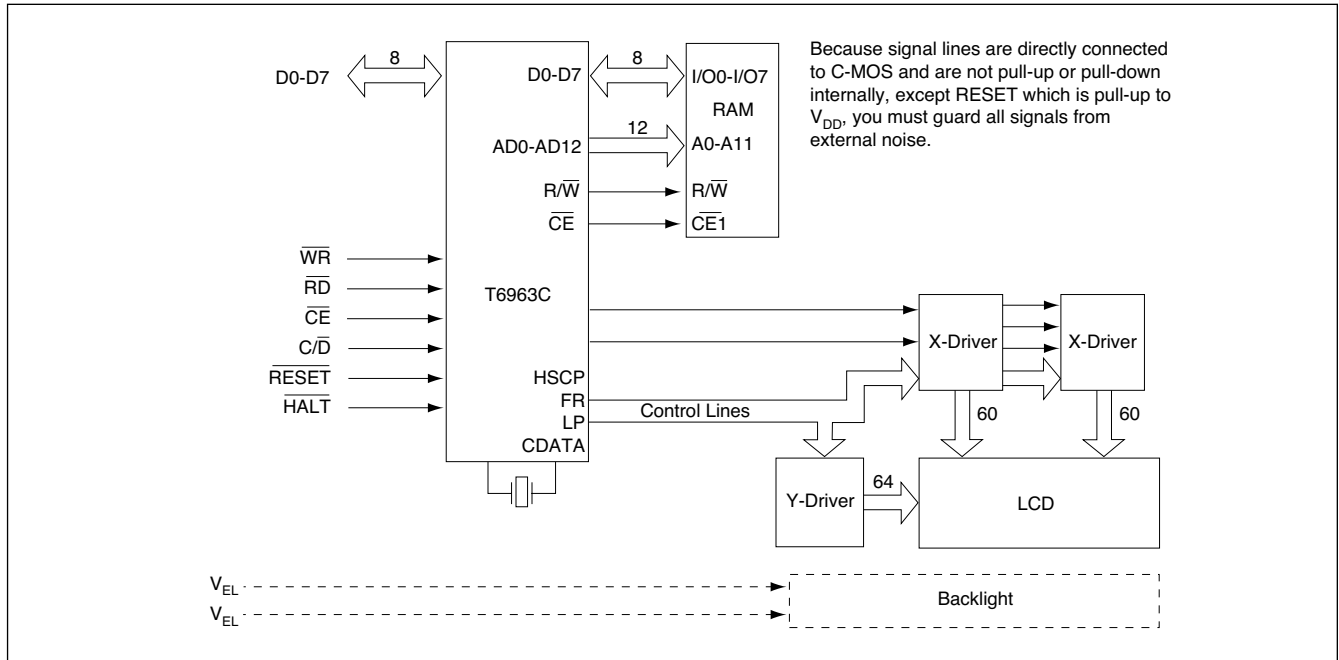

Dimensional Outline

