

PLEASE CHECK WWW.MOLEX.COM FOR LATEST PART INFORMATION

Part Number: [0009017171](#)
Status: **Active**
Overview: edge card connectors
Description: 3.96mm (.156") Pitch KK® Crimp Housing, Edge Card Connector, Single-Sided, Surface Mount, Polarized, With Flange, 17 Circuits, Rib between 5 & 6, 10 & 11, 14 & 15

Documents:

[3D Model](#) [Packaging Specification \(PDF\)](#)
[Drawing \(PDF\)](#) [RoHS Certificate of Compliance \(PDF\)](#)

Agency Certification

UL E29179

General

Product Family Edge Card Connectors
 Series [2574](#)
 Component Type Edgecard to Wire
 Overview [edge_card_connectors](#)
 Product Name Edge Card, KK®

Physical

Circuits (Loaded) 17
 Circuits (maximum) 17
 Circuits Detail All Signal
 Color - Resin Natural
 Durability (mating cycles max) 25
 Entry Angle Vertical (Top Entry)
 Flammability 94V-2
 Keying to Mating Part Yes
 Material - Plating Mating n/a
 Material - Resin Nylon
 PCB Retention None
 PCB Thickness Recommended (in) 0.062 In
 PCB Thickness Recommended (mm) 1.60 mm
 Packaging Type Bag
 Panel Mount With Flange
 Pitch - Mating Interface (in) 0.156 In
 Pitch - Mating Interface (mm) 3.96 mm
 Polarized to Mating Part Yes
 Temperature Range - Operating 0°C to +75°C
 Termination Interface: Style N/A

Electrical

Current - Maximum per Contact 4.25A, 4.5A, 4.75A, 4A, 5A
 Voltage - Maximum 250V

Material Info

Old Part Number 2574-17B10

Reference - Drawing Numbers

Packaging Specification PK-2574-001
 Sales Drawing SD-2574

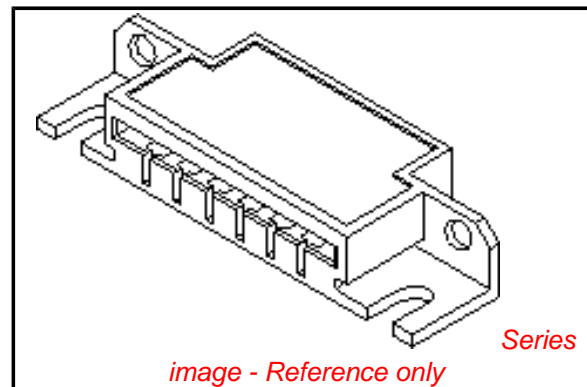

EU RoHS

ELV and RoHS Compliant
REACH SVHC Contains SVHC: No
Halogen-Free
Status Not Reviewed

China RoHS



Need more information on product environmental compliance?

Email productcompliance@molex.com
 For a multiple part number RoHS Certificate of Compliance, [click here](#)

Please visit the [Contact Us](#) section for any non-product compliance questions.

Search Parts in this Series

[2574Series](#)

Mates With

PCB, 1.6mm (0.62") max. thickness

Use With

[2878](#) Terminals, [2478](#) Terminals, [2578](#) Terminals, Bifurcated

PLEASE CHECK WWW.MOLEX.COM FOR LATEST PART INFORMATION

NOTES:

1. MATERIAL: NYLON 6/6, 94V-2.
2. FINISH: SEE CRIMP TERMINAL DRAWING.
3. THIS PRODUCT CONFORMS TO PRODUCT SPECIFICATION PS-08-50.
4. PACKAGING: BULK PER PK-2574-001
5. CONNECTOR TO BE USED WITH CRIMP TERMINALS:
 2478-* 18-24 GAGE WIRE; .110/(2.79) MAX. INSULATION DIAMETER.
 2578-* 22-26 GAGE WIRE; .065/(1.65) MAX. INSULATION DIAMETER.
6. DIMENSIONS GIVEN ACROSS CENTERLINES ARE SYMMETRICAL ABOUT THOSE CENTERLINES WITHIN ONE HALF THE TOTAL TOLERANCE.
7. PARTS LESS THAN 7 CIRCUITS ARE TO INDICATE ONLY CIRCUIT NO. 1. ALL OTHERS ARE TO IDENTIFY BOTH THE FIRST AND LAST CIRCUITS.
8. PART CONFORMS TO CLASS B REQUIREMENTS OF COSMETIC SPECIFICATION PS-45499-002

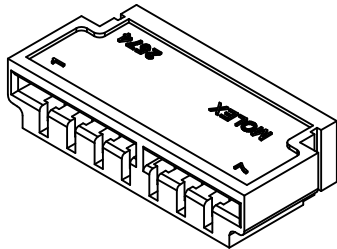
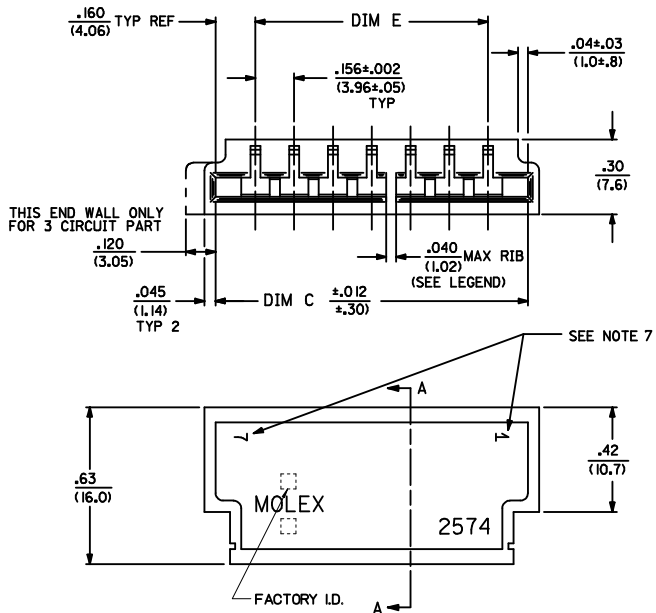

SECTION A-A

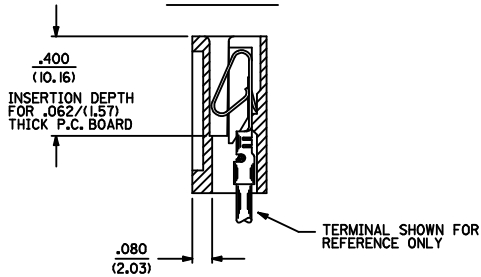

2574 - N * * *

NO. OF CIRCUITS
 COLOR CODE
 BLANK=NATURAL
 BK=BLACK

OPTION CODE

| CODE | MOUNTING EARS | CHAMFERED SLOT | PCB THK | MOUNTING HOLES |
|------|---------------|----------------|---------|----------------|
| A | NO | NO | .062 | NO |
| B | YES | NO | .062 | NO |
| C | NO | YES | .062 | NO |
| D | YES | YES | .062 | NO |
| E | NO | NO | .032 | NO |
| F | YES | NO | .062 | YES |

RIB LOCATION CODE (BETWEEN CKTS)

- 1 = NONE
- 2 = 2-3
- 3 = 3-4
- 4 = 5-6
- 5 = 3-4, 5-6
- 6 = 4-5, 7-8
- 7 = 5-6, 8-9
- 8 = 5-6, 10-11
- 9 = 4-5, 7-8, 11-12
- 10 = 5-6, 10-11, 14-15
- 11 = 5-6, 10-11, 15-16
- 12 = 5-6, 11-12, 16-17
- 13 = 5-6, 11-12, 17-18
- 14 = 4-5, 7-8, 11-12, 15-16
- 15 = 4-5, 8-9, 12-13, 16-17, 20-21
- 16 = 5-6, 11-12, 18-19

| | |
|----|------|
| 3 | C10 |
| 2 | C10 |
| 1 | C10 |
| SN | REV. |

| | | | | | | | | |
|--|------------------------------------|---|-------------------------------------|---------------------------------|---|---------------------|----------------------|------------------------|
| ADD PART NUMBERS DEC NO: UCP2009-0858 DRAWN/KIPER 2008/12/29 CHKD/SOUSEK 2008/12/30 APPR/FSMTH 2009/01/05 | QUALITY SYMBOLS =0 =0 | GENERAL TOLERANCES (UNLESS SPECIFIED) | | DIMENSION STYLE IN/MM | | SCALE 4:1 | DESIGN UNITS INCH | THIRD ANGLE PROJECTION |
| | | 4 PLACES ± --- ± --- 3 PLACES ± --- ± .010 2 PLACES ± 0.25 ± .015 1 PLACE ± 0.36 ± --- | DRAWN BY PEREZ-ARGUET 1988/03/02 | CHECKED BY PATEL 1988/03/02 | TITLE EDGE CARD CONNECTOR .156/(3.96) CENTERS CRIMP TYPE-2574 SERIES | | | |
| | | ANGULAR ±1/2° | APPROVED BY LENZ 1988/03/02 | MATERIAL NO. SEE CHART | | | MOLEX INCORPORATED | |
| | | DRAFT WHERE APPLICABLE MUST REMAIN WITHIN DIMENSIONS | SIZE D | | DOCUMENT NO. SD-2574 | SHEET NO. 1 OF 3 | | |

| NO. OF CKT'S | DIM. C | DIM. D | DIM. E | DIM. A |
|--------------|------------------|-------------------|---------------------------|------------------|
| 3 | .632 (16.05) | 1.143 (29.03) | .312±.002 (7.92±.05) | .618 (15.70) |
| 4 | .788 (20.02) | 1.224 (31.09) | .468±.002 (11.89±.05) | .774 (19.66) |
| 5 | .944 (23.98) | 1.380 (35.05) | .624±.003 (15.85±.08) | .922 (23.42) |
| 6 | 1.100 (27.94) | 1.536 (39.01) | .780±.003 (19.81±.08) | 1.078 (27.38) |
| 7 | 1.256 (31.90) | 1.692 (42.98) | .936±.003 (23.77±.08) | 1.232 (31.29) |
| 8 | 1.412 (35.86) | 1.848 (46.94) | 1.092±.004 (27.74±.10) | 1.388 (35.26) |
| 9 | 1.568 (39.83) | 2.004 (50.90) | 1.248±.004 (31.70±.10) | 1.544 (39.22) |
| 10 | 1.724 (43.79) | 2.160 (54.86) | 1.404±.006 (35.66±.15) | 1.700 (43.18) |
| 11 | 1.880 (47.75) | 2.316 (58.83) | 1.560±.006 (39.62±.15) | 1.854 (47.09) |
| 12 | 2.036 (51.71) | 2.472 (62.79) | 1.716±.006 (43.59±.15) | 2.010 (51.05) |
| 13 | 2.192 (55.68) | 2.628 (66.75) | 1.872±.006 (47.55±.15) | 2.164 (54.97) |
| 14 | 2.348 (59.64) | 2.784 (70.71) | 2.028±.007 (51.51±.18) | 2.318 (58.88) |
| 15 | 2.504 (63.60) | 2.940 (74.68) | 2.184±.007 (55.47±.18) | 2.474 (62.84) |
| 16 | 2.660 (67.56) | 3.096 (78.64) | 2.340±.007 (59.44±.18) | 2.631 (66.83) |
| 17 | 2.816 (71.53) | 3.252 (82.60) | 2.496±.008 (63.40±.20) | 2.784 (70.71) |
| 18 | 2.972 (75.49) | 3.408 (86.56) | 2.652±.009 (67.36±.23) | 2.954 (75.03) |
| 19 | 3.128 (79.45) | 3.564 (90.53) | 2.808±.009 (71.32±.23) | 3.095 (78.61) |
| 20 | 3.284 (83.41) | 3.720 (94.49) | 2.964±.009 (75.29±.23) | 3.251 (82.58) |
| 21 | 3.440 (87.38) | 3.876 (98.45) | 3.120±.010 (79.25±.25) | 3.407 (86.54) |
| 22 | 3.596 (91.34) | 4.032 (102.41) | 3.276±.011 (83.21±.25) | 3.562 (90.47) |
| 23 | 3.752 (95.30) | 4.188 (106.38) | 3.432±.011 (87.17±.28) | 3.716 (94.39) |
| 24 | 3.908 (99.26) | 4.344 (110.34) | 3.588±.012 (91.14±.30) | 3.871 (98.32) |

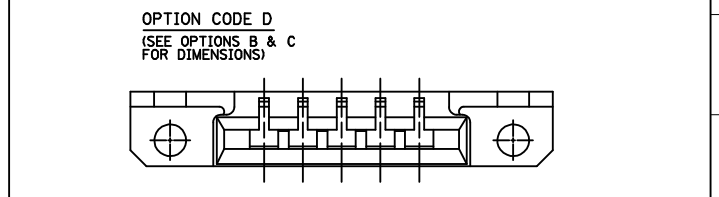
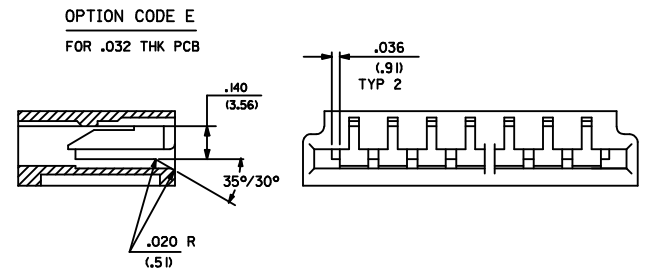
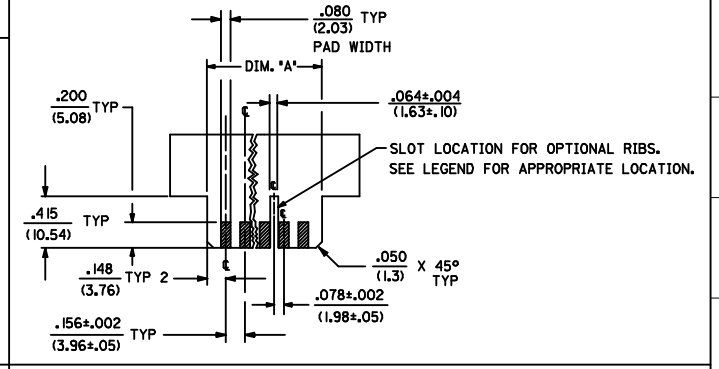
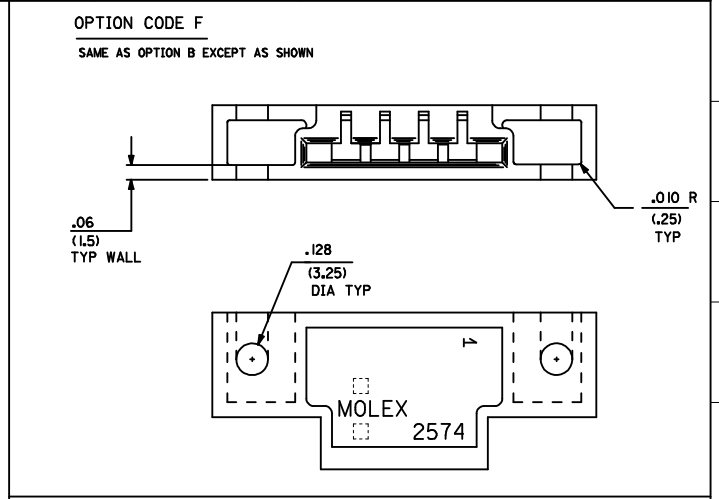
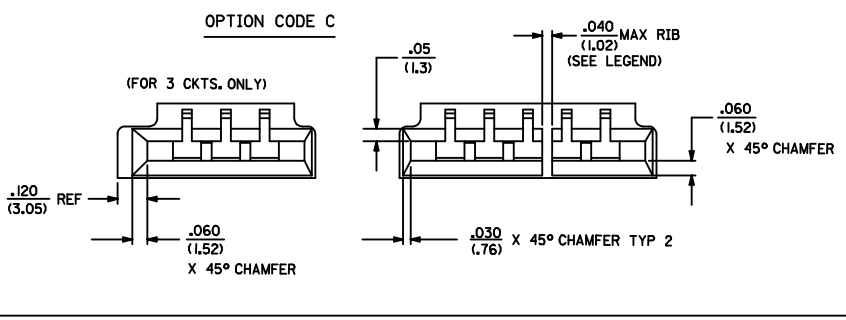
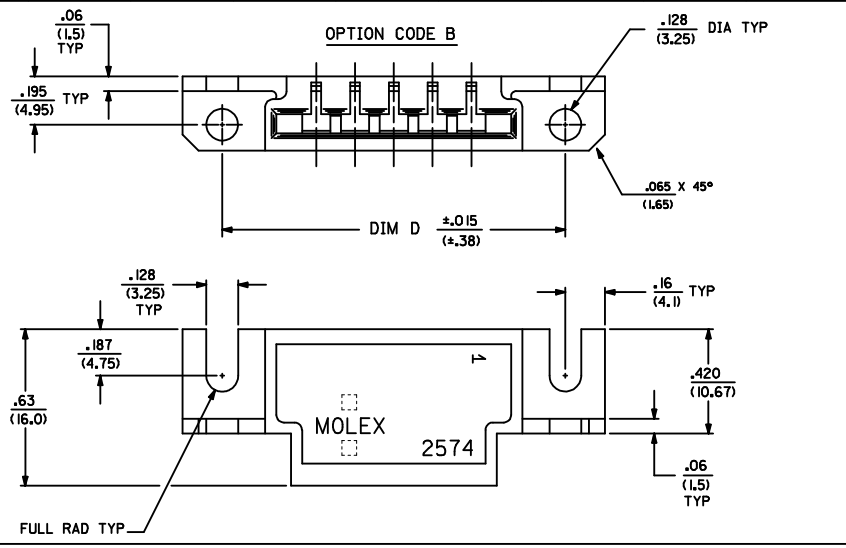

| | | | | | | | |
|---|--------------------------------------|---|------------|--|---|----------------------------------|------------------------|
| REVISE FACTORY ID. REC NO. UCF2009-0858 DRAWN BY PEREZ-ARGUET CHKD BY PATEL APPR:FSM TH 2009/01/05 | QUALITY SYMBOLS ▽=0 ▽=0 | GENERAL TOLERANCES (UNLESS SPECIFIED) | | DIMENSION STYLE IN/MM | SCALE --- | DESIGN UNITS INCH | THIRD ANGLE PROJECTION |
| | | 4 PLACES ± --- ± --- 3 PLACES ± --- ± .005 2 PLACES ± 0.13 ± .01 1 PLACE ± 0.25 ± --- | mm INCH | DRAWN BY PEREZ-ARGUET CHECKED BY PATEL APPROVED BY ENZ | DATE 1988/03/02 DATE 1988/03/02 DATE 1988/03/02 | MATERIAL NO. SEE CHART SIZE D | DOCUMENT NO. SD-2574 |
| DRAFT WHERE APPLICABLE MUST REMAIN WITHIN DIMENSIONS | | THIS DRAWING CONTAINS INFORMATION THAT IS PROPRIETARY TO MOLEX INCORPORATED AND SHOULD NOT BE USED WITHOUT WRITTEN PERMISSION | | | | | |

| | 2574-NA* | | 2574-NB* | | 2574-NC* | | 2574-ND* | | 2574-NE* | | 2574-NF* | |
|---|------------|------------------------|------------|------------------------|-------------|------------------------|------------|------------------------|----------|------------------------|------------|------------------------|
| | PART NO. | ENG. NO. (SUFFIX ONLY) | PART NO. | ENG. NO. (SUFFIX ONLY) | PART NO. | ENG. NO. (SUFFIX ONLY) | PART NO. | ENG. NO. (SUFFIX ONLY) | PART NO. | ENG. NO. (SUFFIX ONLY) | PART NO. | ENG. NO. (SUFFIX ONLY) |
| M | 09-01-6031 | -3A1 | 09-01-7031 | -3B1 | 09-01-6038 | -3C1 | 09-01-6082 | -3D | | -4E1 | 09-01-7065 | -6F1-BK |
| | 09-01-6041 | -4A1 | 09-01-7041 | -4B1 | 009-01-6048 | -04C1 | | | | -6E1 | 09-01-7087 | -8F1-BK |
| | 09-01-6051 | -5A1 | 09-01-7051 | -5B1 | 09-01-6088 | -08C1 | | | | | | |
| | 09-01-6064 | -6A1 | 09-01-7064 | -6B1 | | -20C1 | | | | | | |
| | 09-01-6081 | -8A1 | 09-01-7081 | -8B1 | | | | | | | | |
| L | | -8A1D | 09-01-7069 | -6B1D | | | | | | | | |
| | 09-01-6055 | -5A2 | | -8B1D | | | | | | | | |
| | 09-01-6061 | -6A2 | 09-01-7061 | -6B2 | | | | | | | | |
| | 09-01-6085 | -8A2 | 09-01-7085 | -8B2 | | | | | | | | |
| | 09-01-6095 | -9A2 | 09-01-7095 | -9B2 | | | | | | | | |
| | 09-01-6071 | -7A3 | 09-01-7071 | -7B3 | | | | | | | | |
| | 09-01-6086 | -8A3 | 09-01-7086 | -8B3 | | | | | | | | |
| K | 09-01-6083 | -8A4 | 09-01-7083 | -8B4 | | | | | | | | |
| | 09-01-6094 | -9A4 | 09-01-7094 | -9B4 | | | | | | | | |
| | 09-01-6091 | -9A5 | 09-01-7091 | -9B5 | | | | | | | | |
| | 09-01-6101 | -10A6 | 09-01-7101 | -10B6 | | | | | | | | |
| | 09-01-6121 | -12A7 | 09-01-7121 | -12B7 | | | | | | | | |
| | 09-01-6129 | -12A4 | 09-01-7129 | -12B4 | | | | | | | | |
| J | 09-01-6181 | -18A8 | 09-01-7181 | -18B8 | | | | | | | | |
| | 09-01-6151 | -15A9 | 09-01-7151 | -15B9 | | | | | | | | |
| | 09-01-6161 | -16A9 | 09-01-7161 | -16B9 | | | | | | | | |
| | 09-01-6171 | -17A10 | 09-01-7171 | -17B10 | | | | | | | | |
| | 09-01-6211 | -21A11 | 09-01-7211 | -21B11 | | | | | | | | |
| | 09-01-6224 | -22A12 | 09-01-7224 | -22B12 | | | | | | | | |
| | 09-01-6221 | -22A13 | 09-01-7221 | -22B13 | | | | | | | | |
| I | 09-01-6191 | -19A14 | 09-01-7191 | -19B14 | | | | | | | | |
| | 09-01-6241 | -24A15 | 09-01-7241 | -24B15 | | | | | | | | |
| | 09-01-7222 | -22A16 | | -6B1-BK | | | | | | | | |

| | | | | | | | | |
|--|------------------------------------|---|---|---|---|-----------------------------|--|------------------|
| ADD PART NUMBERS DEC. NO. UCP2009-0858 DRAWN BY PER 2008/12/29 CHKD:SSOUSEK 2008/12/30 APPR:FSM TH 2009/01/05 | QUALITY SYMBOLS =0 =0 | GENERAL TOLERANCES (UNLESS SPECIFIED) | | DIMENSION STYLE IN/MM | SCALE --- | DESIGN UNITS INCH | THIRD ANGLE PROJECTION | |
| | | 4 PLACES # --- # --- 3 PLACES # --- # --- 2 PLACES # --- # --- 1 PLACE # --- # --- | mm INCH # --- # --- # --- # --- # --- # --- # --- # --- | DRAWN BY PEREZ-ARGUET 1988/03/02 CHECKED BY DATE PATEL 1988/03/02 APPROVED BY DATE ENZ 1988/03/02 | TITLE EDGE CARD CONNECTOR .156/(3.96) CENTERS CRIMP TYPE-2574 SERIES | MOLEX INCORPORATED | MATERIAL NO. SD-2574 DOCUMENT NO. SD-2574 | SHEET NO. 3 OF 3 |
| | | DRAFT WHERE APPLICABLE MUST REMAIN WITHIN DIMENSIONS | | SEE CHART | THIS DRAWING CONTAINS INFORMATION THAT IS PROPRIETARY TO MOLEX INCORPORATED AND SHOULD NOT BE USED WITHOUT WRITTEN PERMISSION | | | |
| | | SIZE D | | | | | | |