



# HDMI Receiver Port Protection and Interface Device

## CM2030

### Features

- HDMI 1.3 compliant
- Supports thin dielectric and 2-layer boards
- Minimizes TMDS skew with 0.05pF matching
- Long HDMI cable support with integrated I<sup>2</sup>C accelerator
- Active termination and slew rate limiting for CEC
- Supports direct connection to CEC microcontroller
- Integrated I<sup>2</sup>C level shifting to CMOS level including low logic level voltages
- Integrated 8kV ESD protection and backdrive protection on all external I/O lines
- Integrated overcurrent output protection per HDMI 1.3
- Multiport I<sup>2</sup>C support eliminates need for analog mux on DDC lines
- Simplified layout with matched 0.5mm trace spacing
- RoHS-compliant, lead-free packaging

### Applications

- PC and consumer electronics
- Set top box, DVD RW, PC, graphics cards

### Product Description

The CM2030 HDMI Transmitter Port Protection and Interface Device is specifically designed for next generation HDMI Host interface protection.

An integrated package provides all ESD, slew rate limiting on CEC line, level shifting/isolation, overcurrent output protection and backdrive protection for an HDMI port in a single 38-pin TSSOP package.

The CM2030 part is specifically designed to provide the designer with the most reliable path to HDMI 1.3 CTS compliance.

The CM2030 also incorporates a silicon overcurrent protection device for +5V supply voltage output to the connector.

Electrical Schematic

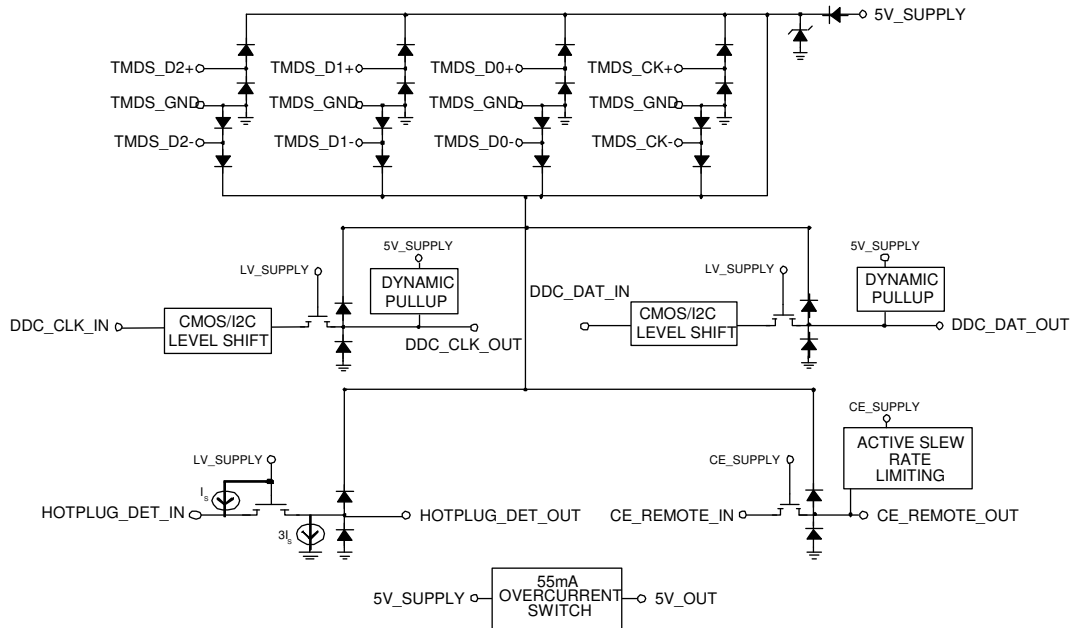

PACKAGE / PINOUT DIAGRAM

TOP VIEW

5V_SUPPLY	1	38	5V_OUT
LV_SUPPLY	2	37	CE_SUPPLY
GND	3	36	GND
TMDS_D2+	4	35	TMDS_D2+
TMDS_GND	5	34	TMDS_GND
TMDS_D2-	6	33	TMDS_D2-
TMDS_D1+	7	32	TMDS_D1+
TMDS_GND	8	31	TMDS_GND
TMDS_D1-	9	30	TMDS_D1-
TMDS_D0+	10	29	TMDS_D0+
TMDS_GND	11	28	TMDS_GND
TMDS_D0-	12	27	TMDS_D0-
TMDS_CK+	13	26	TMDS_CK+
TMDS_GND	14	25	TMDS_GND
TMDS_CK-	15	24	TMDS_CK-
CE_REMOTE_IN	16	23	CE_REMOTE_OUT
DDC_CLK_IN	17	22	DDC_CLK_OUT
DDC_DAT_IN	18	21	DDC_DAT_OUT
HOTPLUG_DET_IN	19	20	HOTPLUG_DET_OUT

Note: This drawing is not to scale.

38-PIN TSSOP PACKAGE

## PIN DESCRIPTIONS

		ESD Level	DESCRIPTION
4, 35	TMDS_D2+	8kV <sup>3</sup>	TMDS 0.9pF ESD protection. <sup>1</sup>
6, 33	TMDS_D2-	8kV <sup>3</sup>	TMDS 0.9pF ESD protection. <sup>1</sup>
7, 32	TMDS_D1+	8kV <sup>3</sup>	TMDS 0.9pF ESD protection. <sup>1</sup>
9, 30	TMDS_D1-	8kV <sup>3</sup>	TMDS 0.9pF ESD protection. <sup>1</sup>
10, 29	TMDS_D0+	8kV <sup>3</sup>	TMDS 0.9pF ESD protection. <sup>1</sup>
12, 27	TMDS_D0-	8kV <sup>3</sup>	TMDS 0.9pF ESD protection. <sup>1</sup>
13, 26	TMDS_CK+	8kV <sup>3</sup>	TMDS 0.9pF ESD protection. <sup>1</sup>
15, 24	TMDS_CK-	8kV <sup>3</sup>	TMDS 0.9pF ESD protection. <sup>1</sup>
16	CE_REMOTE_IN	2kV <sup>4</sup>	CE_SUPPLY referenced logic level in.
23	CE_REMOTE_OUT	8kV <sup>3</sup>	5V_SUPPLY referenced logic level out plus 10pF ESD. <sup>6</sup>
17	DDC_CLK_IN	2kV <sup>4</sup>	LV_SUPPLY referenced logic level in.
22	DDC_CLK_OUT	8kV <sup>3</sup>	5V_SUPPLY referenced logic level out plus 10pF ESD. <sup>6</sup>
18	DDC_DAT_IN	2kV <sup>4</sup>	LV_SUPPLY referenced logic level in.
21	DDC_DAT_OUT	8kV <sup>3</sup>	5V_SUPPLY referenced logic level out plus 10pF ESD. <sup>6</sup>
19	HOTPLUG_DET_IN	2kV <sup>4</sup>	LV_SUPPLY referenced logic level in.
20	HOTPLUG_DET_OUT	8kV <sup>3</sup>	5V_SUPPLY referenced logic level out plus 10pF ESD. A 0.1μF bypass ceramic capacitor is recommended on this pin. <sup>2</sup>
2	LV_SUPPLY	2kV <sup>4</sup>	Bias for CE / DDC / HOTPLUG level shifters.
37	CE_SUPPLY	2kV <sup>4,2</sup>	CEC bias voltage. Previously CM2020 ESD_BYN pin.
1	5V_SUPPLY	2kV <sup>4</sup>	Current source for 5V_OUT, VREF for DDC I <sup>2</sup> C voltage references, and bias for 8kV ESD pins.
38	5V_OUT	8kV <sup>3</sup>	55mA minimum overcurrent protected 5V output. This output must be bypassed with a 0.1μF ceramic capacitor.
3, 5, 8, 11, 14, 25, 28, 31, 34, 36	GND / TMDS_GND	N/A	GND reference.

Note 1: These 2 pins need to be connected together in-line on the PCB. See recommended layout diagram.

Note 2: This output can be connected to an external 0.1μF ceramic capacitor/pads to maintain backward compatibility with the CM2020.

Note 3: Standard IEC 61000-4-2, C<sub>DISCHARGE</sub>=150pF, R<sub>DISCHARGE</sub>=330Ω, 5V\_SUPPLY and LV\_SUPPLY within recommended operating conditions, GND=0V, 5V\_OUT (pin 38), and HOTPLUG\_DET\_OUT (pin 20) each bypassed with a 0.1μF ceramic capacitor connected to GND.

Note 4: Human Body Model per MIL-STD-883, Method 3015, C<sub>DISCHARGE</sub>=100pF, R<sub>DISCHARGE</sub>=1.5kΩ, 5V\_SUPPLY and LV\_SUPPLY within recommended operating conditions, GND=0V, 5V\_OUT (pin 38), and HOTPLUG\_DET\_OUT (pin 20) each bypassed with a 0.1μF ceramic capacitor connected to GND.

Note 5: These pins should be routed directly to the associated GND pins on the HDMI connector with single point ground vias at the connector.

Note 6: The slew-rate control and active acceleration circuitry dynamically offsets the system capacitive load on these pins.

## Backdrive Protection and Isolation

Backdrive current is defined as the undesirable current flow through an I/O pin when that I/O pin's voltage exceeds the related local supply voltage for that circuitry. This is a potentially common occurrence in multimedia entertainment systems with multiple components and several power plane domains in each system.

For example, if a DVD player is switched off and an HDMI connected TV is powered on, there is a possibility of reverse current flow back into the main power supply rail of the DVD player from pull-ups in the TV. As little as a few milliamps of backdrive current flowing back into the power rail can charge the DVD player's bulk bypass capacitance on the power rail to some intermediate level. If this level rises above the power-on-reset (POR) voltage level of some of the integrated circuits in the DVD player, then these devices may not reset properly when the DVD player is turned back on.

If any SOC devices are incorporated in the design which have built-in level shifter and/or ESD protection structures, there can be a risk of permanent damage due to backdrive. In this case, backdrive current can forward bias the on-chip ESD protection structure. If the current flow is high enough, even as little as a few milliamps, it could destroy one of the SOC chip's internal DRC diodes, as they are not designed for passing DC.

To avoid either of these situations, the CM2030 was designed to block backdrive current, guaranteeing less than 5 $\mu$ A into any I/O pin when the I/O pin voltage exceeds its related operating CM2030 supply voltage.

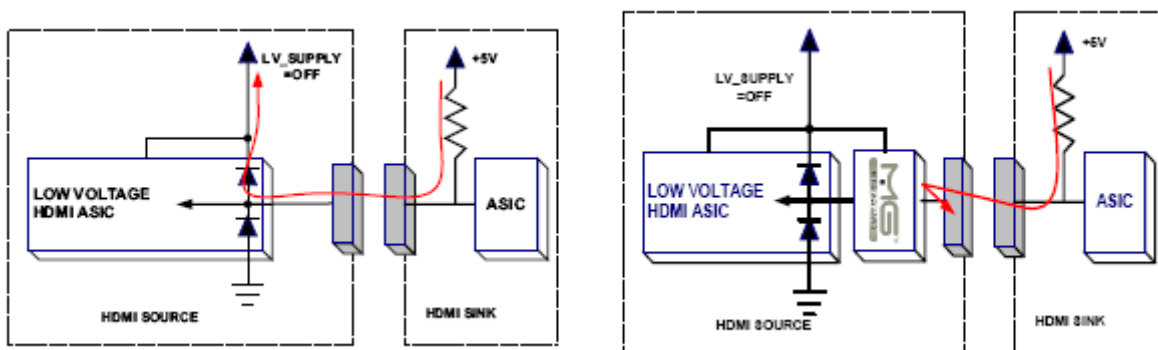

Figure 1. Backdrive Protection Diagram.

## Display Data Channel (DDC) lines

The DDC interface is based on the I<sup>2</sup>C serial bus protocol for EDID configuration.

### DYNAMIC PULLUPS

Based on the HDMI specification, the maximum capacitance of the DDC line can approach 800pF (50pF from source, 50pF from sink, and 700pF from cable). At the upper range of capacitance values (i.e. long cables), it becomes impossible for the DDC lines to meet the I<sup>2</sup>C timing specifications with the minimum pull-up resistor of 1.5k $\Omega$ .

For this reason, the CM2030 was designed with an internal I<sup>2</sup>C accelerator to meet the AC timing specification even with very long and non-compliant cables.

## CM2030

The internal accelerator increases the positive slew rate of the DDC\_CLK\_OUT and DDC\_DAT\_OUT lines whenever the sensed voltage level exceeds  $0.3 \cdot 5V\_SUPPLY$  (approximately 1.5V). This provides faster overall risetime in heavily loaded situations without overloading the multi-drop open drain I<sup>2</sup>C outputs elsewhere.

### DYNAMIC PULLUPS (CONT'D)

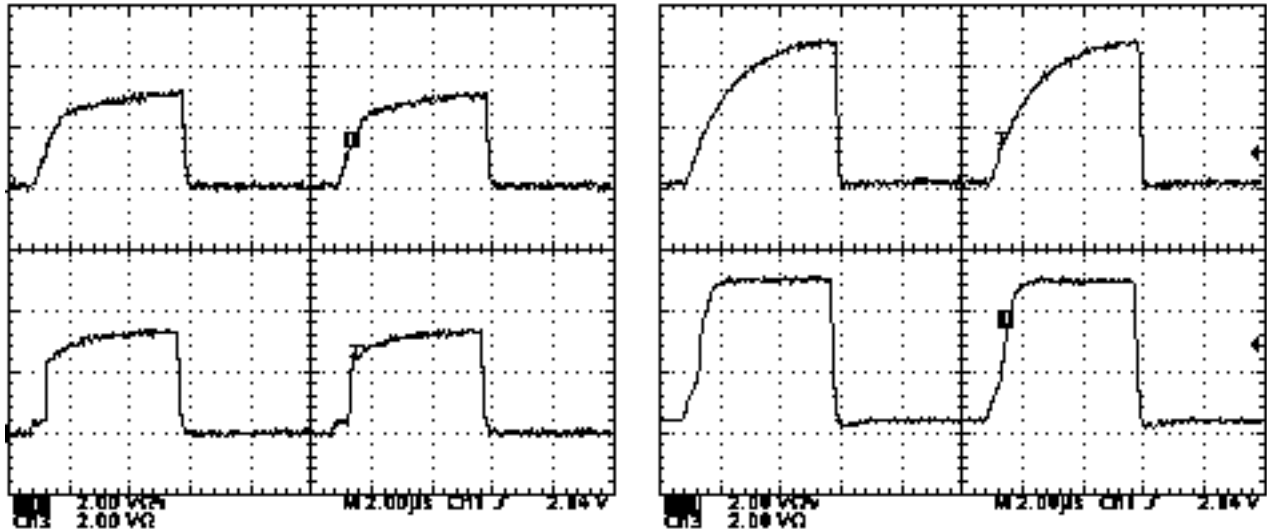

**Figure 2. Dynamic DDC Pullups** (Discrete - Top, CM2030 - Bottom; 3.3V ASIC - Left, 5V Cable - Right.)

Figure 2 demonstrates the “worst case” operation of the dynamic CM2030 DDC level shifting circuitry (bottom) against a discrete NFET common-gate level shifter circuit with a typical 1.5k $\Omega$  pullup at the source (top.) Both are shown driving an off-spec, but unfortunately readily available 31m HDMI cable which exceeds the 700pF HDMI specification. Some widely available HDMI cables have been measured at *over 4nF*.

When the standard I/OD cell releases the NFET discrete shifter, the risetime is limited by the pullup and the parasitics of the cable, source and sink. For long cables, this can extend the risetime and reduce the margin for reading a valid “high” level on the data line. In this case, an HDMI source may not be able to read uncorrupted data and will not be able to initiate a link.

With the CM2030’s dynamic pullups, when the ASIC driver releases its DDC line and the “OUT” line reaches at least  $0.3 \cdot VDD$  (of  $5V\_SUPPLY$ ), then the “OUT” active pullups are enabled and the CM2030 takes over driving the cable until the “OUT” voltage approaches the  $5V\_SUPPLY$  rail.

The internal pass element and the dynamic pullups also work together to damp reflections on the longer cables and keep them from glitching the local ASIC.

### I<sup>2</sup>C LOW LEVEL SHIFTING

In addition to the Dynamic Pullups described in the previous section, the CM2030 also incorporates improved I<sup>2</sup>C low-level shifting on the DDC\_CLK\_IN and DDC\_DAT\_IN lines for enhanced compatibility.

Typical discrete NFET level shifters can advertise specifications for low  $R_{DS(on)}$ , but usually state relatively high  $V_{GS}$  test parameters, requiring a 'switch' signal (gate voltage) as high as 10V or more. At a sink current of 4mA for the ASIC on DDC\_XX\_IN, the CM2030 guarantees no more than 140mV increase to DDC\_XX\_OUT, even with a switching control of 2.5V on LV\_SUPPLY.

When I<sup>2</sup>C devices are driving the external cable, an internal pulldown on DDC\_XX\_IN guarantees that the VOL seen by the ASIC on DDC\_XX\_IN is equal to or lower than DDC\_XX\_OUT.

**Multipoint DDC Multiplexing**

By switching LV\_SUPPLY, the DDC/HPD blocks can be independently disabled by engaging their inherent “backdrive” protection. This allows N:1 multiplexing of the low-speed HDMI signals without any additional FET switches.

**Consumer Electronics Control (CEC)**

The Consumer Electronics Control (CEC) line is a high level command and control protocol, based on a single wire multidrop open drain communication bus running at approximately 1kHz (See Figure 3). While the HDMI link provides only a single point-to-point connection, up to ten (10) CEC devices may reside on the bus, and they may be daisy chained out through other physical connectors including other HDMI ports or other dedicated CEC links. The high level protocol of CEC can be implemented in a simple microcontroller or other interface with any I/OD (input/open-drain) GPIO.

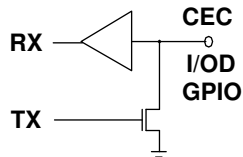

**Figure 3. Typical μC I/OD Driver**

To limit possible EMI and ringing in this potentially complex connection topology, the rise- and fall-time of this line are limited by the specification. However, meeting the slew-rate limiting requirements with additional discrete circuitry in this bi-directional block is not trivial without an additional RX/TX control line to limit the output slew-rate without affecting the input sensing (See Figure 4).

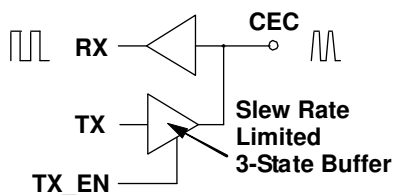
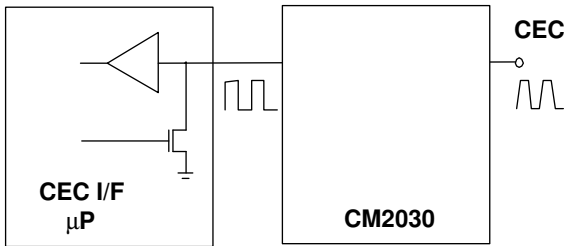

**Figure 4. Three-Pin External Buffer Control**

Simple CMOS buffers cannot be used in this application since the load can vary so much (total pullup of 27kΩ to less than 2kΩ, and up to 7.3nF total capacitance.) The CM2030 targets an output drive slew-rate of less than 100mV/ms regardless of static load for the CEC line. Additionally, the same internal circuitry will perform active termination, thus reducing ringing and overshoot in entertainment systems connected to legacy or poorly designed CEC nodes.

# CM2030

The CM2030's bi-directional slew rate limiting is integrated into the CEC level-shifter functionality thus allowing the designer to directly interface a simple low voltage CMOS GPIO directly to the CEC bus and simultaneously guarantee meeting all CEC output logic levels and HDMI slew-rate and isolation specifications (See Figure 5).



**Figure 5. Integrated CM2030 Solution**

The CM2030 also includes an internal backdrive protected static pullup 120 $\mu$ A current source from the CE\_SUPPLY rail in addition to the dynamic slew rate control circuitry.

Figure 6 shows a typical shaped CM2030 CEC output (bottom) against a ringing uncontrolled discrete solution (top).

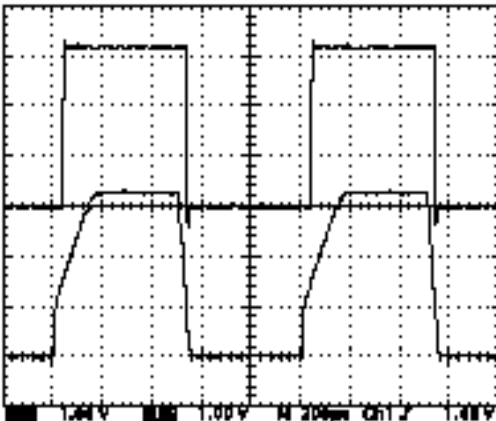
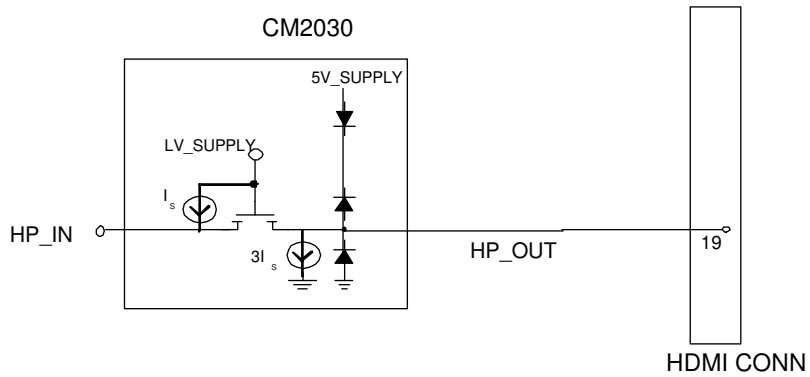

**Figure 6. CM2030 CEC Output**

## Hotplug Detect Logic

The CM2030 ensures that the local ASIC will properly detect an HDMI compliant Sink. The current sink maintains a local logic “low” when no system is connected.

A valid pullup on the HDMI connector pin will overdrive the internal pulldown and deliver a logic “high” to the local ASIC.



**Figure 7. Hotplug Detect Circuit**



# CM2030

## Ordering Information

PART NUMBERING INFORMATION			
38	TSSOP-38	CM2030-A0TR	CM2030-A0TR

Note 1: Parts are shipped in Tape & Reel form unless otherwise specified.

## Specifications

ABSOLUTE MAXIMUM RATINGS		
PARAMETER		
VCC5, VCCLV	6.0	V
DC Voltage at any Channel Input	[GND - 0.5] to [VCC + 0.5]	V
Storage Temperature Range	65 to +150	°C

STANDARD (RECOMMENDED) OPERATING CONDITIONS					
SYMBOL	PARAMETER				
5V_SUPPLY	Operating Supply Voltage		5	5.5	V
LV_SUPPLY	Bias Supply Voltage	1	3.3	5.5	V
CE_SUPPLY	Bias Supply Voltage	3	3.3	3.6	V
	Operating Temperature Range	40		85	°C

**ELECTRICAL OPERATING CHARACTERISTICS (SEE NOTE 1)**

SYMBOL	PARAMETER	CONDITIONS	MIN	TYP	MAX	UNITS
ICC5	Operating Supply Current	5V_SUPPLY = 5.0V, CEC_OUT = 3.3V, LV_SUPPLY= 3.3V,CE_SUPPLY= 3.3V, DDC=5V; Note6		300	350	μA
ICCLV	Bias Supply Current	LV_SUPPLY=3.3V; Note 6		60	150	μA
ICCCE	Bias Supply Current	CE_SUPPLY=3.3V, CEC_OUT=0V; Notes 6 and 7		60	150	μA
ICEC	Current source on CEC pin	CE_SUPPLY=3.3V,	111	120	128	μA
VDROP	5V_OUT Overcurrent Out put Drop	5V_SUPPLY=5.0V, IOOUT=55mA		65	100	mV
ISC	5V_OUT Short Circuit Current Limit	5V_SUPPLY=5.0V, 5V_OUT=GND	90	135	175	mA
IOFF	OFF state leakage current, level shifting NFET	LV_SUPPLY=0V		0.1	5	μA
IBACKDRIVECEC	Current through CE-REMOTE_OUT when powered down	CE-REMOTE_IN = CE_SUPPLY < CE_REMOTE_OUT		0.1	1.8	μA
IBACKDRIVETMDS	Current through TMDS pins when powered down	All Supplies = 0V; TMDS_[2:0]+/, TMDS_CK+/- = 4V		0.1	5	μA
IBACKDRIVE5V_OUT	Current through 5V_OUT when powered down	All Supplies = 0V; 5V_OUT_PIN = 5V		0.1	5	μA
IBACKDRIVEDDC	Current through DDC_DAT/CLK_OUT when powered down	All Supplies = 0V; DDC_DAT/CLK_OUT = 5V; DDC_DAT/CLK_IN = 0V		0.1	5	μA
IBACKDRIVEHOTPLUG	Current through HOTPLUG_DET_OUT when powered down	All Supplies = 0V; HOTPLUG_DET_OUT = 5V; HOTPLUG_IN = 0V		0.1	5	μA
CECSL	CEC Slew Limit	Measured from 10-90% or 90-10%		0.26	0.65	V/μs
CECRT	CEC Rise Time	Measured from 10-90% Assumes a signal swing from 0-3.3V	26.4		250	μs
CECFT	CEC Fall Time	Measured from 90-10% Assumes a signal swing from 0-3.3V	4		50	μs
VACC	Turn On Threshold of I2C/DDC Accelerator	Voltage is 0.3 ±10% X 5V_Supply; Note 2	1.35	1.5	1.65	V
VON(DDC_OUT)	Voltage drop across DDC level shifter	LV_SUPPLY=3.3V, 3mA Sink at DDCIN, DDCOUT < VACC		150	225	mV
VOL(DDC_IN)	Logic Level (ASIC side) when I2C/DDC Logic Low Applied; (I2C pass-through compatibility)	DDC_OUT=0.4V, LV_SUPPLY=3.3V, 1.5kΩ pullup on DDC_OUT to 5.0V; Note 2		0.3	0.4	V
tr(DDC)	DDC_OUT Line Risetime, VACC < VDDC_OUT <	DDC_IN floating, LV_SUPPLY=3.3V, 1.5kΩ pullup on			1	μs

# CM2030

	(5V_Supply-0.5V)	DDC_OUT to 5.0V, Bus Capacitance = 1500pF				
VF	Diode Forward Voltage Top Diode Bottom Diode	IF = 8mA, TA = 25 °C	0.6 0.6	0.85 0.85	0.95 0.95	V V
VESD	ESD Withstand Voltage (IEC)	Pins 4, 7, 10, 13, 20, 21, 22, 23, 24, 27, 30, 33, TA = 25 °C; Note 2	±8			kV
VESD	ESD Withstand Voltage (HBM)	Pins 1, 2, 16, 17, 18, 19, 37, 38, TA = 25 °C	±2			kV
VCL	Channel Clamp Voltage Positive Transients Negative Transients	TA=25 °C, IPP = 1A, tP = 8/20µS; Note 5		11.0 2.0		V V
RDYN	Dynamic Resistance Positive Transients Negative Transients	TA=25 °C, IPP = 1A, tP = 8/20µS Any I/O pin to Ground; Note5		1.4 0.9		Ω Ω
ILEAK	TMDS Channel Leakage Current	TA = 25 °C		0.01	1	µA
CIN, TMDS	TMDS Channel Input Capacitance	5V_SUPPLY=5.0V, Measured at 1MHz, VBIAS=2.5V		0.9	1.2	pF
ΔCIN, TMDS	TMDS Channel Input Capacitance Matching	5V_SUPPLY=5.0V, Measured at 1MHz, VBIAS=2.5V; Note 4		0.05		pF
CMUTUAL	Mutual Capacitance between signal pin and adjacent signal pin	5V_SUPPLY=0V, Measured at 1MHz, VBIAS=2.5V		0.07		pF
CIN, DDCOUT	Level Shifting Input Capacitance, Capacitance to GND	5V_SUPPLY=0V, Measured at 100KHz, VBIAS=2.5V		10		pF
CIN, CECOUT	Level Shifting Input Capacitance, Capacitance to GND	5V_SUPPLY=0V, Measured at 100KHz, VBIAS=1.65V		10		pF
CIN, HPOUT	Level Shifting Input Capacitance, Capacitance to GND	5V_SUPPLY=0V, Measured at 100KHz, VBIAS=2.5V		10		pF

Note 1: Operating Characteristics are over Standard Operating Conditions unless otherwise specified.

Note 2: Standard IEC61000-4-2, C<sub>DISCHARGE</sub>=150pF, R<sub>DISCHARGE</sub>=330Ω, 5V\_SUPPLY=5V, 3.3V\_SUPPLY=3.3V, LV\_SUPPLY=3.3V, GND=0V.

Note 3: Human Body Model per MIL-STD-883, Method 3015, C<sub>DISCHARGE</sub>=100pF, R<sub>DISCHARGE</sub>=1.5kΩ, 5V\_SUPPLY=5V, 3.3V\_SUPPLY=3.3V, LV\_SUPPLY=3.3V, GND=0V.

Note 4: Intra-pair matching, each TMDS pair (i.e. D+, D-)

Note 5: These measurements performed with no external capacitor on V<sub>p</sub> (V<sub>p</sub> floating)

Note 6: These static measurements do not include AC activity on controlled I/O lines.

Note 7: This measurement does not include supply current for the 120µA current source on the CEC pin.

## Performance Information

Typical Filter Performance ( $T_A=25^\circ\text{C}$ , DC Bias=0V, 50 Ohm Environment)

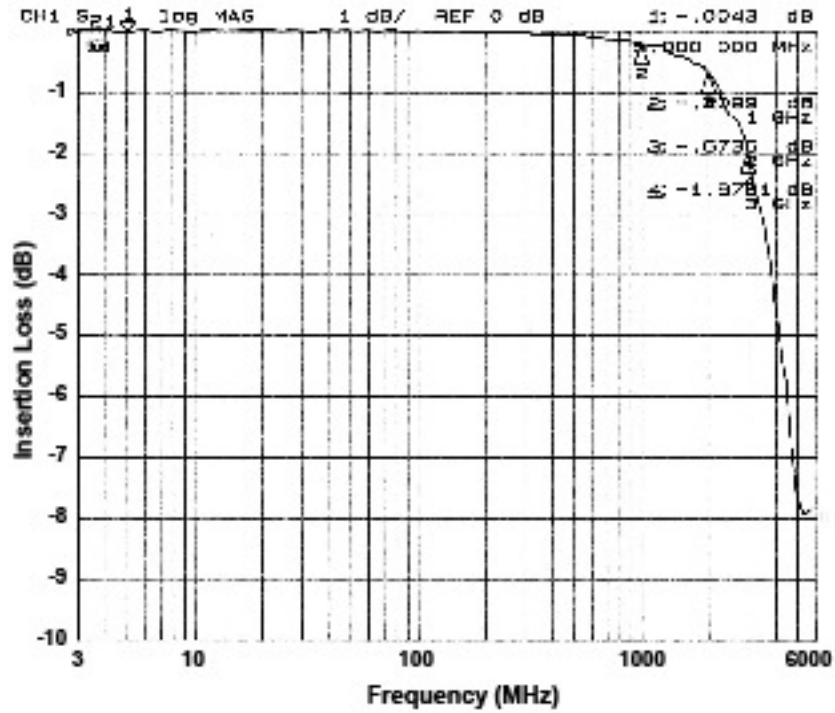

Figure 8. Insertion Loss vs. Frequency (TMD5\_D1- to GND)

## Application Information

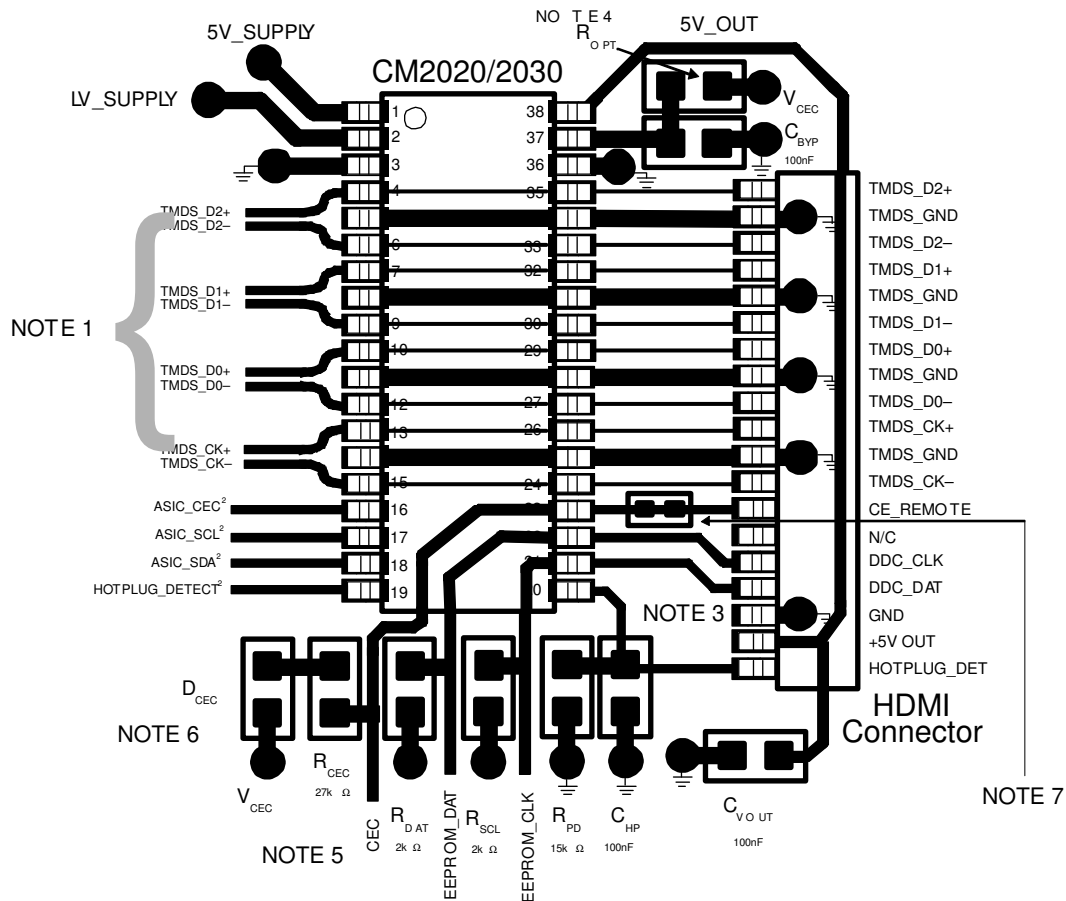

Figure 9. Typical Application for CM2030

### LAYOUT NOTES

1. Differential TMDS Pairs should be designed as normal 100Ω HDMI Microstrip. Single Ended (decoupled) TMDS traces underneath MediaGuard™, and traces between MediaGuard™ and Connector should be tuned to match chip/connector IBIS parasitics.

<sup>2</sup> Level Shifter signals should be biased with a weak pullup to the desired local LV\_SUPPLY. If the local ASIC includes sufficient pullups to register a logic high, then external pullups may not be needed.

<sup>3</sup> Place MediaGuard™ as close to the connector as possible, and as with any controlled impedance line always avoid placing any silk-screen printing over TMDS traces.

<sup>4</sup> CM2020/CM2030 footprint compatibility - For the CM2030, Pin 37 becomes the V<sub>CEC</sub> power supply pin for the slew-rate limiting circuitry. This can be supplied by a 0W jumper to V<sub>CEC</sub> which should be depopulated to utilize the CM2020. The 100nF C<sub>BYT</sub> is recommended for all applications.

<sup>5</sup> CEC pullup isolation. The 27k R<sub>CEC</sub> and a Schottky D<sub>CEC</sub> provide the necessary isolation for the CEC pullup.

Note: *This circuitry is used only in the CM2020.* Depopulate the components for CM2030 applications in a CM2020/ CM2030 dual footprint layout.

<sup>6</sup> Footprint compatibility - The CM2030 has (built-in) internal backdrive protection.

The CM2020 does not have internal backdrive protection and requires the external  $R_{CEC}$  and  $D_{CEC}$  components.

<sup>7</sup> (For CM2030) If CEC firmware *is not* implemented, *do not* populate with 0  $\Omega$  resistor. If CEC firmware is implemented, then populate with 0  $\Omega$  resistor.

(For CM2020) Populate with 0  $\Omega$  resistor in either case.

## Application Information (cont'd)

### Design Considerations

#### 1. 5V out (pin 38)

Maximum overcurrent protection output drop at 55mA on 5V\_OUT is 100mV. To meet HDMI output requirements of 4.8-5.3V, an input of greater than 4.9V should be used (i.e. 5.1V  $\pm$ 4%)

#### 2. DUT On vs. DUT Off

Many HDMI CTS tests require a power off condition on the System Under Test. Many discrete ESD diode configurations can be forward biased when their VDD rail is lower than the I/O pin bias, thereby exhibiting extremely high apparent capacitance measurements, for example. The *MediaGuard*<sup>™</sup> backdrive isolation circuitry limits this current to less than 5mA, and will help ensure HDMI compliance.

**Please review all of the current HDMI design guidelines available at:**

<http://www.calmicro.com/applications/customer/downloads/current-cmd-mediaguard-design-guidelines.zip>

# CM2030

## Mechanical Details

### TSSOP-38 Mechanical Specifications

CM2030 devices are supplied in 38-pin TSSOP packages. Dimensions are presented below.

PACKAGE DIMENSIONS				
	TSSOP			
	MO-153 (Variation BD-1)			
	38			
	—	1.20	—	0.047
	0.05	0.15	0.002	0.006
	0.17	0.27	0.007	0.011
	0.09	0.20	0.004	0.008
	9.60	9.80	0.378	0.386
	6.40 BSC		0.252 BSC	
	4.30	4.50	0.169	0.177
	0.50 BSC		0.020 BSC	
	0.45	0.75	0.018	0.030
	2500 pieces			

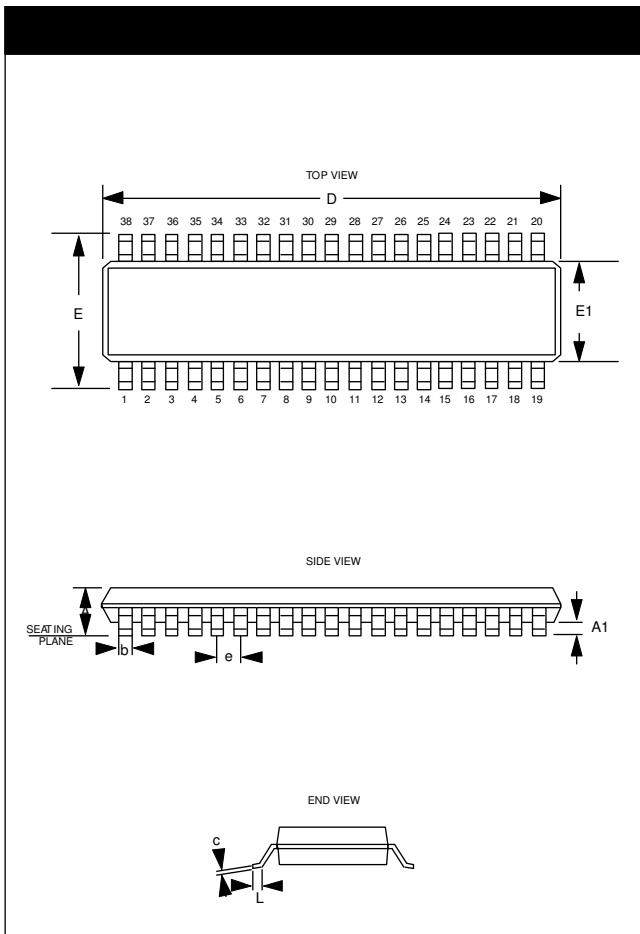

Package Dimensions for TSSOP-38



# CM2030

## Tape and Reel Specifications

PART NUMBER	PACKAGE SIZE (mm)	POCKET SIZE (mm) $B_0 \times A_0 \times K_0$	TAPE WIDTH W	REEL DIAMETER	QTY PER REEL	$P_0$	$P_1$
CM2030	9.70 X 6.40 X 1.20	10.20 X 6.90 X 1.80	16mm	330mm (13")	2500	4mm	12mm

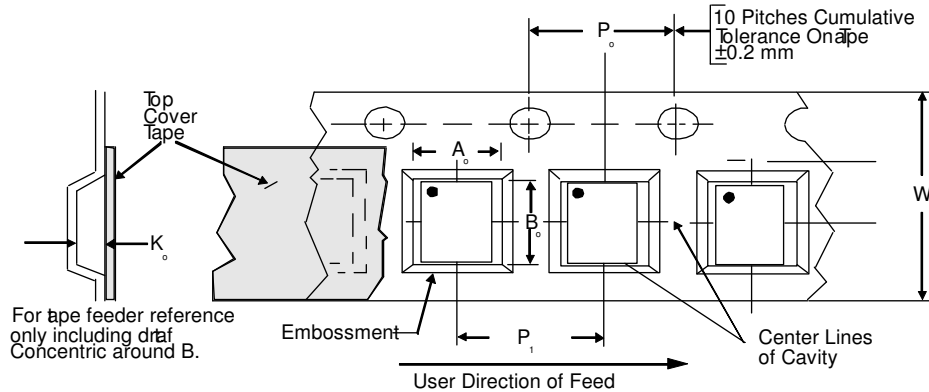

ON Semiconductor and  are registered trademarks of Semiconductor Components Industries, LLC (SCILLC). SCILLC reserves the right to make changes without further notice to any products herein. SCILLC makes no warranty, representation or guarantee regarding the suitability of its products for any particular purpose, nor does SCILLC assume any liability arising out of the application or use of any product or circuit, and specifically disclaims any and all liability, including without limitation special, consequential or incidental damages. "Typical" parameters which may be provided in SCILLC data sheets and/or specifications can and do vary in different applications and actual performance may vary over time. All operating parameters, including "Typicals" must be validated for each customer application by customer's technical experts. SCILLC does not convey any license under its patent rights nor the rights of others. SCILLC products are not designed, intended, or authorized for use as components in systems intended for surgical implant into the body, or other applications intended to support or sustain life, or for any other application in which the failure of the SCILLC product could create a situation where personal injury or death may occur. Should Buyer purchase or use SCILLC products for any such unintended or unauthorized application, Buyer shall indemnify and hold SCILLC and its officers, employees, subsidiaries, affiliates, and distributors harmless against all claims, costs, damages, and expenses, and reasonable attorney fees arising out of, directly or indirectly, any claim of personal injury or death associated with such unintended or unauthorized use, even if such claim alleges that SCILLC was negligent regarding the design or manufacture of the part. SCILLC is an Equal Opportunity/Affirmative Action Employer. This literature is subject to all applicable copyright laws and is not for resale in any manner.

### PUBLICATION ORDERING INFORMATION

**LITERATURE FULFILLMENT:**  
Literature Distribution Center for ON Semiconductor  
P.O. Box 5163, Denver, Colorado 80217 USA  
Phone: 303-675-2175 or 800-344-3860 Toll Free USA/Canada  
Fax: 303-675-2176 or 800-344-3867 Toll Free USA/Canada  
Email: [orderlit@onsemi.com](mailto:orderlit@onsemi.com)

**N. American Technical Support:** 800-282-9855  
Toll Free USA/Canada  
**Europe, Middle East and Africa Technical Support:**  
Phone: 421 33 790 2910  
**Japan Customer Focus Center**  
Phone: 81-3-5773-3850

ON Semiconductor Website: [www.onsemi.com](http://www.onsemi.com)

Order Literature: <http://www.onsemi.com/orderlit>

For additional information, please contact your local Sales Representative