

HOW TO ORDER:

EXAMPLE: 257 - 012 - 2 -14S - 5 P W M

PRODUCT SERIES _____

BASIC NO _____

2 = PLUG ASSEMBLY _____

SHELL SIZE, TABLE I _____

INSERT ARRANGEMENT DASH NO _____

CONTACT STYLE: _____

 P = PIN

 S = SOCKET

ALTERNATE INSERT POSITION, OMIT FOR NORMAL _____

M = MOLDING ADAPTER _____

P = POTTING ADAPTER _____
(OMIT FOR NONE)

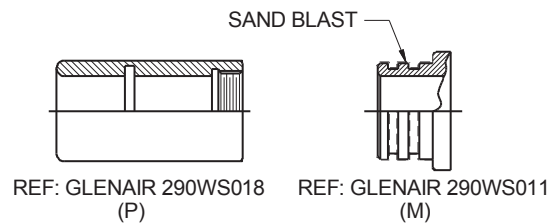
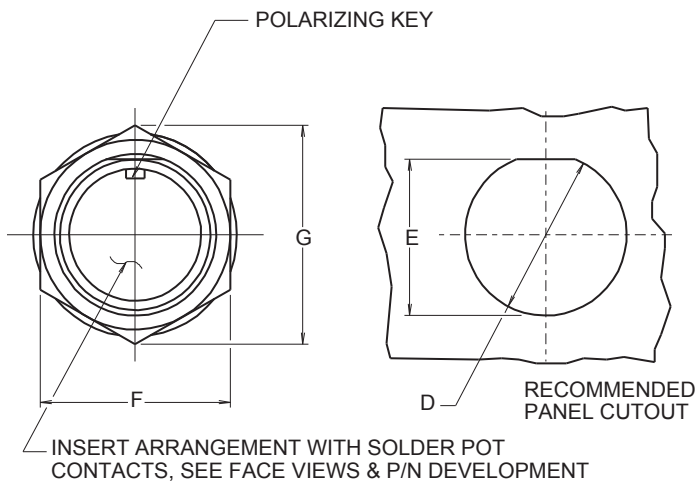
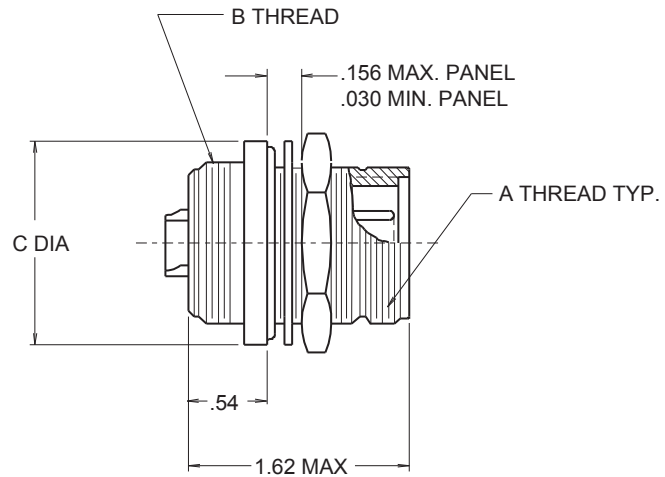

TABLE I: CONNECTOR DIMENSIONS

SHELL SIZE	A THREAD CLASS 2A	B THREAD CLASS 2A	C MAX	D +.010 - .000 (+0.3 - 0)	E +.010 - .000 (+0.3 - 0)	F MAX	G MAX
10SL	5/8 -24 UNEF	5/8 -24 UNEF	1.03 (26.2)	.635 (16.1)	.585 (14.9)	.875 (22.2)	.94 (23.9)
12	3/4 -20 UNEF	3/4 -20 UNEF	1.16 (29.5)	.760 (19.3)	.710 (18.0)	1.000 (25.4)	1.09 (27.7)
14S	7/8 -20 UNEF	7/8 -20 UNEF	1.28 (32.5)	.885 (22.5)	.835 (21.2)	1.125 (28.6)	1.25 (31.8)
16S	1 -20 UNEF	1 -20 UNEF	1.42 (36.1)	1.010 (25.7)	.960 (24.4)	1.250 (31.8)	1.39 (35.3)
18	1 1/8 -18 UNEF	1 1/8 -16 UN	1.66 (42.2)	1.135 (28.8)	1.085 (27.6)	1.500 (38.1)	1.69 (42.9)
20	1 1/4 -18 UNEF	1 1/4 -16 UN	1.78 (45.2)	1.260 (32.0)	1.210 (30.7)	1.625 (41.3)	1.82 (46.2)
24	1 1/2 -18 UNEF	1 1/2 -16 UN	2.03 (51.6)	1.510 (38.4)	1.460 (37.1)	1.875 (47.6)	2.12 (53.8)
28	1 3/4 -18 UNEF	1 3/4 -18 UN	2.28 (57.9)	1.760 (44.7)	1.710 (43.4)	2.125 (54.0)	2.42 (61.5)

257-012
Environment Resistant Plug
MIL-DTL-5015 Type
Mates to Mil-C-5015 (MS3106) Type Plug Connector



MIL-DTL-5015

INSERT ARRANGEMENTS
FACE VIEW OF PIN INSERT SHOWN

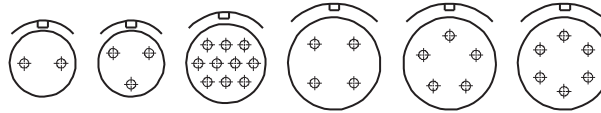

INSERT ARRANGEMENT:	10SL-4	10SL-3	12-10	14S-2	14S-5	14S-6
CONTACT SIZE & QUANTITY:	2 - #16	3 - #16	10 - #20	4 - #16	5 - #16	6 - #16
MS SERVICE RATING:	A	A	INST	INST	INST	INST
ALTERNATE POSITION:	N/A	N/A	N/A	X & Y	X	N/A

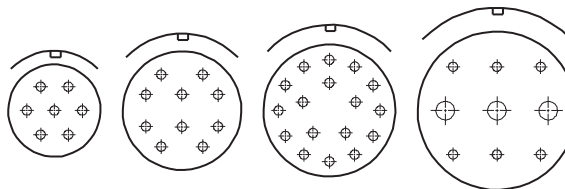

INSERT ARRANGEMENT:	16S-1	18-1	20-29	24-11
CONTACT SIZE & QUANTITY:	7 - #16	10 - #16	17 - #16	6 - #12, 3 - #8
MS SERVICE RATING:	A	4A 6 INST	A	A
ALTERNATE POSITION:	W & Z	W,X,Y & Z	W & Z	W,X,Y & Z

NOTES:

1. ASSEMBLY IDENTIFIED WITH MANUFACTURER'S NAME AND P/N, SPACE PERMITTING.
 2. GLENAIR 257-012 CONNECTOR FEATURES:
 - A. SHELL, ADAPTER: AL ALLOY/HARD COAT
 - B. INSULATOR, O-RING, GROMMET: NITRILE/NEOPRENE
 - C. CONTACTS: GOLD PLATED COPPER ALLOY WITH SOLDER POTS
 - D. CONTACT CURRENT RATING: #20-5 AMPS, #16-10 AMPS, #12-17 AMPS, #8-35 AMPS
 - E. RATED OPERATING VOLTAGE: SERVICE RATING INST - 250 VDC
SERVICE RATING A - 700 VDC
 - F. DIELECTRIC W/STANDING VOLTAGE (HI-POT): SERVICE RATING INST - 1000 VRMS
- A VRMS
 - G. INSULATION RESISTANCE: 5000 MEGOHMS MINIMUM AT 500 VDC AND +25°C
 - H. TEMPERATURE RANGE: -55°C TO +125°C
 3. ELECTRICAL SAFETY LIMITS MUST BE ESTABLISHED BY THE USER.
PEAK VOLTAGES, SWITCHING SURGES, TRANSIENTS, ETC., SHOULD BE
- ⚠️ MATES TO MIL-C-5015 (MS3106) TYPE PLUG CONNECTORS.
USED TO DETERMINE THE SAFETY OF THE APPLICATION.