



# TAI-SAW TECHNOLOGY CO., LTD.

No. 3, Industrial 2nd Rd., Ping-Chen Industrial District,  
Taoyuan, 324, Taiwan, R.O.C.

TEL: 886-3-4690038 FAX: 886-3-4697532

E-mail: [tstsales@mail.taisaw.com](mailto:tstsales@mail.taisaw.com) Web: [www.taisaw.com](http://www.taisaw.com)

## Approval Sheet For Product Specification

Issued Date:

Product Name: SAW Resonator 403.966 MHz SMD 5X5 mm

TST Parts No.: TC0243A

Customer Parts No.: \_\_\_\_\_

Company: _____
Division: _____
Approved by : _____
Date: _____

Checked by: Vincent Liu

Approval by: Francis Chen

Date: 2004/02/06



# TAI-SAW TECHNOLOGY CO., LTD.

No. 3, Industrial 2nd Rd., Ping-Chen Industrial District,  
Taoyuan, 324, Taiwan, R.O.C.

TEL: 886-3-4690038 FAX: 886-3-4697532

E-mail: [tstsales@mail.taisaw.com](mailto:tstsales@mail.taisaw.com) Web: [www.taisaw.com](http://www.taisaw.com)

## SAW Resonator 403.966 MHz

MODEL NO.: TC0243A

REV. NO.:2

### A. FEATURES:

1. 1-Port Resonator.

### B. MAXIMUM RATING:

1. Input Power Level: 0 dBm

2. DC voltage: 12 V

3. Operating Temperature: -40°C to +85°C

4. Storage Temperature: -40°C to +85°C

### C. ELECTRICAL CHARACTERISTICS:

Reference Temperature  $T_A=25^\circ\text{C}$

Characteristic	Units	Minimum	Typical	Maximum
Center frequency <b>F<sub>c</sub></b>	<b>MHz</b>	403.891	403.966	404.041
Insertion Loss <b>IL</b>	<b>dB</b>	-	0.8	2.0
Unloaded Quality factor, <b>Q<sub>U</sub></b>		-	14000	-
Ageing of <b>f<sub>c</sub></b>	<b>ppm/yr</b>	-	-	±10
Motional capacitance <b>C1</b>	<b>fF</b>	-	2.15	-
Motional inductance <b>L1</b>	<b>μH</b>	-	72.2	-
Motional resistance <b>R1</b>	<b>Ohm</b>	-	12.95	-
Parallel capacitance <b>C<sub>o</sub></b>	<b>pF</b>	-	3.65	-
Frequency Temperature coefficient ( <b>TC<sub>f</sub></b> )	<b>ppm/c* 2</b>	-	0.032	-
Turnover <b>T<sub>o</sub></b>	<b>deg.C</b>	10	25	40
Package size		SMD 5X5X1.4mm		

Temperature dependence of  $f_c$ :  $f_c(T_A)=f_c(T_O)(1+TC_f(T_A-T_O)^2)$

### D. OUTLINE DRAWING:

RoHS Compliant  
Lead free  
Lead-free soldering

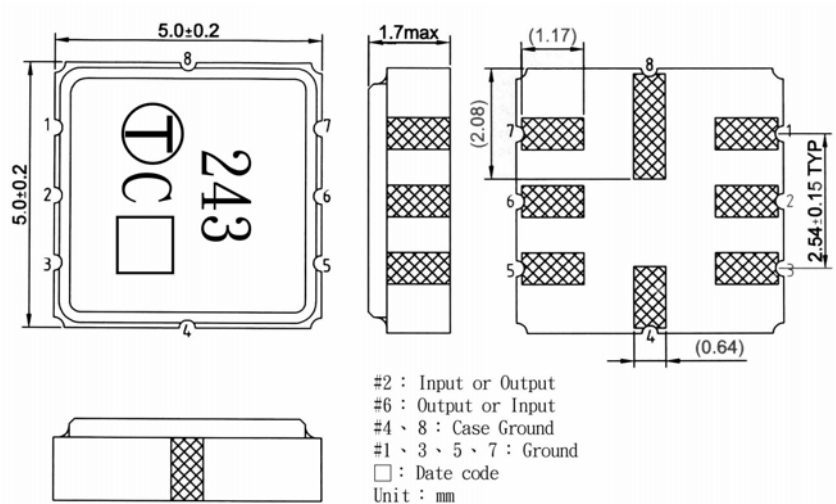

**E. EQUIVALENT CIRCUIT:**

One-Port Resonator:

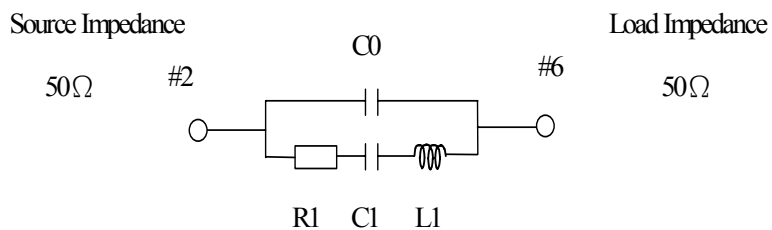

**F. FREQUENCY CHARACTERISTICS:**

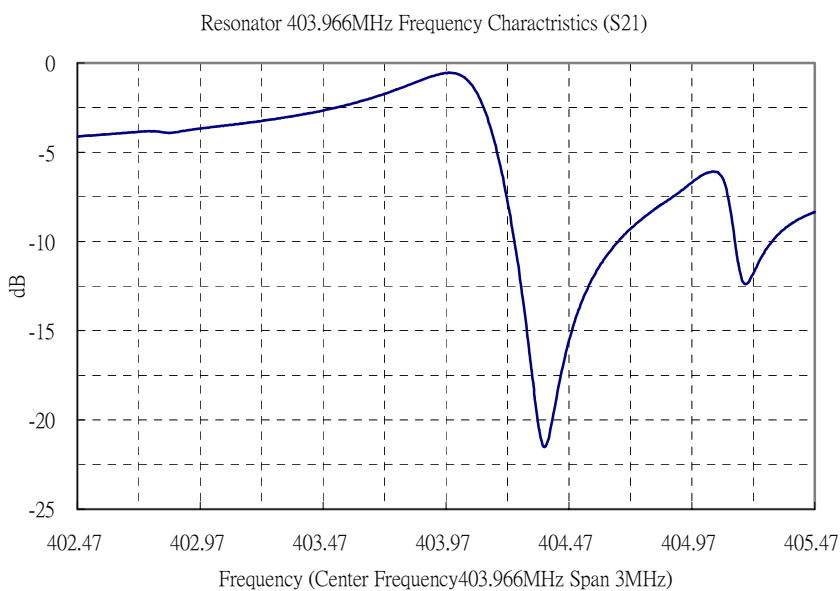

**G. TEST CIRCUIT:**

Network analyzer

From 50Ω  
Network  
Analyzer

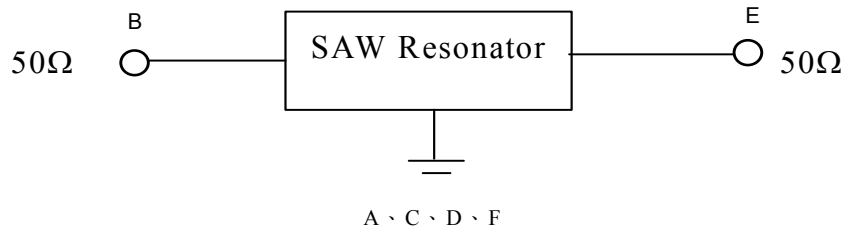

To 50Ω  
Network  
Analyzer

#### H. PACKING:

##### 1. REEL DIMENSION

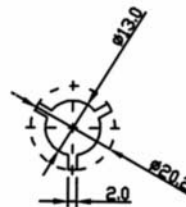
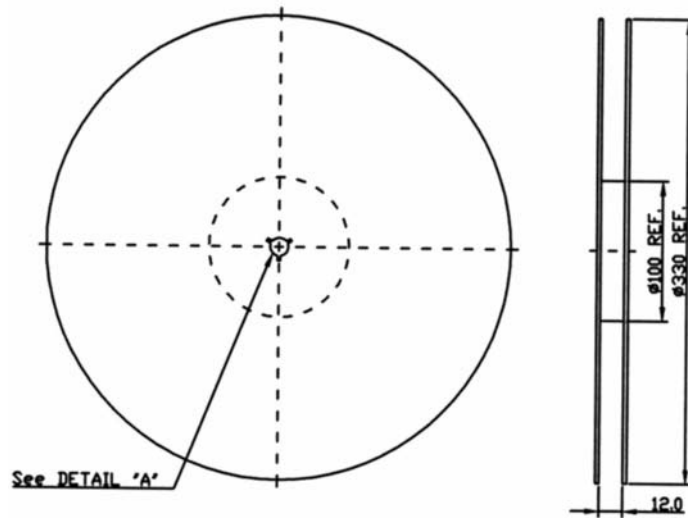

##### 2. TAPE DIMENSION

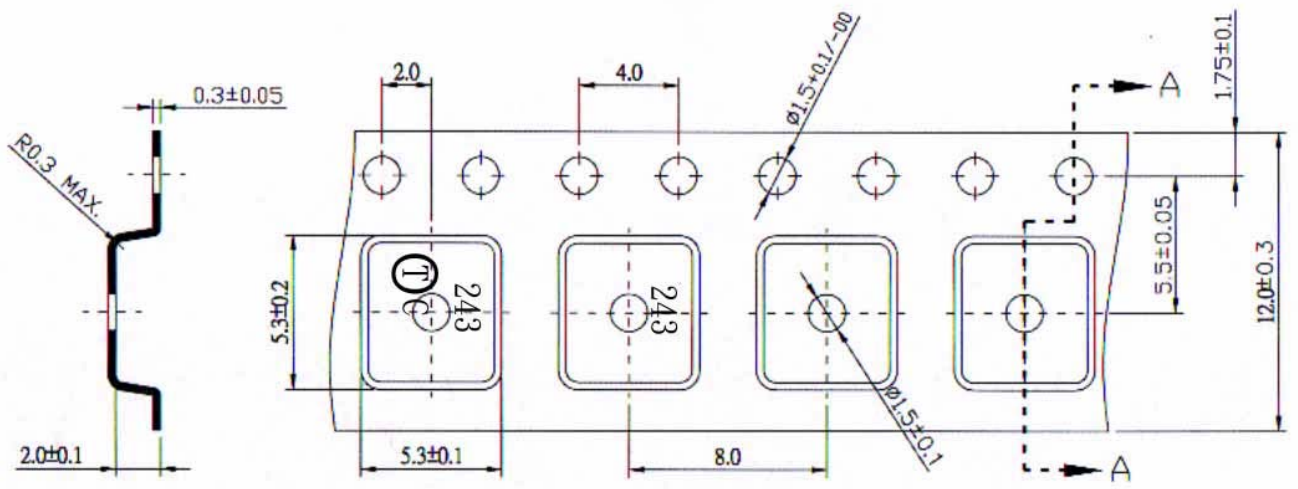

Section A-A