

PLEASE CHECK WWW.MOLEX.COM FOR LATEST PART INFORMATION

Part Number: [0002061101](#)
Status: **Active**
Overview: [standard_062](#)
Description: 1.57mm (.062") Diameter, Standard .062" Pin and Socket Crimp Terminal, Female, with Tin (Sn) Plated Brass Contact, 18-24 AWG, Reel

Documents:

[Drawing \(PDF\)](#) [RoHS Certificate of Compliance \(PDF\)](#)

General

Product Family	Crimp Terminals
Series	1561
Crimp Quality Equipment	Yes
Overview	standard_062
Product Name	Standard .062"

Physical

Gender	Female
Material - Metal	Brass
Material - Plating Mating	Tin
Material - Plating Termination	Tin
Packaging Type	Reel
Plating min: Mating (µin)	20
Plating min: Mating (µm)	0.50
Plating min: Termination (µin)	20
Plating min: Termination (µm)	0.50
Termination Interface: Style	Crimp or Compression
Wire Insulation Diameter	1.52-3.05mm (.060-.120")
Wire Size AWG	18, 20, 22, 24
Wire Size mm ²	N/A

Material Info

Old Part Number	1561-(P901)
-----------------	-------------

Reference - Drawing Numbers

Sales Drawing	SD-1561-*
---------------	-----------

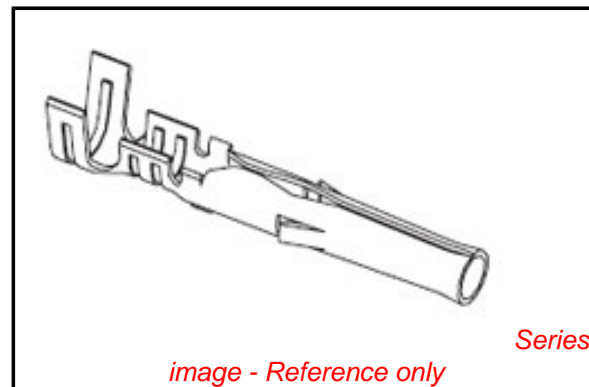

image - Reference only

EU RoHS

**ELV and RoHS
Compliant**

REACH SVHC

Contains SVHC: No

Halogen-Free

Status

Halogen-Free

China RoHS



**Need more information on product
environmental compliance?**

Email productcompliance@molex.com
 For a multiple part number RoHS Certificate of Compliance, [click here](#)

Please visit the [Contact Us](#) section for any non-product compliance questions.

Search Parts in this Series

[1561Series](#)

Application Tooling | [FAQ](#)

Tooling specifications and manuals are found by selecting the products below. Crimp Height Specifications are then contained in the Application Tooling Specification document.

Global

Description	Product #
Mini-Mac™ Applicator	0638914000
Hand Crimp Tool for Standard .062" Pin and Socket Crimp Terminals, 18-24 AWG	0638191300
Manual Extraction Tool	0011030002
Terminator Die	0011402004
Hand Crimper - DISTRIBUTION ONLY	0638111000

Japan

Description

Product #

Hand Insertion Tool 0011020001

This document was generated on 05/17/2010

PLEASE CHECK WWW.MOLEX.COM FOR LATEST PART INFORMATION

PART NO.	ENG. NO.
02-06-1101	1561-(P901)
02-06-1103	1561-(P901)L
02-06-5101	1561-(P561)
02-06-5102	1561-(P561)L
02-06-5108	1561-(P228)
02-06-5109	1561-(P228)L
02-06-5100	1561-(P550)
02-06-5103	1561-(P550)L
02-06-5105	1561-(P591)
02-06-5104	1561-(P591)L
02-06-1118	1561-1(P901)
NOT TOOLED	1561-1(P901)L

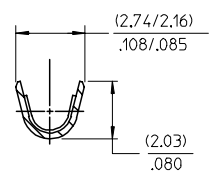
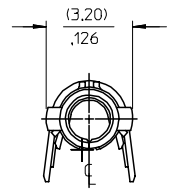
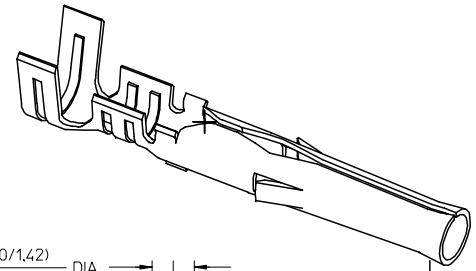

SECT. "B-B"
SCALE:10X

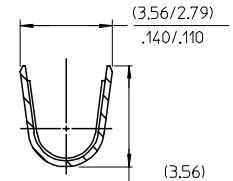

SECT. "C-C"
SCALE:10X

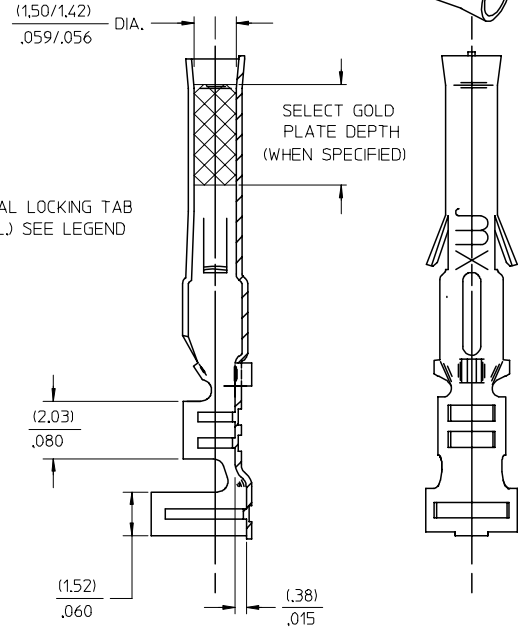
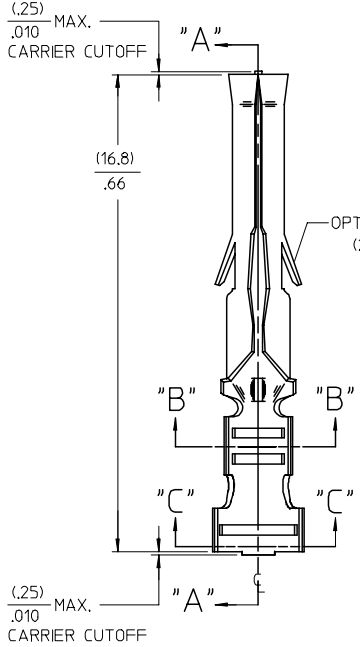

SECT. "A-A"

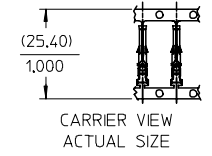

CARRIER VIEW
ACTUAL SIZE

LEGEND

1561-*(****)*
 BLANK=WITH LOCKING TABS
 1=WITHOUT LOCKING TABS
 P=PREPLATE
 BLANK=POSTPLATE
 FORM
 BLANK=CHAIN
 L=LOOSE
 FINISH CODE

- NOTES:
- MATERIAL: BRASS
 - FINISH:
 - 901 HOT TIN DIP (.00051)/.000020 MIN.
 - 228 SELECT GOLD PLATE (.00075)/.000030 MIN. IN CONTACT AREA, SELECT TIN, (.00250)/.000100 MIN. IN CRIMP AREA OVER (.00125)/.000050 MIN. NICKEL OVERALL.
 - 561 SELECT GOLD PLATE (.00076)/.000030 MIN. IN CONTACT AREA, OVER (.00127)/.000050 MIN. NICKEL OVERALL.
 - 591 SELECT GOLD PLATE (.00175)/.000050 MIN. IN CONTACT AREA, OVER (.00127)/.000050 MIN. NICKEL OVERALL WITH (.000025)/.000010 MAX. GOLD FLASH OVERALL.
 - 550 SELECT GOLD PLATE (.00038)/.000015 MIN. IN CONTACT AREA, OVER (.00076)/.000030 MIN. NICKEL OVERALL WITH (.000025)/.000010 MAX. GOLD FLASH OVERALL.
 - THE PRIMARY SHIPPING CARTON WILL BE LABELED, "COMPLIANT TO ROHS DIRECTIVE 2004/95/EC AND ANNEX II OF DIRECTIVE 2000/53/EC", AND CARTONS WITHOUT THIS LABEL MAY CONTAIN PRODUCT WITH TIN-LEAD."
 - PRODUCT SPECIFICATION: PS-02-06.
 - PACKAGING INFORMATION: NOT AVAILABLE
 - TERMINAL FOR USE WITH (1.57)/.062 DIA. SERIES HOUSINGS AND WILL ACCEPT 18 THRU 24 AWG WIRE WITH (1.52/3.05)/.060/.120 INSULATION DIA.

AP	REVISED/REDRAWN UCP2004-2257 RHOLTS 05/14/04
A0	REINSTATE 02065105 UCP2003-1827 ELHAG, 03/02/24
AN	OBSOLETE P/N UCR2002-0270 COMERCI 01/9/25
AM1	ADDED ISO VIEW UCR1998-0248 WANG 98-05-21
AM	REV. AND REDRAWN PER ECR 10372 GEP 8-20-87 RW

SEE REVISION BLOCK EC NO: UCP2004-2257 DRW:RHOLTS 2005/03/06 CHKD:FSMITH 2005/03/30 APPR:FSMITH 2005/04/11	QUALITY SYMBOLS	GENERAL TOLERANCES (UNLESS SPECIFIED)	SCALE 6:1	DESIGN UNITS INCH	THIRD ANGLE PROJECTION	REVISE ON CAD ONLY
	DESCRIPTION AP	4 PLACES ± --- ± --- 3 PLACES ± --- ± .005 2 PLACES ± 0.13 ± .010 1 PLACE ± 0.25 ± --- ANGULAR ±1/2°	DIMENSION STYLE IN/MM		TITLE	
			DRAWN BY GEW DATE 1991/02/19		CRIMP TERMINAL, FEMALE .062 DIA. FOR 18-24 AWG WIRE	
			CHECKED BY RW DATE 1991/02/19		MOLEX MOLEX INCORPORATED	
DRAFT WHERE APPLICABLE MUST REMAIN WITHIN DIMENSIONS		APPROVED BY GWF DATE 1991/02/19	MATERIAL NO. SEE CHART	DOCUMENT NO. SD-1561-*	SHEET NO. 1 OF 1	
THIS DRAWING CONTAINS INFORMATION THAT IS PROPRIETARY TO MOLEX INCORPORATED AND SHOULD NOT BE USED WITHOUT WRITTEN PERMISSION						