

**MS85049/95**  
**3/4 Perimeter Nut Plate for**  
**Flange Mount Receptacle Connector**

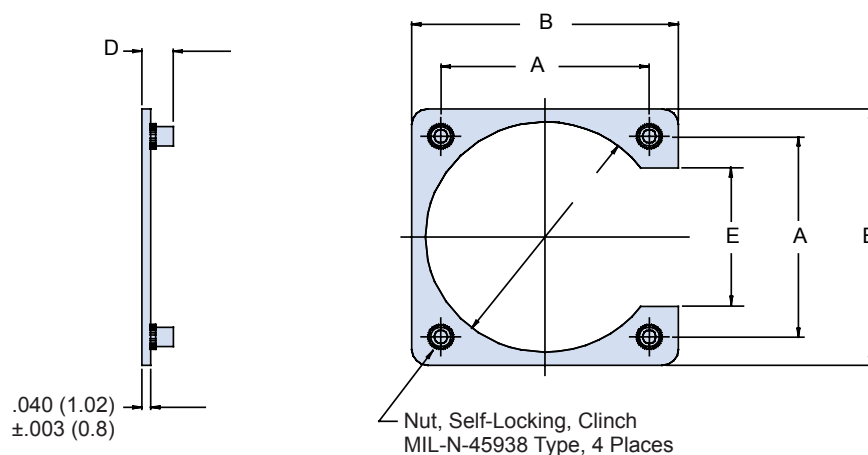

**TABLE I**

Shell Size	Thread UNJC-3B	A ± .003 (0.1)		B ± .015 (0.4)		C + .015 (.4) - .000 (.0)		D ± .030 (0.8)		E ± .031 (0.8)	
3A	4-40	.625	(15.9)	.940	(23.5)	.641	(16.3)	.136	(3.5)	.325	(8.3)
7A	4-40	.719	(18.3)	1.034	(25.9)	.688	(17.5)	.136	(3.5)	.433	(11.0)
8A	4-40	.594	(15.1)	.900	(22.4)	.570	(14.5)	.136	(3.5)	.308	(7.8)
10A	4-40	.719	(18.3)	1.034	(25.9)	.720	(18.3)	.136	(3.5)	.433	(11.0)
10B	6-32	.812	(20.6)	1.202	(33.3)	.749	(19.0)	.136	(3.5)	.433	(11.0)
12A	4-40	.812	(20.6)	1.119	(28.0)	.855	(21.7)	.136	(3.5)	.530	(13.5)
12B	6-32	.938	(23.8)	1.327	(30.1)	.938	(23.8)	.153	(3.9)	.530	(13.5)
14A	4-40	.906	(23.0)	1.213	(30.4)	.984	(25.0)	.136	(3.5)	.624	(15.8)
14B	6-32	1.031	(26.2)	1.421	(35.7)	1.031	(26.2)	.153	(3.9)	.624	(15.8)
16A	4-40	.969	(24.6)	1.285	(32.5)	1.094	(27.8)	.136	(3.5)	.687	(17.4)
16B	6-32	1.125	(28.6)	1.515	(38.1)	1.125	(28.6)	.153	(3.9)	.687	(17.4)
18A	4-40	1.062	(27.0)	1.421	(35.7)	1.220	(31.0)	.136	(3.5)	.780	(19.8)
18B	6-32	1.203	(30.6)	1.593	(40.1)	1.234	(31.3)	.153	(3.9)	.780	(19.8)
19A	4-40	.906	(23.0)	1.207	(30.3)	.953	(24.2)	.136	(3.5)	.620	(15.7)
20A	4-40	1.156	(29.4)	1.550	(39.0)	1.345	(34.2)	.136	(3.5)	.874	(22.2)
20B	6-32	1.297	(32.9)	1.703	(42.9)	1.359	(34.5)	.153	(3.9)	.865	(22.0)
22A	4-40	1.250	(31.8)	1.680	(42.3)	1.478	(37.5)	.136	(3.5)	.968	(24.6)
22B	6-32	1.375	(34.9)	1.753	(44.1)	1.483	(37.7)	.153	(3.9)	.907	(23.0)
24A	4-40	1.500	(38.1)	1.908	(48.0)	1.560	(39.6)	.153	(3.9)	1.000	(25.4)
24B	6-32	1.375	(34.9)	1.800	(45.3)	1.595	(40.5)	.153	(3.9)	1.031	(26.2)
25A	6-32	1.500	(38.1)	1.908	(48.0)	1.658	(42.1)	.153	(3.9)	1.125	(28.6)
27A	4-40	.969	(24.6)	1.270	(31.9)	1.094	(27.8)	.136	(3.5)	.683	(17.3)
28A	6-32	1.562	(39.7)	2.015	(50.8)	1.820	(46.2)	.153	(3.9)	1.125	(28.6)
32A	6-32	1.750	(44.5)	2.327	(58.7)	2.062	(52.4)	.153	(3.9)	1.188	(30.2)
36A	6-32	1.938	(49.2)	2.515	(63.5)	2.312	(58.7)	.153	(3.9)	1.375	(34.9)
37A	4-40	1.187	(30.1)	1.515	(38.1)	1.281	(32.5)	.136	(3.5)	.874	(22.2)
61A	4-40	1.437	(36.5)	1.827	(46.0)	1.594	(40.5)	.136	(3.5)	1.602	(40.7)

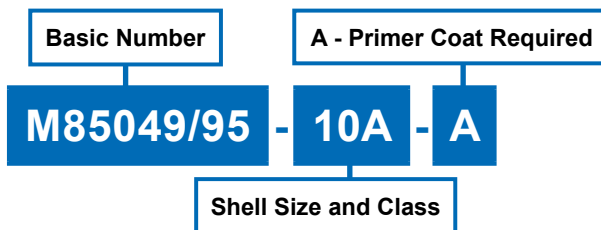