



### Description

Bulletin 700S-CF Safety Control Relays provide mechanically linked, positively guided contacts, which are required in feedback circuits for modern safety applications. The positively guided N.C. auxiliary contacts will not change state if a N.O. contact welds. Consult your local sales office or price list for pricing information.

### Features

- Positively guided/mechanically linked auxiliary contacts
- Front-mounted auxiliary contact:
  - Permanently fixed
  - Protective cover to prevent manual operation
  - Red contact housing for easy identification
  - Incorporates IEC 60947-5-1 “Mechanically Linked” symbol
- AC and DC operating coils
- SUVA third-party certification

### Specifications

#### Conformity to Standards

IEC 60947-5-1

IEC 60947-5-1 Annex L — Special Requirements for Mechanically Linked Contact Elements

EN50011, EN50005, EN50022

UL 508

VDE 0660

CSA 22.2 No. 14

#### Approvals

SUVA Third-Party Certified

CE Certified

CSA Certified

UL Listed (File No. E14840, Guide No. NKCR)

C-Tick not required

#### Your order must include:

- Catalogue number of the relays required, complete with coil suffix.
- Catalogue number of adder decks, timers and accessories required.
- If required, the part number of replacement coils.

**Contactors & Control Relays**  
**Safety Control Relays**  
**700S-CF**

**Product Selection**

**Type CF Control Relays — 8-Pole AC Coil Voltage**



AC-12			AC-15							Connection Diagrams				Contacts		Catalogue Number ❶
$I_{th}$ [A]		40°C	60°C	$I_e$ [A]							Main Contacts	Auxiliary Contacts	NO	NC		
				24/48V	120V	240V	400V	500V	600V	690V						
Main Contacts	20	20	10	10	10	6	2.5	1	1			4	4	700S-CF440⊗C		
												5	3	700S-CF530⊗C		
Adder Deck Contacts	10	6	6	6	5	3	1.6	1	1			6	2	700S-CF620⊗C		

❶ All Catalogue Numbers are factory-stocked.

⊗ **AC Coil Voltage Code**

The Catalogue Number is incomplete. Select a coil voltage code from the table below to complete the Catalogue Number. Example: 120V 60 Hz: Catalogue Number **700S-CF440⊗C** becomes Catalogue Number **700S-CF440DC**.

Voltage	12	24	32	36	42	48	100	100-110	110	120	127	200	200-220	208	208-240	220-230
50 Hz	R	K	V	W	X	Y	KP	-	D	P	S	KG	L	-	-	F
60 Hz	Q	J	-	V	-	X	-	KP	-	D	-	-	KG	H	L	-
50/60 Hz	-	KJ	-	-	-	KY	KP	-	KD	-	-	KG	KL	-	-	KL

Voltage	230	230-240	240	277	347	380	380-400	400	400-415	440	480	500	550	600
50 Hz	-	VA	T	-	-	-	N	-	G	B	-	M	C	-
60 Hz	-	-	A	T	I	E	-	-	-	N	B	-	-	C
50/60 Hz	KF	-	KA	-	-	-	-	KN	-	KB	-	-	-	-

**Product Selection**

**Type CF Control Relays — 8-Pole DC Coil Voltage**



AC-12			AC-15							Connection Diagrams				Contacts		Catalogue Number ①
$I_{th}$ [A]			$I_e$ [A]							Main Contacts	Auxiliary Contacts	NO	NC			
40°C	60°C	24/48V	120V	240V	400V	500V	600V	690V								
Main Contacts	20	20	10	10	10	6	2.5	1	1			4	4	700S-CF440⊗C		
												5	3	700S-CF530⊗C		
Adder Deck Contacts	10	6	6	6	5	3	1.6	1	1			6	2	700S-CF620⊗C		

① All Catalogue Numbers are factory-stocked.

⊗ **DC Coil Voltage Code**

The Catalogue Number is incomplete. Select a coil voltage code from the table below to complete the Catalogue Number. Example: 24V DC: Catalogue Number **700S-CF440⊗C** becomes Catalogue Number **700S-CF440ZJC**.

Voltage	9	12	24	36	48	60	64	72	80	110	115	125	220	230	250
Standard	ZR	ZQ	ZJ	ZW	ZY	ZZ	ZB	ZG	ZE	ZD	ZP	ZS	ZA	ZF	ZT
With diode suppressor	—	—	DJ	—	—	—	—	—	—	—	—	—	—	—	—

# Contactors & Control Relays

## Safety Control Relays

### 100S-C and 700S-CF

#### General





		Catalogue Number 700S-CF	Aux. Contact (Front-mounted)
Contact Ratings — NEMA		A600, P600	A600, Q600
Minimum Contact Rating	17V	10 mA	
	24V	10A	6A
Contact Ratings — IEC	48V	10A	6A
AC-15 (solenoids, contactors) at rated voltage	120V	10A	6A
	240V	10A	5A
	400V	6A	3A
	480V/500V	2.5A	1.6A
	600V	1A	1A
	690V	1A	1A
40°C	$I_{th}$	20A	10A
AC-12 (Non-inductive, or slightly inductive loads, resistance furnaces)	230V	8 kW	
	400V	14 kW	
	690V	24 kW	
60°C	$I_{th}$	20A	6A
	230V	8 kW	
	400V	14 kW	
	690V	24 kW	
Switching DC Loads			
	24V	12A	12A
DC-12	48V	9A	9A
$L_R < 1ms$ , Resistive Loads	110V	3.5A	3.5A
	220V	0.55A	0.55A
	440V	0.2A	0.2A
DC-14	24V	9A	9A
$L_R < 15ms$ , Inductive Loads	48V	5A	5A
with economy resistor in series	110V	2A	2A
	220V	0.4A	0.4A
	440V	0.16A	0.16A
	24V	5A	5A
	48V	3A	3A
DC-13 Switching electromagnets	110V	1.2A	1.2A
	220V	0.6A	0.6A
	440V	0.3A	0.15A

Mechanically Linked Contacts <sup>②</sup>		Yes <sup>①</sup>	
	Location of welded N.O. contacts	State of N.C. Contacts if N.O. contact welds	
		Main	Main
	Main	Open	Open
	Front aux.	Open	Open
	Left side aux.	Open <sup>①</sup>	Open
	Right side aux.	Open <sup>①</sup>	Open

<sup>①</sup> Side-mounted auxiliary contacts provide “mirror contact” performance.

<sup>②</sup> Defined in IEC 60947-5-1 annex L. Positive guidance is a relationship between contacts of opposite types (i.e., N.O. and N.C.)

#### General

		Catalogue Number 700S-CF	Aux. Contact (Front-mntd.)
Mechanical Life	[Mil]	15	15
Electrical Life	AC-15 (240V, 3A) [Mil]	1.5	1.5
Weight	AC Op. Mechanism [g]	390	-
Terminal Cross-Sections			
Terminal Type		2 x A4	2 x A4
Terminal Size per IEC 60947-1			
	Flex. with Wire End Ferrule		
	1 Conductor [mm <sup>2</sup> ]	1...4	0.5...2.5
	2 Conductor [mm <sup>2</sup> ]	1...4	0.75...2.5
	Solid		
	1 Conductor [mm <sup>2</sup> ]	1.5...6	0.5...2.5
	2 Conductor [mm <sup>2</sup> ]	1.5...6	0.75...2.5
Max. Wire Size per UL/CSA	[AWG]	16...10	18...14
Tightening Torque	[lb-in]	8.9...22	8.9...13.3
Tightening Torque	[Nm]	1...2.5	1...1.5

**General (continued)**

		Aux.Contact (Side-mounted)
Contact Ratings — IEC AC-15 (solenoids, contactors) at rated voltage IEC 60947	120V	6
	240V	5
	400V	3
	500V	1.6
AC-12 (Non-inductive, or slightly inductive loads, resistance furnaces), IEC60947	$I_{th}$ 40°C	10A
	$I_{th}$ 60°C	6A
DC-13 (Solenoids and contactors), IEC60947	24V	3A
	48V	1.5A
	110V	0.6A
	220V	0.3A
	440V	0.2A
	[AWG]	18...14
Max. Wire Size per UL/CSA		
Tightening Torque	[lb-in]	8.9...13.3
Tightening Torque	[Nm]	1...1.5

**Control Circuit**

			Catalogue Number 700S-CF
Operating Voltage			
AC 50/60 Hz	Pick-up	[x U <sub>s</sub> ]	0.85...1.1
	Dropout	[x U <sub>s</sub> ]	0.3...0.6
DC <sup>❶</sup>	Pick-up	[x U <sub>s</sub> ]	0.8...1.1
	Dropout	[x U <sub>s</sub> ]	0.1...0.6
Coil Consumption			
AC 50/60 Hz	Inrush	[VA/W]	70/50
	Seal	[VA/W]	8/2.6
DC	Inrush/Seal	[W]	6.5
Operating Times			
AC 50/60 Hz	Pick-up Time	[ms]	15...30
	Dropout Time	[ms]	10...60
DC	Pick-up Time	[ms]	40...70
	Dropout Time	[ms]	7...15

❶ For 9V DC, code ZR, use operating voltage 0.65...1.3 x U<sub>s</sub>.  
 For 24V DC, code ZJ or DJ, use operating voltage 0.7...1.25 x U<sub>s</sub>.

**General (continued)**





	Catalogue Number 700S-CF
Rated Insulation Voltage U <sub>i</sub>	
IEC	690V
UL; CSA	600V
Rated Impulse Strength U <sub>imp</sub>	8 kV
High Test Voltage	
1 minute (per IEC 947-4)	2500V
Rated Voltage U <sub>e</sub>	
AC	115, 230, 400, 500, 690V
DC	24, 48, 110, 220, 440V
Short-Circuit Protection IEC 158-1 Fuse, gG	10A
Rated Frequency	50/60 Hz, DC
Ambient Temperature	
Storage	-55...+80 °C (-67...176 °F)
Operation at nominal current	-25...+60 °C (-13...140 °F)
Conditioned 15% current reduction after AC-1 at > 60°C	-25...+70 °C (-13...158 °F)
Corrosion Resistance	humid-alternating climate, cyclic, per IEC 68-2-30 and DIN 50 016, 56 cycles
Altitude	2000m above mean sea level, per IEC 60947-4
Type of Protection	
IP 2X (IEC 529 and DIN 40050)	in connected state
Finger Protection	safe from touch by fingers and back of hand per VDE 0106, Part 100

## Contactors & Control Relays

# Safety Control Relays

### 100S-C and 700S-CF

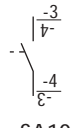
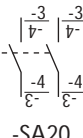
#### Auxiliary Contacts

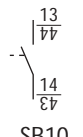
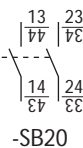

	Description	 NO	 NC	Connection Diagrams	For Use With Catalogue Number	Catalogue Number
	Auxiliary Contact Blocks for Side Mounting <u>without</u> Sequence Terminal Designations ❶ <ul style="list-style-type: none"> <li>• 1- and 2-pole</li> <li>• Two-way numbering for right or left mounting on the contactor</li> <li>• Quick and easy mounting without tools</li> <li>• Electronic-compatible contacts down to 17V, 10mA</li> </ul>	1	0	 -SA10	100S-C all 700S-CF all	100-SA10
		2	0	 -SA20	100S-C AC only 700S-CF AC only	100-SA20
	Auxiliary Contact Blocks for Side Mounting with Sequence Terminal Designations ❶ <ul style="list-style-type: none"> <li>• 1- and 2-pole</li> <li>• Two-way numbering for right or left mounting on the contactor</li> <li>• Quick and easy mounting without tools</li> <li>• Electronic compatible contacts down to 17V, 10mA</li> <li>• L = Late break/Early make</li> </ul>	1	0	 -SB10	100S-C09...C23 700S-CF all❷	100-SB10
		2	0	 -SB20	100S-C09...C23 AC only 700S-CF AC only❷	100-SB20

❶ AC Coils: Max. 2 N.O. auxiliary contacts may be mounted on the side. DC coils: Max. 1 N.O. auxiliary contact may be mounted on the side. No additional N.C. auxiliary contacts may be added to safety contactors and control relays listed in this publication. For additional contact configurations, consult your local Rockwell Automation/Allen-Bradley distributor.



❷ Double Numbering — Left-side mounting only is recommended for Catalogue Number 700S-CF... due to double numbering.

#### Marking Systems

Uniform labelling materials for contactors, motor starting equipment, timing relays and circuit breakers

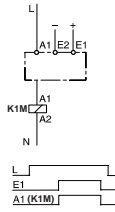

	Description	Package Qty.	Catalogue Number
	Label Sheet <ul style="list-style-type: none"> <li>• Sheet with 105 self-adhesive paper labels, 6 x 17 mm</li> </ul>	10	100-FMS
	Marking Tag Sheet <ul style="list-style-type: none"> <li>• Sheet with 160 perforated paper labels, 6 x 17 mm</li> <li>• To be used with a transparent cover</li> </ul>	10	100-FMP
	Transparent Cover <ul style="list-style-type: none"> <li>• To be used with marking tag sheets</li> </ul>	100	100-FMC
	Marking Tag Adaptors <ul style="list-style-type: none"> <li>• 100 each</li> <li>• To be used with marking tag:</li> </ul>	System V4/V5	100-FMA1
		System Bul. 1492W	100-FMA2

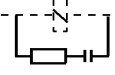
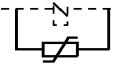
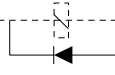
**Control Modules**

	Description		Connection Diagrams	For Use With Catalogue Number	Catalogue Number	
	<b>DC Interface</b> (electronic) <ul style="list-style-type: none"> <li>Interface between the DC control signal (PLC) and the contactor AC operating mechanism</li> <li>Control voltage 18...30V DC (24V DC nominal)</li> <li>For coil voltage of 110... 240V AC</li> <li>Suitable for all 100S-C contactor sizes, 9...85 A</li> <li>Requires no additional surge suppression for the coils</li> <li>Power consumption                             <ul style="list-style-type: none"> <li>- 0.1 W at 18V DC</li> <li>- 0.25 W at 24V DC</li> <li>- 0.5 W at 30V DC</li> </ul> </li> </ul>			100S-C with AC coils 700S-CF with AC coils	<b>100-JE</b>	
	<b>Surge Suppressors</b> For limitation of coil switching transients. <ul style="list-style-type: none"> <li>Plug-in, coil mounted</li> <li>Suitable for all 100S-C contactor sizes, 9...85 A</li> <li>RC, Varistor and Diode Versions</li> </ul>	RC Module AC Operating Mechanism	24...48V, 50/60 Hz 110...280V, 50/60 Hz 380...480V, 50/60 Hz		100S-C with AC coils 700S-CF with AC coils	<b>100-FSC48</b> <b>100-FSC280</b> <b>100-FSC480</b>
		Varistor Module AC/DC Operating Mechanism	12...55V AC/12...77V DC 56...136V AC /78...180V DC 137...277V AC /181...350V DC 278...575V AC		100S-C all 700S-CF all	<b>100-FSV55</b> <b>100-FSV136</b> <b>100-FSV277</b> <b>100-FSV575</b>
		Diode Module DC Operating Mechanism	12...250V DC		100S-C with DC coils 700S-CF with DC coils	<b>100-FSD250</b>

Contactors & Control Relays  
**Safety Control Relays**  
**100-D**



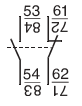
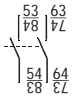
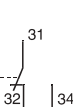

**Auxiliary Contacts**

Description			Connection Diagrams	For Use with Catalogue Number	Catalogue Number
	NO	NC			
 <ul style="list-style-type: none"> <li>Side-mounted</li> <li>With IEC sequence terminal designations</li> </ul>	1	1		100-D Left or right outside mounting	<b>100-DS2-11</b>
	2	0		100-D Left or right outside mounting	<b>100-DS2-20</b>
	1	1		100-D Left or right outside mounting	<b>100-DS2-B11</b>
<ul style="list-style-type: none"> <li>Electronically compatible auxiliary contacts</li> <li>Ideal for use when switching low-power control circuits</li> <li>Contact ratings: AC-1                   250V, 0.1 A AC-15, DC-13       3...125V, 1...100V,</li> </ul>					

**Labeling Material**



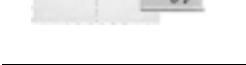

	Uniform labeling materials for contactors, motor protection devices, timing relays, and circuit breakers.
---	---

**Marking Systems (for 100-D95...D860 contactors)**

Description	Package Qty.	Catalogue Number
 <p>Label Sheet</p> <ul style="list-style-type: none"> <li>10 sheets with 105 self-adhesive paper labels each, 6 x 17mm</li> </ul>	10	<b>100-FMS</b>
 <p>Marking Tag Sheet</p> <ul style="list-style-type: none"> <li>10 sheets with 160 perforated paper labels each, 6 x 17mm</li> <li>To be used with a transparent cover</li> </ul>	10	<b>100-FMP</b>
 <p>Transparent Cover</p> <ul style="list-style-type: none"> <li>100 each</li> <li>To be used with marking tag sheets</li> </ul>	100	<b>100-FMC</b>
 <p>Marking Tag Adaptors</p> <ul style="list-style-type: none"> <li>100 each</li> <li>To be used with marking tag:</li> </ul>	System V4/V5	<b>100-FMA1</b>
	System Bul. 1492W	<b>100-FMA2</b>







**Auxiliary Contacts**

	Internal Auxiliary Contacts Catalogue Numbers 100S-C09...100S-C23	Side-Mounted Auxiliary Contacts Catalogue Numbers 100-SA, 100-SB, 100-MC
Current Switching		
AC-12 $I_{th}$ at 40°C [A]	25	10
at 60°C [A]	20	6
AC-15 at Rated Operating Voltage [V]	24 48 120 240 400 415 500 690	24 48 120 240 400 415 500 690
[A]	10 10 10 10 6 5 2.5 1	6 6 6 5 3 2.5 1.6 1
DC-13 at Rated Operating Voltage [V]	24 48 110 220 400	24 48 110 220 400
[A]	5 2 0.7 0.25 0.12	5 2 0.7 0.25 0.12
Continuous Current Rating per UL/CSA		
AC [A]	10A, 600V (NEMA A600)	10A, 600V (NEMA A600)
DC [A]	5A, 600V (NEMA P600)	2.5A, 600V (NEMA Q600)
Short-Circuit Protection gG Fuse Type 2 Coordination [A]	10	10
<b>Rated Impulse Voltage</b> $U_{imp}$ [kV]	8	6
<b>Insulation Voltage</b> (between control and load circuit) per DIN, VDE 0106, Part 101 (NAMUR recommendation) [V]	250	500
<b>Contact reliability</b> per DIN 19240 without contamination, normal industrial atmosphere	17V, 10mA	17V, 10mA
Mechanically Linked Contacts per IEC 60947-5-1 Annex L (SUVA Third-party certified)	Mutually unrestricted between all N.O. and N.C. contacts	100-SA, 100-SB: Mirror output performance per IEC60947-4 Annex F 100-MC: Mutually unrestricted between all N.O. and N.C. contacts
Terminals		
Terminal Type	2 x A4	2 x A4
Wire Size per IEC 60947-1		
 Flexible w/Wire-End Ferrule 1 Conductor [mm <sup>2</sup> ]	1...4	0.5...2.5
2 Conductor [mm <sup>2</sup> ]	1...4	0.75...2.5
 Solid/Stranded Conductor 1 Conductor [mm <sup>2</sup> ]	1.5..6	0.5..2.5
2 Conductor [mm <sup>2</sup> ]	1.5..6	0.75...2.5
Recommended Tightening Torque (min...max) Nm	1.2.5	1...1.5
Wire Size per UL/CSA [AWG]	16...10	18...14
Recommended Tightening Torque (min...max) [lb-in]	8.9..22	8.9...13.3

**Contactors & Control Relays**  
**Safety Control Relays**  
**100-DS2**

**Auxiliary Contacts**

	Side-Mounted Auxiliary Contacts Catalogue Numbers 100-DS2	
	Conventional	Electronically Compatible
Current Switching		
AC-12 $I_{th}$ at 40°C [A]	16	0.1 at 250V
at 60°C [A]	12	
AC-15 at Rated Operating Voltage [V]	230 240 400 415 500 690	
[A]	5.5 5 3 2.5 1.6 1	1... 100mA
DC-13 at Rated Operating Voltage [V]	24 48 110 220 440	at 3... 125V
[A]	5 2 0.7 0.25 0.12	
Continuous Current Rating per UL/CSA		
AC [A]	10A, 600V (NEMA A600)	
DC [A]	2.5A, 600V (NEMA Q600)	
Short-Circuit Protection gG Fuse		
Type 2 Coordination [A]	10	—
<b>Rated Impulse Voltage</b> $U_{imp}$ [kV]	8	
<b>Insulation Voltage</b> (between control and load circuit) per DIN, VDE 0106, Part 101 (NAMUR recommendation) [V]		
<b>Contact reliability</b> per DIN 19240 without contamination, normal industrial atmosphere	17V, 5mA	17V, 1mA
Mechanically Linked Contacts per IEC 60947-5-1 Annex L (SUVA Third-party certified)	Mirror contact performance per IEC 60947-4 Annex F	Mirror contact performance per IEC 60947-4 Annex F
Terminals		
Terminal Type	2 x A4	2 x A4
Wire Size per IEC 60947-1		
 Flexible w/Wire-End Ferrule 1 Conductor [mm <sup>2</sup> ]	1...2.5	1...2.5
2 Conductor [mm <sup>2</sup> ]	1...2.5	1...2.5
 Solid/Stranded Conductor 1 Conductor [mm <sup>2</sup> ]	1...4	1...4
2 Conductor [mm <sup>2</sup> ]	1...4	1...4
Recommended Tightening Torque (min...max) Nm	1.4...2.3	1.4...2.3
Wire Size per UL/CSA [AWG]	16...12	16...12
Recommended Tightening Torque (min...max) [lb-in]	12...20	12...20

**Dimensions—mm (inches)**

Dimensions are not intended for manufacturing purposes.

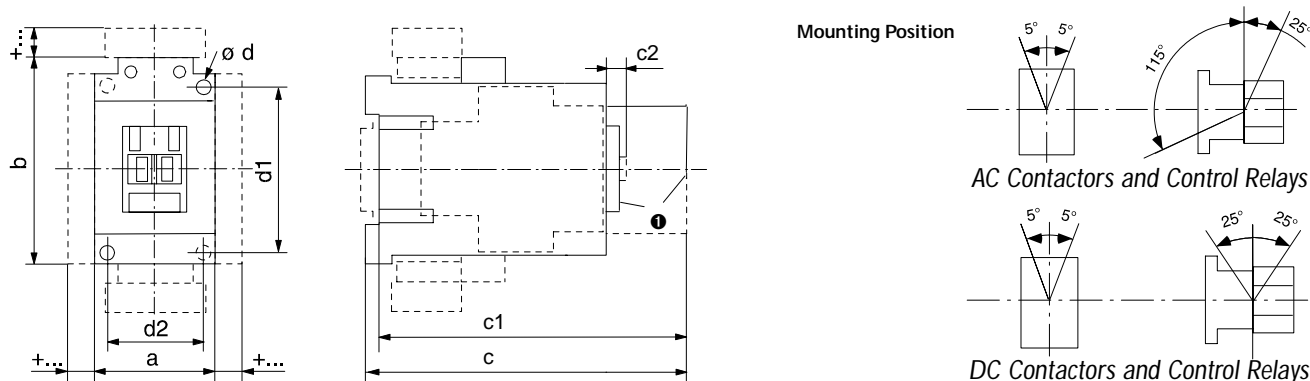

**AC Contactors and Control Relays**

a	b	c	c1	c2	∅d	d1	d2	Catalogue Number
45 (1-25/32)	81 (3-3/16)	119.5 (4-3/4)	114.5 (4-43/64)	6 (1/4)	2 - 4.5 (2 - 3/16)	60 (2-23/64)	35 (1-25/64)	100S-C09...100S-C23, 700S-CF
45 (1-25/32)	81 (3-3/16)	136.5 (5-37/64)	131.6 (5-11/32)	6.5 (17/64)	2 - 4.5 (2 - 3/16)	60 (2-23/64)	35 (1-25/64)	100S-C30, 100S-C37
54 (2-1/8)	81 (3-3/16)	139.5 (5-11/16)	134.6 (5-29/64)	6.5 (17/64)	2 - 4.5 (2 - 3/16)	60 (2-23/64)	45 (1-25/32)	100S-C43
72 (2-53/64)	122 (4-51/64)	156 (6-11/32)	150.5 (6-1/8)	8.5 (21/64)	4 - 5.4 (4 - 7/32)	100 (3-15/16)	55 (2-11/64)	100S-C60...100S-C85

**DC Contactors and Control Relays**

a	b	c	c1	c2	∅d	d1	d2	Catalogue Number
45 (1-25/32)	81 (3-3/16)	145.5 (5-49/64)	140.5 (5-37/64)	6 (1/4)	2 - 4.5 (2 - 3/16)	60 (2-23/64)	35 (1-25/64)	100S-C09Z...100S-C16Z, 700S-CF
45 (1-25/32)	81 (3-3/16)	162.5 (6-7/16)	158 (6-1/4)	6 (1/4)	2 - 4.5 (2 - 3/16)	60 (2-23/64)	35 (1-25/64)	100S-C23Z
45 (1-25/32)	81 (3-3/16)	180.5 (7-5/32)	175.5 (6-61/64)	6.5 (17/64)	2 - 4.5 (2 - 3/16)	60 (2-23/64)	35 (1-25/64)	100S-C30...100S-C37
54 (2-1/8)	81 (3-3/16)	183.5 (7-17/64)	179 (7-3/32)	6.5 (17/64)	2 - 4.5 (2 - 3/16)	60 (2-23/64)	45 (1-25/32)	100S-C43Z
72 (2-53/64)	122 (4-51/64)	156 (6-11/32)	150.5 (6-1/8)	8.5 (21/64)	4 - 5.4 (4 - 7/32)	100 (3-15/16)	55 (2-11/64)	100S-C60D...100S-C85D

**Accessories**

Contactors with	mm	(inches)
Auxiliary contact block for side mounting 1- or 2-pole	a + 9	(a + 23/64)
Electronic Timing Module on coil terminal side	b + 24	(b + 15/16)
Mechanical Interlock on side of contactor	a + 9	(a + 23/64)
Interface Module on coil terminal side	b + 9	(b + 23/64)
Surge Suppressor on coil terminal side	b + 3	(b + 1/8)
Labelling with label sheet	+ 0	(+ 0)
marking tag sheet with clear cover	+ 0	(+ 0)
marking tag adapter for System V4/V5	+ 5.5	(+ 7/32)
marking tag adapter for System Bul. 1492W	+ 5.5	(+ 7/32)

**Contactors & Control Relays**  
**Safety Control Relays**  
**100S-D Contactors and Accessories**

**Dimensions—mm (inches)**

Dimensions are not intended for manufacturing purposes.

**Mounting Position**

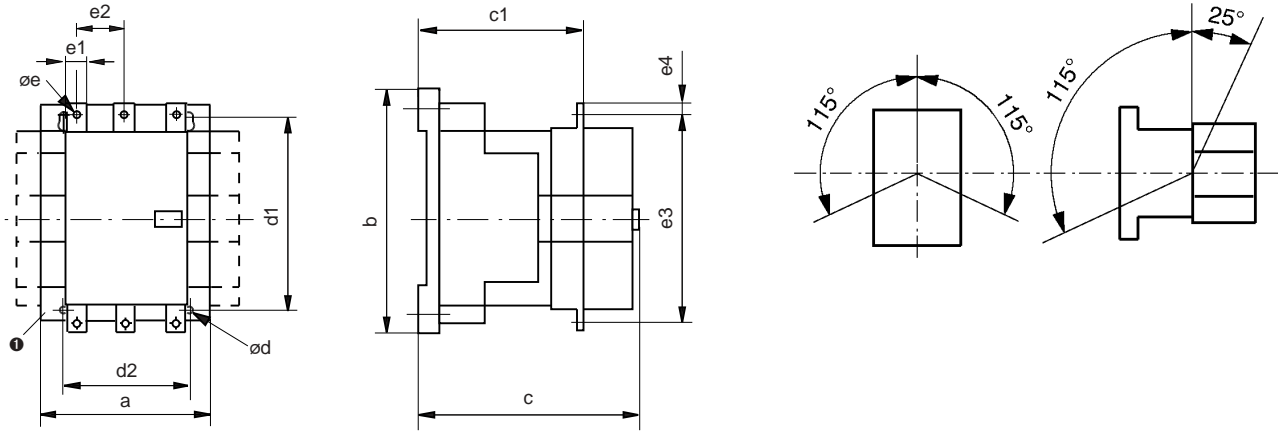

Catalogue Number	a	b	c	c1	$\phi d$	d1	d2	$\phi e$	e1	e2	e3	e4
100S-D95, 100S-D110	120	170	156	110.5	5.2	145	100	M6	16	38.5	147	8
100S-D95-EI...100S-D180-EI, 100S-D140, 100S-D180	120	170	156	110.5	5.2	145	100	M8	20	39	160	10
100S-D210-EI...100S-D420-EI	155	205	180	110.5	6.5	180	130	M10	25	48	193	12.5
100S-D630-EI...100S-D860-EI	255	310	265	110.5	10	230	225	M12	40	70	291	22

Contactor with		[mm]
Auxiliary contact block	100-DS2...	$a + 13.5$ each
Mechanical interlock	100-DM...	$a + a$
Frame terminal block	100-DTB110	$b + 7$ each
	100-DTB180	$b + 7$ each
	100-DTB420	$b + 8.5$ each
Label holder		$c... + 5$

● Convention DC coil contactors will have an additional auxiliary contact block mounted which will add 13.5mm (0.53in) to the "a" dimension on the right hand side.